

- Timber
- Aluminium
- Concrete

MAR 2026

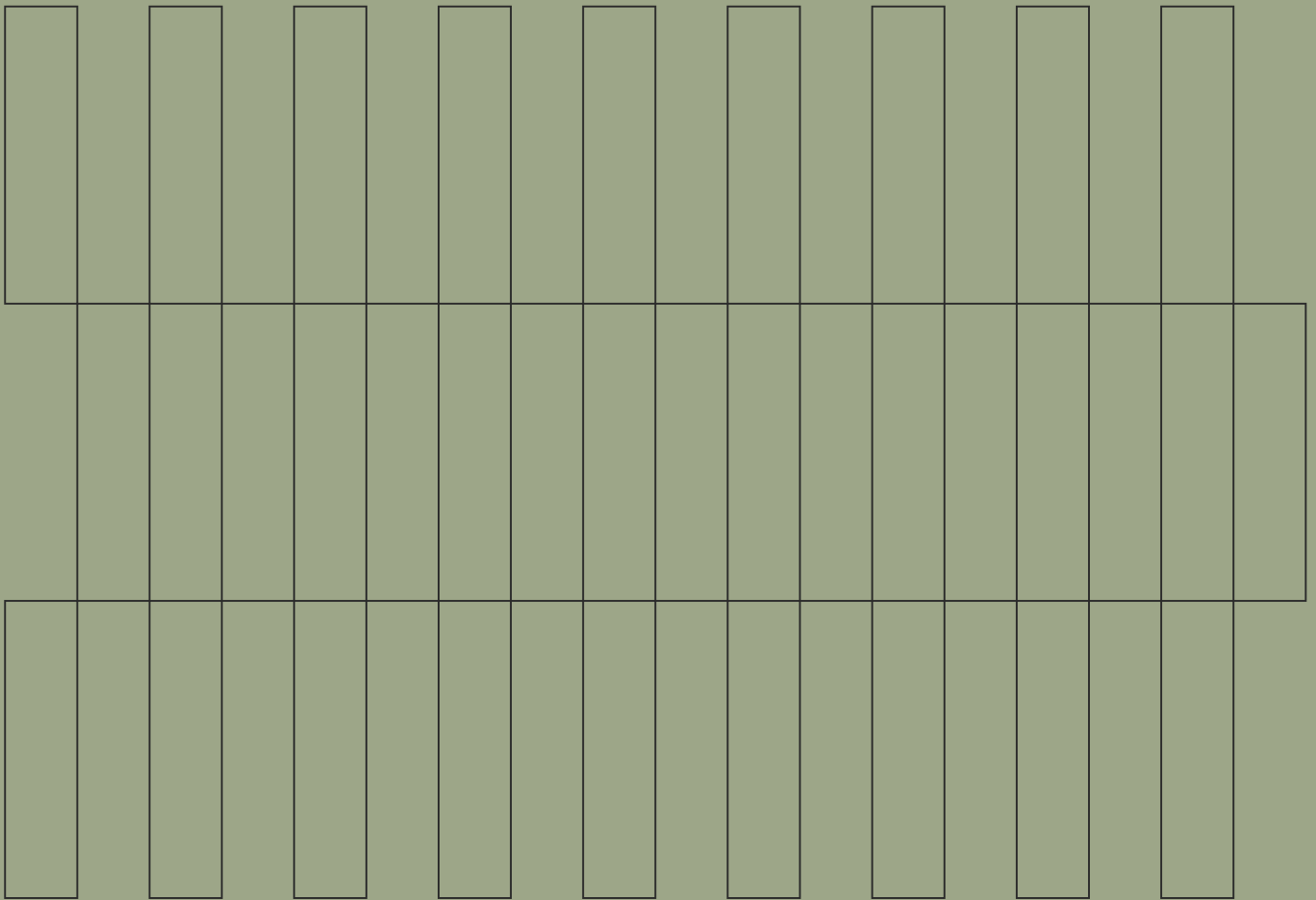

Austratus System

Installation Guide

Product Storage

Upon delivery, materials should be inspected to confirm the correct products have been supplied and that there is no visible damage. Any evident defect, damage, shortage or discrepancy with the description or quotation must be reported to Modinex in writing within seven (7) days of delivery. We recommend checking materials within 48 hours so any issues can be identified promptly.

Once materials have been delivered to site, storage becomes the responsibility of the client or installer. Products should be stored in a dry, protected area, out of weather and away from site traffic or activities that may cause damage. Where possible, materials should be kept flat, supported and clear of the ground until installation.

Interior wall and ceiling quick fix system

Our patented fitting system allows continuous lengths of timber to be simply and easily clipped into a suspended ceiling. It can also be screwed directly onto existing walls and ceilings.

- Complete, off-the-shelf system including hanging rods, clips, rails and selected timber profiles.
- A seamless finish. For added convenience, Austratus also supplies specially-engineered finishing trims and spacers.
- A system that's engineered to stringent quality standards.

Prior to construction, check with your local regulatory agency for special code requirements for your project.

As with any building project, installing Austratus will have the best result when you think through the entire process in advance, familiarising yourself with the materials and their application. Think of how you want the project to look. Please review the following tips before starting work on a Austratus ceiling or wall.

For additional installation support, call Austratus on 1800 156 455.

Safety & Tools

Standard safe practices should, of course, be employed when using any tools during installation. Austratus timber and aluminium profiles can be drilled, sawn, fastened or routed with normal woodworking or aluminium saws and drill bits.

Foundation & Sub-Structure

Austratus is not for use as a component of the foundation or substructure. When constructing the substructure, care must be taken to ensure that supporting rails and clips are level, straight and square as Austratus will conform to the alignment of them.

Refer to Page 4 for cover area calculations

Refer to Page 12 to 15 for fire rating & wind load tables – interior use only (indoor / outdoor environment with closeable space)

Refer to Page 16 for seismic data & installation guide

Parts and Equipment

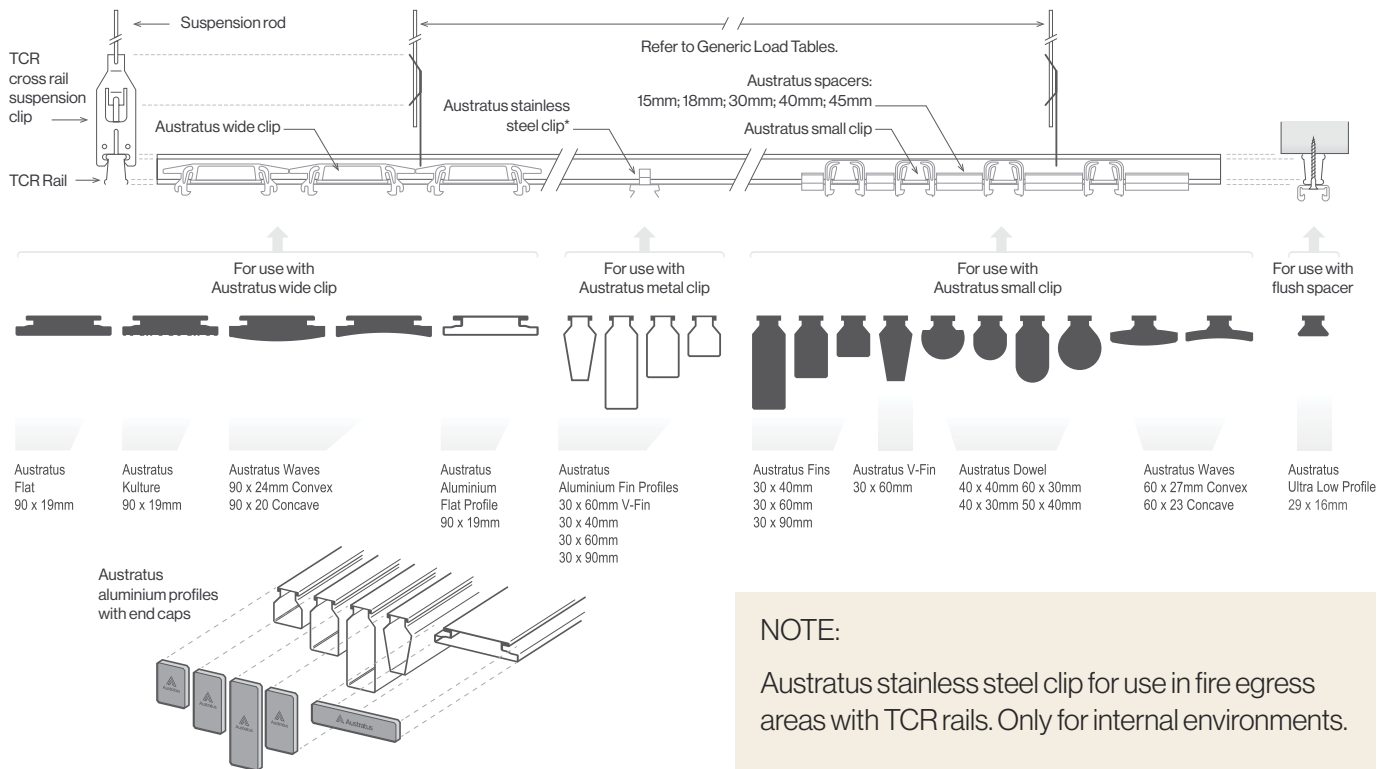

Diagram 1

Colour & Orientation

Austratus timber profiles such as Western Red Cedar and Hemlock contain natural variations in grain and colour. Western Red Cedar

in particular can appear from a dark chocolate or cherry colour to a pale blonde. We recommend that wherever possible you purchase all of the boards required for your project at the same time in order to avoid any possible colour variation that may occur between different batches. To ensure an even look across the wall or ceiling it is advisable to lay out the boards before fixing to allow you to check your colour mix and grain – this also ensures that each board is the same temperature prior to any cutting.

Batten, Spacing & Material Choice

Consider your Austratus material of choice. Choose from our selection of five timbers or aluminium:

- Western Red Cedar
- Hemlock
- Thermally Modified Hemlock
- Blackbutt
- Spotted Gum
- Tasmanian Oak
- Aluminium

Austratus aluminium profiles can be supplied in customised colours to suit larger projects that require a unique look.

Spacing for Austratus battens should be considered in line with the tables in Generic Structural Design Certification. These tables provide confirmation of loading; rail spans between rail clips; and rail spacing for timber species and spacing of your choice.

Generic Structural Design Certification

Basis of certification

- AS/NZS1170.0:2002 Structural Design Actions – General Principles
- AS/NZS1170.1:2002 Structural Design Actions – Permanent, Imposed & Other Actions
- AS/NZS 1664.1:1997 Aluminium Structures – Limit State Design
- AS/NZS 1664.2:1997 Aluminium Structures – Allowable Stress Design
- AS 1720.1:2010 Timber Structures – Design Methods

Reference documentation Drawing Set:

19-15471-S01—S06 REV-B (105 Pages)

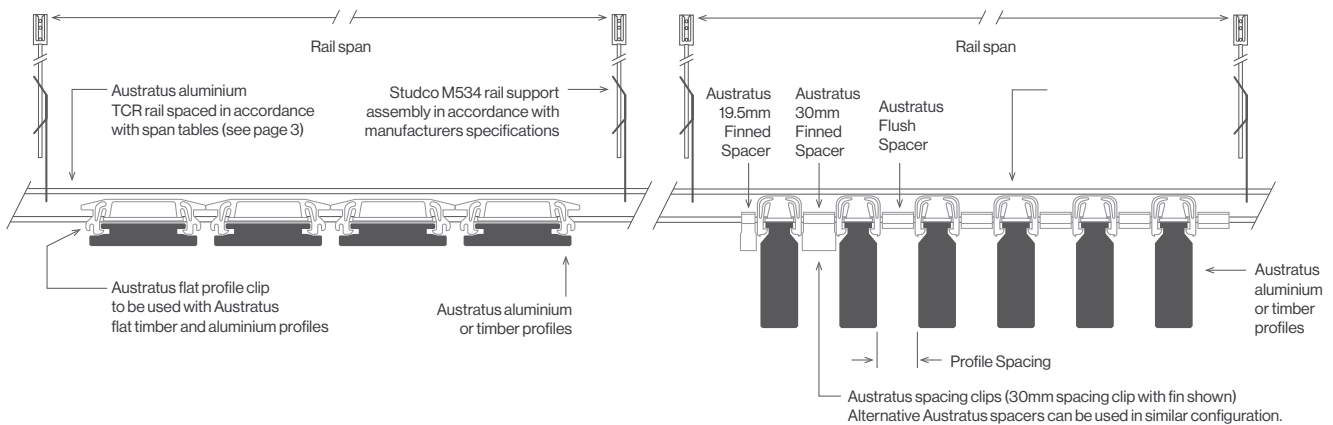

Diagram 2

Diagram 3

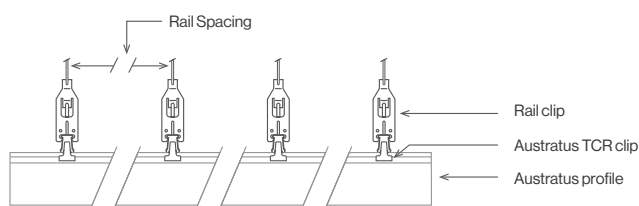

Diagram 4

NOTE:

- Max batten length of 6000m and > 10kg in weight
- Max individual profile length pages 5–9 in the Generic Structural Design Certification

Coverage

Before commencing, confirm that you have the correct tools, service access and product to cover the area specified. The tables below give product codes and rough measures for the coverage required, as well as the number of clips, joiners and TRC rails.

Profile	Spacing (mm)	Lm per m ²	TCR Spacing (mm)	Clips per m ²	Spacers per m ²
Flat Profile					
PR-AUSFLAT-90X18	-	11.2	600	18.7	18.7
PR-AUSFLAT-90X18	18	9.3	600	15.5	15.5
PR-AUSFLAT-90X18	30	8.4	600	14.0	14.0
PR-AUSFLAT-90X18	50	7.2	600	12.0	12.0
Fin Profiles					
PR-AUSFIN-30X40	30	16.7	600	27.9	27.9
PR-AUSFIN-30X40	60	11.2	600	18.7	18.7
PR-AUSFIN-30X40	90	8.4	600	14.0	14.0
PR-AUSFIN-30X60	30	16.7	600	27.9	27.9
PR-AUSFIN-30X60	60	11.2	600	18.7	18.7
PR-AUSFIN-30X60	90	8.4	600	14.0	14.0
PR-AUSFIN-30X90	30	16.7	600	27.9	27.9
PR-AUSFIN-30X90	60	11.2	600	18.7	18.7
PR-AUSFIN-30X90	90	8.4	600	14.0	14.0
V Fin Profiles					
PR-AUSVFIN-30X60	30	16.7	600	27.9	27.9
PR-AUSVFIN-30X60	60	11.2	600	18.7	18.7
PR-AUSVFIN-30X60	90	8.4	600	14.0	14.0
Low Profiles					
PR-AUSLOW-30X20	30	16.7	600	27.9	27.9
PR-AUSLOW-30X20	60	11.2	600	18.7	18.7

Table 1

Profile	Spacing (mm)	Lm per m ²	TCR Spacing (mm)	Clips per m ²	Spacers per m ²
Round Profiles					
PR-AUSRND-40X40	15	18.2	600	30.4	30.4
PR-AUSRND-40X40	30	14.3	600	23.9	23.9
PR-AUSRND-40X40	60	10.0	600	16.7	16.7
PR-AUSRND-40X40	90	7.7	600	12.9	12.9
PR-AUSRND-30X40	15	22.3	600	37.2	37.2
PR-AUSRND-30X40	30	16.7	600	27.9	27.9
PR-AUSRND-30X40	60	11.2	600	18.7	18.7
PR-AUSRND-30X40	90	8.4	600	14.0	14.0
PR-AUSRND-30X60	15	22.3	600	37.2	37.2
PR-AUSRND-30X60	30	16.7	600	27.9	27.9
PR-AUSRND-30X60	60	11.2	600	18.7	18.7
PR-AUSRND-30X60	90	8.4	600	14.0	14.0
PR-AUSRND-40X50	15	18.2	600	30.4	30.4
PR-AUSRND-40X50	30	14.3	600	23.9	23.9
PR-AUSRND-40X50	60	10.0	600	16.7	16.7
PR-AUSRND-40X50	90	7.7	600	12.9	12.9
Waves Concave Profiles					
PR-AUSCNCV-60X23	-	16.7	600	27.9	27.9
PR-AUSCNCV-60X23	18	12.9	600	21.5	21.5
PR-AUSCNCV-60X23	30	11.2	600	18.7	18.7
PR-AUSCNCV-60X23	50	9.1	600	15.2	15.2
PR-AUSCNCV-90X20	-	11.2	600	18.7	18.7
PR-AUSCNCV-90X20	18	9.3	600	15.5	15.5
PR-AUSCNCV-90X20	30	8.4	600	14.0	14.0
PR-AUSCNCV-90X20	50	7.2	600	12.0	12.0
Waves Convex Profiles					
PR-AUSCNVX-60X27	-	16.7	600	27.9	27.9
PR-AUSCNVX-60X27	18	12.9	600	21.5	21.5
PR-AUSCNVX-60X27	30	11.2	600	18.7	18.7
PR-AUSCNVX-60X27	50	9.1	600	15.2	15.2
PR-AUSCNVX-90X25	-	11.2	600	18.7	18.7
PR-AUSCNVX-90X25	18	9.3	600	15.5	15.5
PR-AUSCNVX-90X25	30	8.4	600	14.0	14.0
PR-AUSCNVX-90X25	50	7.2	600	12.0	12.0

TCR mounted ceiling system

Before commencing, consider if you require painting the backing surface (ceiling or wall) black or a dark grey to highlight the beauty of the battens.

If you are suspending TCR rails from the ceiling, ensure that all rails are correctly secured using the recommended fastener for the substrate (eg: Dynabolt for cast concrete etc). Ensure that all rails are equally spaced no more than described in Generic Structural Design Certification, moving from one end of the area across the room. After securing each rail to the suspension clips, check the level for each rail before moving to the next. Check that all TCR rails are set to the same height for a level finish.

If you are planning on a cover profile to border the area, simply fix your L-shaped trims to the walls as a level border before you begin installation of the boards. The L-shaped trim should sit just under the final position of the boards, clearing them by no less than 5 mm. For further instructions related to seismic regions see **page 16**.

Place the Austratus clips onto the Austratus batten as shown in diagram 6, ensuring they are spaced appropriately as per **Generic Structural Design Certification**.

Now you're ready to start inserting your battens into the rails. Simply push the timber lengths up, clicking the clips into the rails. You can slide the clips for minor adjustments as required (see diagram 6). If you are installing batten profiles you can clip Austratus spacers onto the TCR rails before inserting, as you move across the room. Austratus Flat and Waves profiles do not require spacer clips as each Austratus wide clip includes spacing bars.

Spacing for Dowel profiles is measured from the centre of each profile to the next as shown in diagram 7.

As you work across the room, ensure each row of timber profiles is straight. Lasers guides can be used to ensure accuracy. It is recommended that Austratus Aluminium profiles are secured to TCR rails using Austratus metal clips employing the same method described in diagram 6. Hollow ends can be covered with Austratus end caps (see diagram 8).

Austratus aluminium profiles can be end-butted together with clip-on joiners. Always leave 2mm space for expansion over every 6m. Adjustments are simple and hassle free. Aluminium batten end caps are available for the standard offerings and are a satin black finish.

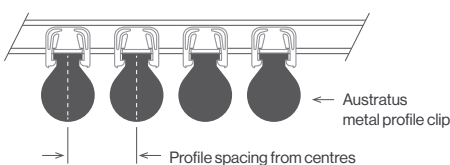

Diagram 7

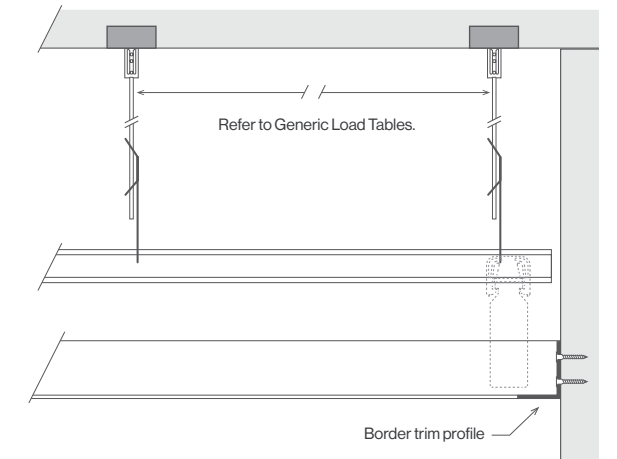

Diagram 5

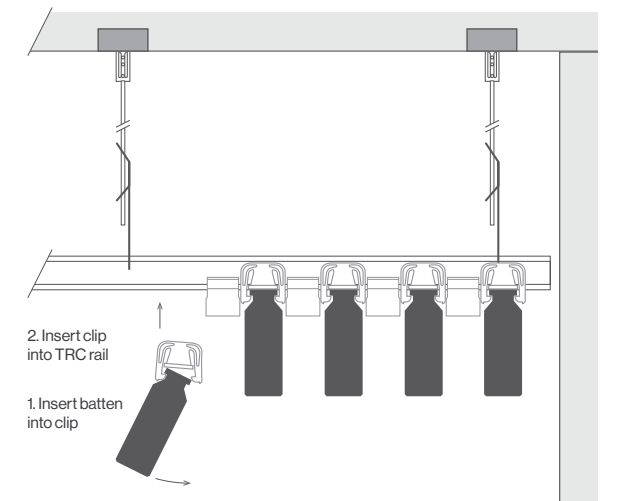

Diagram 6

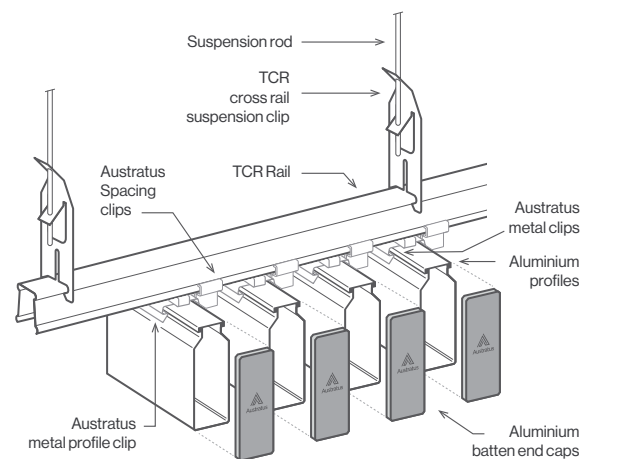

Diagram 8

For installation around utilities such as speakers; sensors; sprinklers etc, Austratus timber and aluminium profiles are easy to cut hatchway accesses or recessed. Austratus also supplies tins of touch-up paint to restore coated finishes for timber only.

Ensure that any smaller joins are properly supported with a short TCR rail and clips covering the adjacent profiles (see diagram 9).

Austratus has a natural acoustic rating, which can be further enhanced to suit various application requirements, with the addition of acoustic insulation. Simply cut the insulation to the required shape and size, then lay it on top of the timber profiles.

Insulation can be laid over Austratus battens and affixed with double-sided tape (see diagram 9).

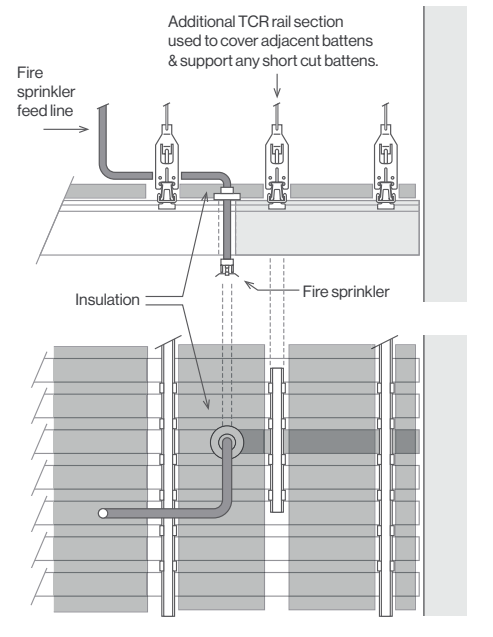

Diagram 9

Access hatches

Establish where the hatch is to be located on a reflected ceiling plan. Be mindful that Austratus is only designed to be self-supporting with no extra loads allowed for.

Use the **Generic Design Certification** under the **Resources** tab on the [Modinex website](http://www.modinex.com) to estimate the minimum TCR rail spacings. Ideally, this should be a minimum of 900mm. Hang the lock-in TCR rails 50mm from edge of the access hatch area.

Build the hatch from TRC rail lengths - screw a square or rectangle perimeter together (see diagram 10) using Pan Head Bi-Metal 8-18x16 Phillip Drive screws, then cut the timber battens to suit. Allow 5mm clearance on all ends.

NOTE: Test and adjust as required.

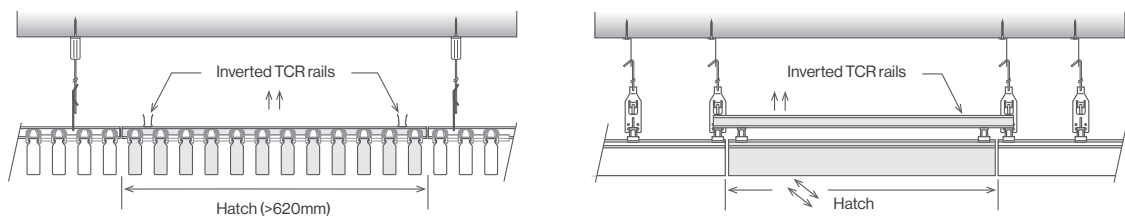
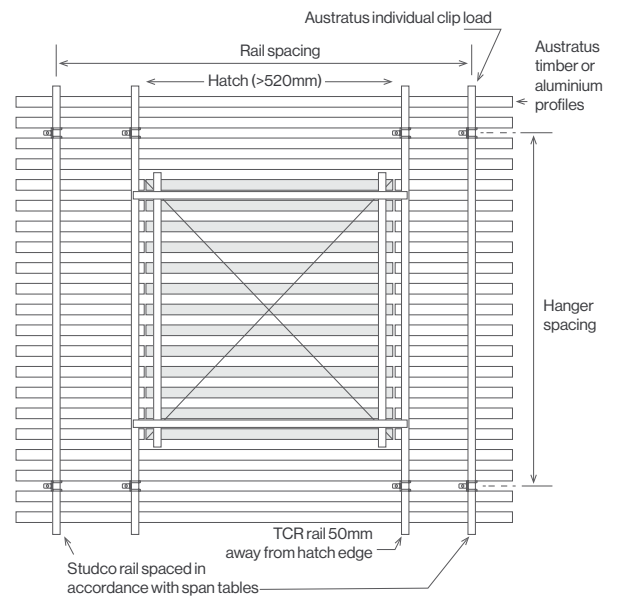

Diagram 10

Curved ceilings

Austratus suspended ceilings can be installed using convex and concave curved TCR rails (>1.5m radius) to give a beautiful wave effect (see diagram 11). Contact Modinex for more information on customised options for your installation.

Grid Layouts

When installing a grid section, first ensure that the TCR are installed in accord with the batten centres of the desired grid section size. Then follow the below order of assembly.

- Install long battens first, running perpendicular to the TCR (covered in detail on page 5).
 - Using the longest lengths of timber first will help minimise wastage.
 - Leave the spacing between these battens a little larger than the size of the grid, to enable easy insertion of the next batten.
- Measure and cut intermediate battens.
 - Note that when using battens with a width of 30mm or less, a small chamfer will need to be made to the Austratus Groove edge of the batten, to allow sufficient clearance of the TCR Clip.
- Attach Inline TCR Clips to intermediate batten.
 - Each batten must be held with at least 2 clips, spaced no more than 600mm apart.
- Starting from one corner of the space, Install intermediate batten into TCR.
- Complete one whole row of Intermediate battens, then slide the long batten across, to sit tight on the side of the batten.
 - Expansion gaps are not required, as the Austratus clips will slide to allow for this moment more than 600mm apart.

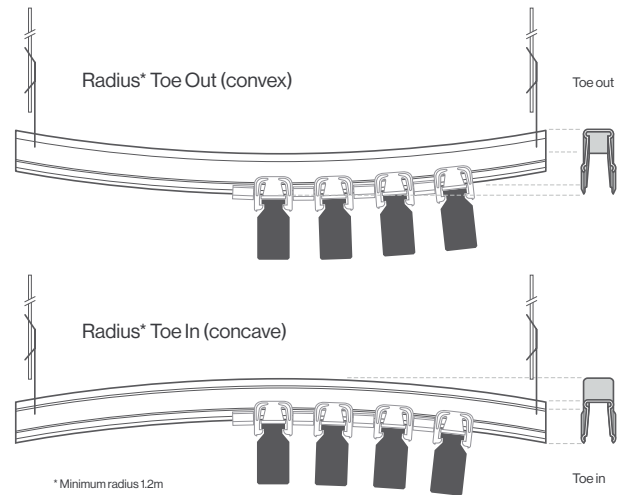

Diagram 11

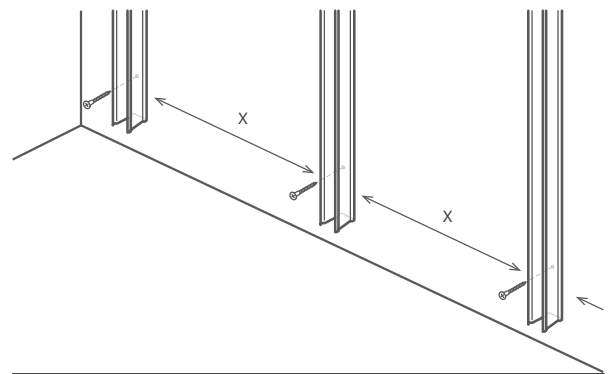

Diagram 12

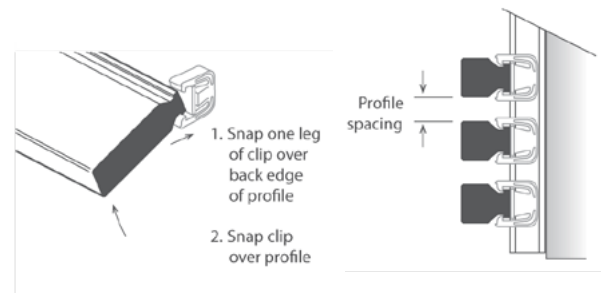

Diagram 13

Diagram 14

Wall installation

Horizontal Profiles

- Use load tables to establish rail centres then measure floor to ceiling heights and cut TCR rails to the required lengths (diagram 12).
- Pre-drill pilot holes through TCR rail stud or nogging behind.
- Use self-tapping metal or timber cup head screws to secure the section at nogging centres.
- Establish the spacing between battens to determine how many battens are required.
- Cut battens to length of wall required or use a joiner to meet required spans.
- Snap Austratus clips on to the top of the profiles as illustrated in diagram 13. Snap one leg in and press over profile.
- Once plastic clips are in place on the back face of the profile, slide the clip into position to correspond with the TCR rail.
- Firmly push the back of the timber profile with clip attachment into the TCR rail throat.
- Continue pressing clips onto profiles and mounting onto TCR rails. Use finned or flat Austratus spacer clips to pack out to the floor and between each Austratus profile (diagram 16).

Vertical Profiles

- Use load tables to establish rail centres then measure floor to ceiling heights and cut TCR rails to the required lengths (diagram 17).
- Pre-drill pilot holes through TCR rail stud or nogging behind.
- Use self-tapping metal or timber cup head screws to secure the section at nogging centres.
- Establish the number of battens required with respect to the spacing.
- Cut profiles to length of wall required.
- Snap spacer clips on to the top of the profile as illustrated in diagram 13 (on previous page). Snap one leg in and press over TCR profile.
- Firmly push the back of the timber profile with clip attachment into the TCR rail throat.
- Continue pressing clips onto profiles and mounting into TCR rails. Use finned or flat Austratus spacer clips between each Austratus profile as you move across the wall (diagram 19), dependant on the profile depth.
- Use the joiner clip to establish the floor offset distance as illustrated in diagram 18.

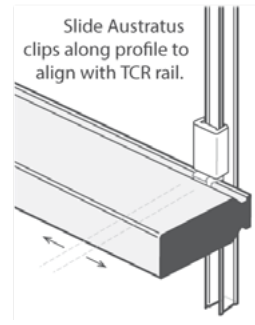

Diagram 15

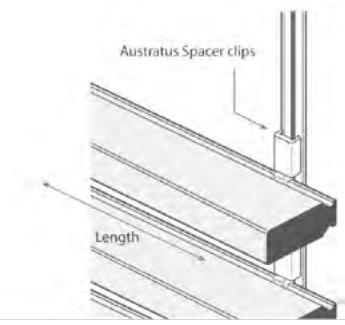

Diagram 16

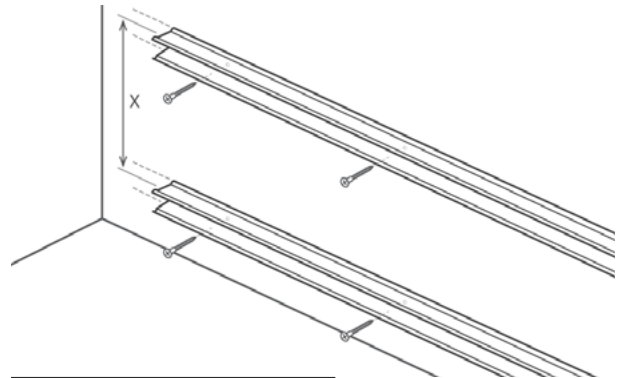

Diagram 17

Direct fix wall system

Ultra-Low Profile Installation

Ultra-Low Profile battens can be installed directly to wall using Austratus Direct Fix clips.

To affix Ultra Low Profile battens to walls, first mark aligned positions for clips on the wall (see diagram 20). Drill pilot holes through the clip and fasten to the wall with Countersunk screws.

Once all clips are in position, you can simply clip in the timber battens one at a time over the length of the batten, before moving on to the next.

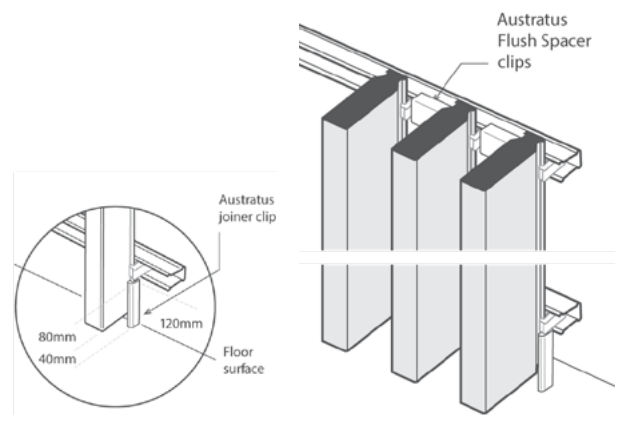

Diagram 18

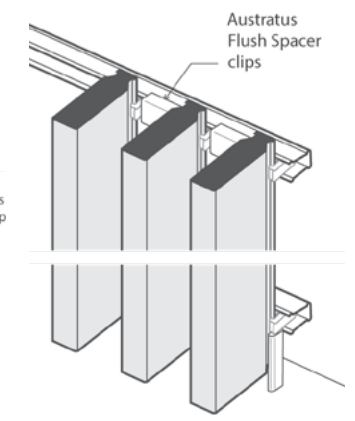

Diagram 19

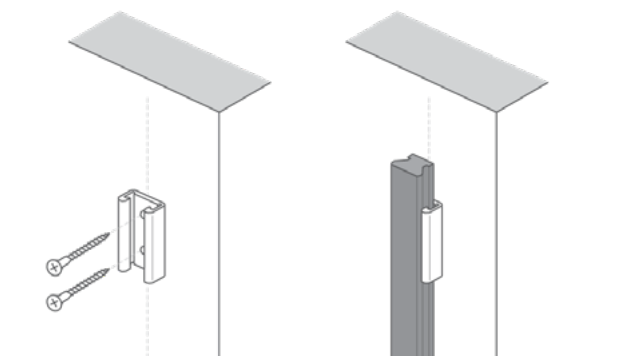

Diagram 20

Installation of curved walls

For curved wall installation, run TCR rails in line with batten. Fasten direct to your substrate as per **Generic Structural design Certification**, using appropriate fixings. The spacing distance for all rails should be checked as you work across the wall (see diagram 21, 22 & 23).

Installation of corners

Austratus can be applied to corners as shown in diagram 24.

Drill pilot holes through the clip and rail before turning it over and fastening it to the rail with fastening the screws. Once all clips are in position on the rails, you can simply clip in the timber battens one at a time, before checking alignment and moving on to the next row.

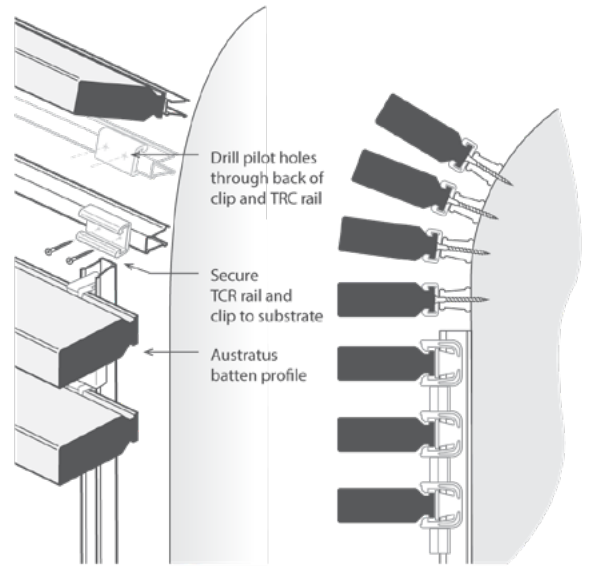

Diagram 21

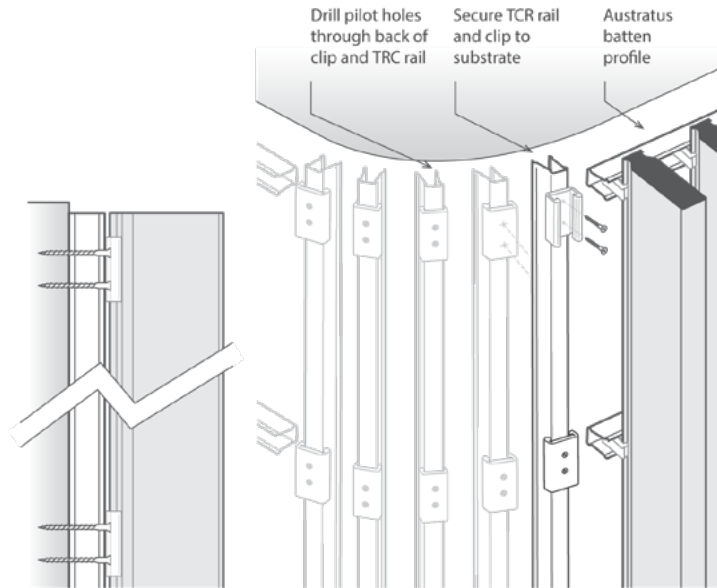

Diagram 22

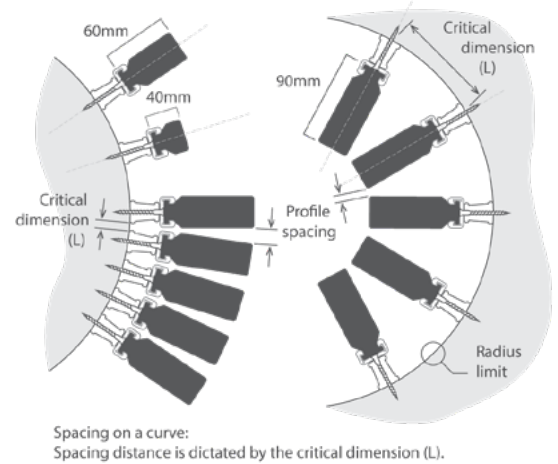

Diagram 23

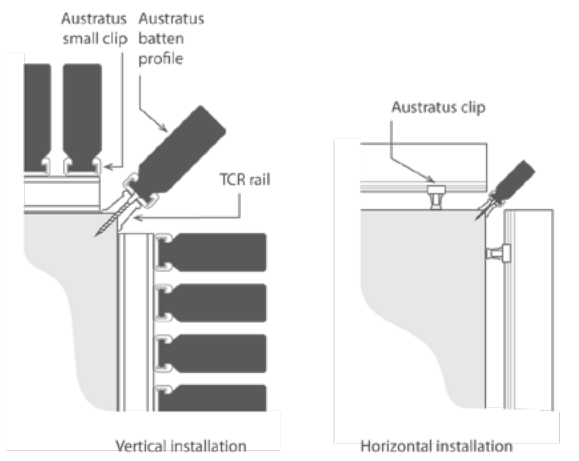

Diagram 24

Checking for Fire Compliance:

- Ask the architect or interior designer if the ceiling or walling system sits on a designated fire egress?
- Does the building have fire sprinkler systems installed or planned?
- Aluminium 6000 series (melts at 6600C) is deemed non-combustible. This is our standard offer for utilising nylon 66 (plastic) clips only.
- Metal clips melt at 14270C. Use metal clips and aluminium battens if in fire egress.
- Mild steel Studco ceiling grid system for the remainder of the assembly –Melts at 14270C.
- Hemlock and Cedar Group Number is 3 (ISO9705 – AS3837).
- Other species group ratings can be found on our website.
- Ensure that the client has run the design proposal by their respective fire engineers or certifier.

BCA Specifications C1.10 requirements for walls and ceiling linings

- A wall or ceiling lining system must comply with the group number specified in Table 3 and for buildings not fitted with a sprinkler system complying with Specification E1.5 have—
 - a smoke growth rate index not more than 100; or
 - an average specific extinction area less than 250 m²/kg.
- A group number of a wall or ceiling lining and the smoke growth rate index or average specific extinction area must be determined in accordance with AS 5637.1. Ensure a fire engineer has reviewed ISO5660 flow chart.

Class of building	Fire-isolated exits and fire control rooms	Public corridors		Specific areas		Other areas
	Wall/ceiling	Wall	Ceiling	Wall	Ceiling	Wall/ceiling
Class 2 or 3 Excluding accommodation for the aged, people with disabilities, and children						
Unsprinklered	1	1,2	1,2	1,2,3	1,2,3	1,2,3
Sprinklered	1	1,2,3	1,2,3	1,2,3	1,2,3	1,2,3
Class 3 or 9a Accommodation for the aged, people with a disability, children and health-care buildings						
Unsprinklered	1	1	1	1,2	1,2	1,2,3
Sprinklered	1	1,2	1,2	1,2,3	1,2,3	1,2,3
Class 5, 6, 7, 8 or 9b schools						
Unsprinklered	1	1,2	1,2	1,2,3	1,2	1,2,3
Sprinklered	1	1,2,3	1,2,3	1,2,3	1,2,3	1,2,3
Class 9b other than schools						
Unsprinklered	1	1	1	1,2	1,2	1,2,3
Sprinklered	1	1,2	1,2	1,2,3	1,2,3	1,2,3
Class 9c						
Sprinklered	1	1,2	1,2	1,2,3	1,2,3	1,2,3

For the purpose of this Table—

1. “Sprinklered” means a building fitted with a sprinkler system complying with Specification E1.5.

2. “Specific areas” means within—

for Class 2 and 3 buildings, a Open link in same pagesole-occupancy unit; and

for Class 5 buildings, open plan offices with a minimum floor dimension/floor to ceiling height ratio > 5; and

for Class 6 buildings, shops or other building with a minimum floor dimension/floor to ceiling height ratio > 5; and for Class 9a Open link in same pagehealth-care buildings, Open link in same pagepatient care areas; and

for Class 9b theatres and halls, etc, an auditorium; and

for Class 9b Open link in same page schools, a classroom; and

for Class 9c buildings, Open link in same pageresident use areas.

Table 4

Wind load Compliance for bistro areas with concertina doors:

1. Alternative profiles, spacings or materials are required other than those shown in the provided tables, contact Austratus for specific limits.
2. The span tables a resultable only for interior environments with wind loading where the system is direct fixed to the substructure (i.e foyer areas).
3. Individual profiles are not to exceed 6000mm in length and are to be $\leq 10\text{kg}$ in weight.

Cedar Fin Profile					
Wind Region	Profile Designation	Profile Width (mm)	Profile Depth (mm)	Profile Suitable	
N1	Fin	30	90	YES	
	Fin	30	60	YES	
	Fin	30	40	YES	
	Truncated fin	30	60	YES	
N2	Fin	30	90	NO	
	Fin	30	60	YES	
	Fin	30	40	YES	
	Truncated fin	30	60	YES	
N3	Fin	30	90	NO	
	Fin	30	60	YES	
	Fin	30	40	YES	
	Truncated fin	30	60	YES	
C1	Fin	30	90	NO	
	Fin	30	60	YES	
	Fin	30	40	YES	
	Truncated fin	30	60	YES	
C2	Fin	30	90	NO	
	Fin	30	60	NO	
	Fin	30	40	YES	
	Truncated fin	30	60	NO	

Table 5

Aluminium Fin Profile				
Wind Region	Profile Designation	Profile Width (mm)	Profile Depth (mm)	Profile Suitable
N1	Fin	30	90	YES
	Fin	30	60	YES
	Fin	30	40	YES
	Truncated Fin	30	60	YES
N2	Fin	30	90	YES
	Fin	30	60	YES
	Fin	30	40	YES
	Truncated Fin	30	60	YES
N3	Fin	30	90	YES
	Fin	30	60	YES
	Fin	30	40	YES
	Truncated Fin	30	60	YES
C1	Fin	30	90	YES
	Fin	30	60	YES
	Fin	30	40	YES
	Truncated Fin	30	60	YES
C2	Fin	30	90	NO
	Fin	30	60	YES
	Fin	30	40	YES
	Truncated Fin	30	60	YES

Hemlock Fin Profile				
Wind Region	Profile Designation	Profile Width (mm)	Profile Depth (mm)	Profile Suitable
N1	Fin	30	90	NO
	Fin	30	60	YES
	Fin	30	40	YES
	Truncated Fin	30	60	YES
N2	Fin	30	90	NO
	Fin	30	60	YES
	Fin	30	40	YES
	Truncated Fin	30	60	YES
N3	Fin	30	90	NO
	Fin	30	60	NO
	Fin	30	40	YES
	Truncated Fin	30	60	NO
C1	Fin	30	90	NO
	Fin	30	60	NO
	Fin	30	40	NO
	Truncated Fin	30	60	NO
C2	Fin	30	90	NO
	Fin	30	60	NO
	Fin	30	40	YES
	Truncated Fin	30	60	NO

Table 5

NOTE:
For interior environments only.

Suggested seismic installation details:

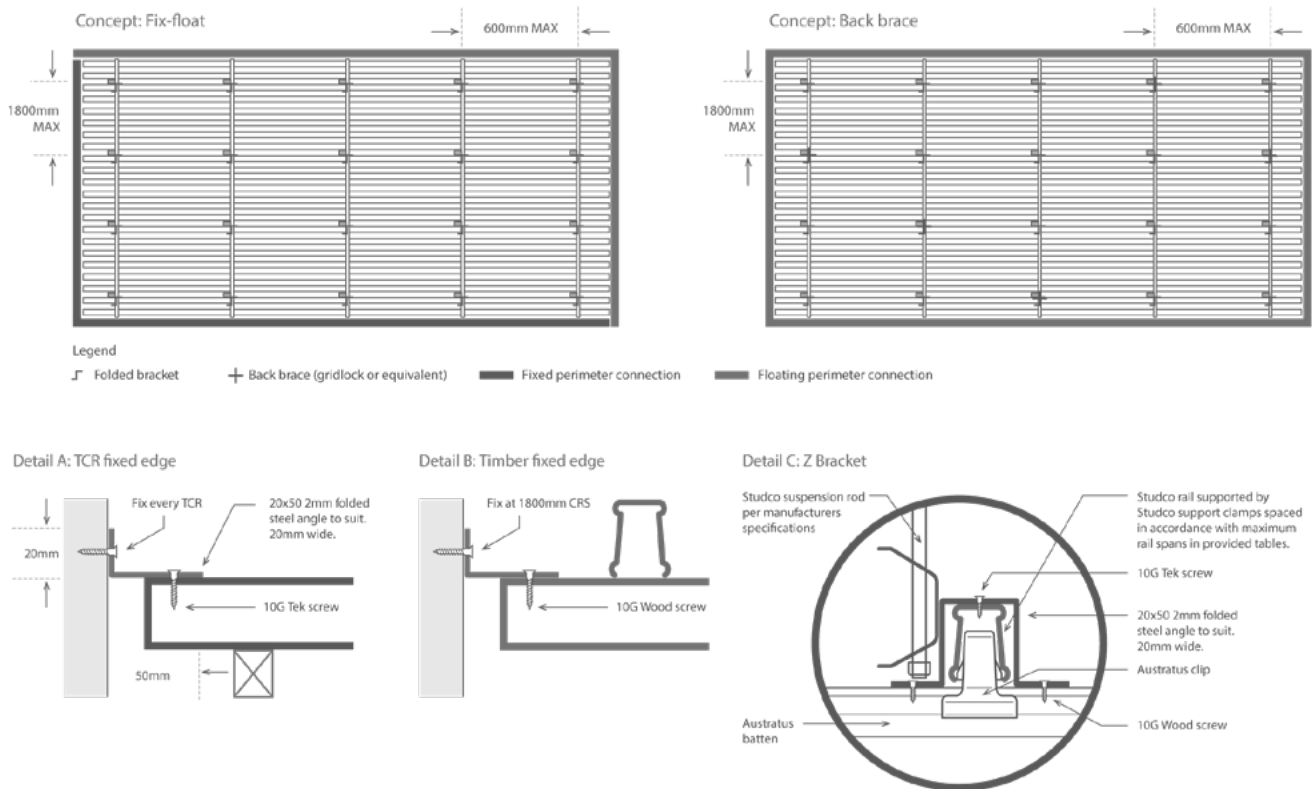

Wall fixings

Wall / column type	Fixings
Concrete	Multi MUS-3 M6x40
Metal batten	10G Tek screw
Timber	Pan Head Bi-Metal 8-18x16 Phillip Drive screw

NOTE:

- Approx capacity of Z bracket 35kg horizontally
- Refer to a certified engineer for specific engineering requirements.

Diagram 27

Austratus Sound Absorption Insulation Product Information

- Thermally bonded polyester fibre insulation designed to provide high performance sound absorption across a range of frequencies (refer to table 6).
- Available in a range of thicknesses and densities.
- Fibre blends engineered to provide maximum acoustic and thermal performance in diverse industrial, community, residential and commercial applications.
- Non-irritant; protective clothing and masks not required for installation
- Standard white colour; also available in black and grey upon request.
- Suggestion is to apply double-sided tape panels onto the top of the battens as per diagram 27.

Acoustic Performance Tested in accordance with AS/ISO 354-2006 XHD-25 & XHD-50								
Frequencies	125hz	250hz	500hz	1000hz	2000hz	4000hz	Alpha W	NRC
XHD-25	0.15	0.35	0.6	0.8	0.85	0.95	0.7	0.7
XHD-50	0.19	0.62	1.01	1.02	0.98	0.96	0.9	0.9

Table 6

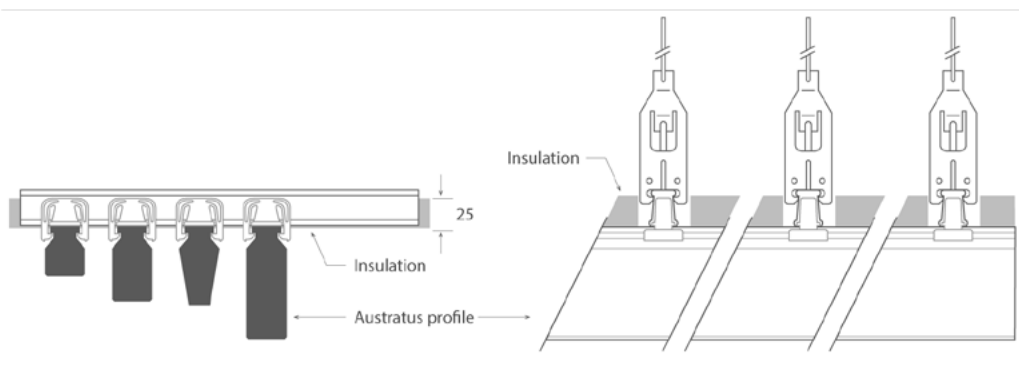

Diagram 27

Grade

Natural Select (min 2/3 Select, max 1/3 Standard according to AS 2796.2) Minimal surface checking allowed. Graded top face only.

Timber Batten Length

All timber is supplied in random length, ranging from 0.9m to 6.0m, unless otherwise specified. Average length = +/-2.7m. Max of 15% under 1.8m.

Colour Selection

Colour selection is not part of the grading process except with extreme variations according to the discretion of Austratus. Colours can vary significantly from rich browns to greys. This is a natural characteristic of timber.

Species Selection

All timber selected according to species classification as covered in known trade names, i.e; Western Red Cedar, Hemlock, Thermally Modified Hemlock, Spotted Gum, Ironbark and Blackbutt. Other species are available upon request.

Durability Rating (AS 5604) (Al fresco areas only)

Above ground durability rating for Blackbutt, Spotted Gum and Ironbark cladding is High (or Class 1). Rosewood, Western Red Cedar and Pacific Teak are Reasonably High. (Class Number 2)

Profile Accuracy

Above tolerance measured at time of manufacture is +/- 0.2 mm in dimension and profile. Due to variance in timber moisture and characteristics, boards may swell or contract individually when exposed to the elements.

Maintenance

Natural timber needs maintenance. Maintenance is required regardless of whether you want the rich pristine 'coated' timber look or the natural greyed off affect. The timber cells need to be hydrated and fed, to avoid them separating and shrivelling up which results in cracking and twisting. The frequency of oil application required depends on the following factors:

- Level of exposure to the sun.
- Level of local rainfall.
- The level of UV block provided by the coating.
- The extent of exposure to the western sun.

Advantage of oils

Austratus recommends Cutek oils and the coating must be reapplied as frequently as necessary to retain the natural beauty and colour of the timber if exposed to UV.

- brings out the natural beauty and character of the timber.
- penetrates and feeds the timber, providing dimensional stability.
- allows the timber to breathe.
- Tends to disappear and thin out when breaking down without blistering and peeling.
- Can be quickly reapplied by an unskilled person using a lamb's wool applicator.

We recommend and supply the Cutek Wood Preservative system. Ask for a Cutek brochure for further details.

Interior surface finishes

UV coatings are for use on interior applications; covered area out-of-weather use; and out of direct sunlight and rain.

1 Litre tins of touch-up paint are available from Austratus.

Interior finishes: Satin

Enhance the inherent depth of character and colour of Western Red Cedar with a satin finish.

- A premium professional, commercial grade finish.
- Environmentally friendly with no VOCs (volatile organic compounds).
- UV resistant.
- Clear Satin and Pecan Satin available.

Washes

- Maintenance-free finish.
- Internal and out-of-weather applications.
- Hemlock has an even texture, giving a consistent finish.
- Consistent colouring.

Satin Washes

- The combination of striking colours and satin washes on Hemlock are a designer's dream come true.

Matte Washes

- In-vogue colours and matte washes on Hemlock to help you reflect the sun, surf and beach.

Inspecting Aluminium finishes

When applying Austratus Wood/Paint Finish to Aluminium the following is inspected:

- **Cracking.** No visible checking or cracking of the Austratus Finish.
- **Chalking Resistance.** No chalking of the Austratus Finish in excess of that represented by No.8 rating based on ASTM D4214.
- **Colour Retention.** No colour change of the Austratus Finish greater than 5 (five) CIE Lab AE units calculated in accordance with ASTM 2244 Section 6.3 of the Austratus Warranty. Colour change shall be measured on the exposed paint surface which has been cleaned of oil, grease, chalk, oxidized film or other 3 contaminants and corresponding values shall be measured on the original retained batch panel. (Panel stored in the dark at temperatures below 30°C 86°F).
- **Gloss Retention.** Coated surface will exhibit gloss retention of a minimum of 30% of the original. Gloss retention shall be measured on the exposed paint surface which has been cleaned of oil, grease, chalk, oxidized film or other contaminants and corresponding values shall be measured on the original retained batch panel. (Panel stored in the dark at temperatures below 30°C 86°F).
- **Adhesion.** Adhesion of Austratus Finish when initially applied to test panels and measured by reference to AAMA 2604-02 Clause 7.4.2 will show no removal of the film.

