

- Timber
- Aluminium
- Concrete

AUG 2025

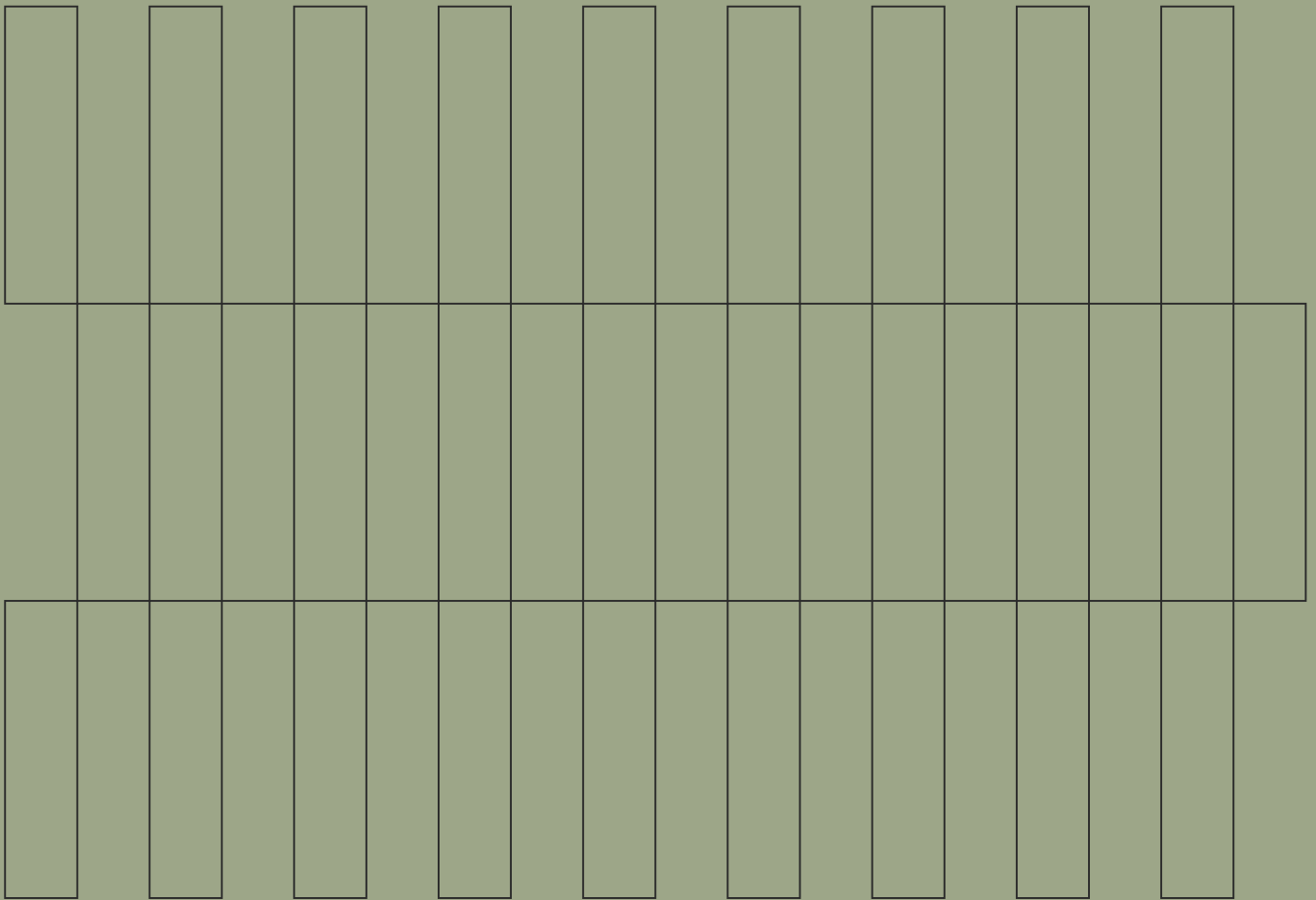

Millboard Decking

Installation Guide

Technical & User Guidelines

Fastening Millboard® to substructure

Warranties only apply if the recommended screws and fixing methods are used per guidelines. Boards may have up to +/-2% dimensional variance.

Following extensive trials we recommend and supply the best self drilling screws which should be used, a minimum of 20-25 mm in from the edge or end of the board. (Fig. 1). Two screws must be used where a board crosses a joist. On 196 mm boards to be supported by minimum of 18-20 mm. A 4 mm spacing between boards and 2 mm at the ends is recommended.

Top fixing, all boards normally screwed through the Lastane resilient surface that closes over the screw head. No pre-drilling or countersinking is required. Screws used to fix the end of Millboards to the joists should be driven at a slight angle to avoid being too near the edge. All screws should be stainless steel on any decking within 3-4 miles of the sea.

Cutting Millboards

Although Millboards are used to best visual effect when the detail of the ends are featured, should you need to cut them a sharp wood saw can be used and matching colour coating can be supplied. Always use a dust mask when sawing boards, to avoid inhaling dust and wear gloves. A dust bag must be used on electrical saws.

As the formed end of the board is lost when cut, we recommend these are used in less visual areas against a wall or fascia. On steps and prominent edges they should be faced with a step edge that is set a little higher to take the wear at that point.

If you need to cut the board down along the length, then reduce the joist centres accordingly. Exposed cut boards can be touched up with the coloured 'Touch-up coating', available in 500ml tins.

Factory Sealed

As boards are surface sealed to ensure they arrive on-site unstained, a phenomenon occurs where rainwater clumps in globules. This is normal for a few weeks and will settle down in time as elements break down this temporary extra seal.

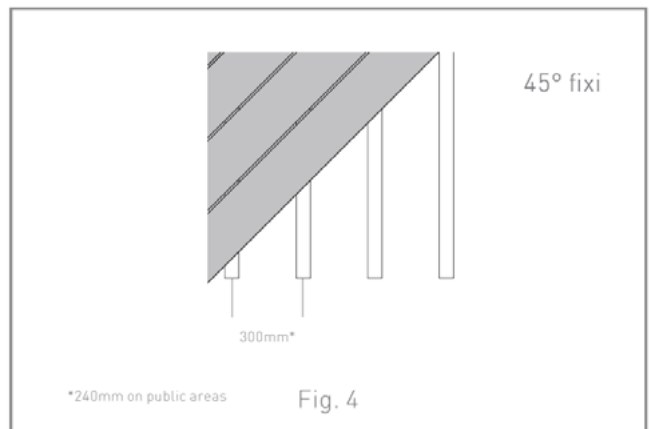
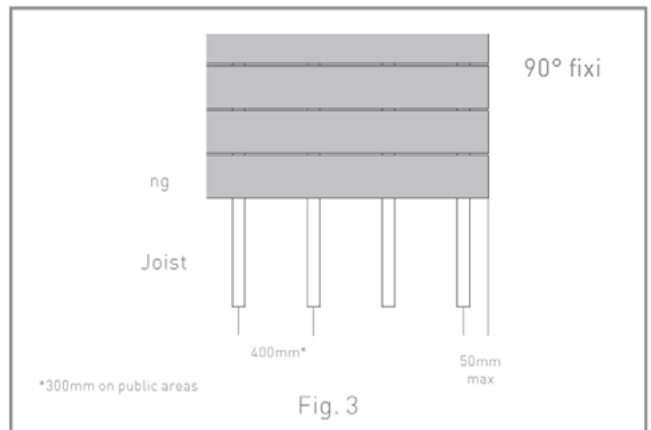
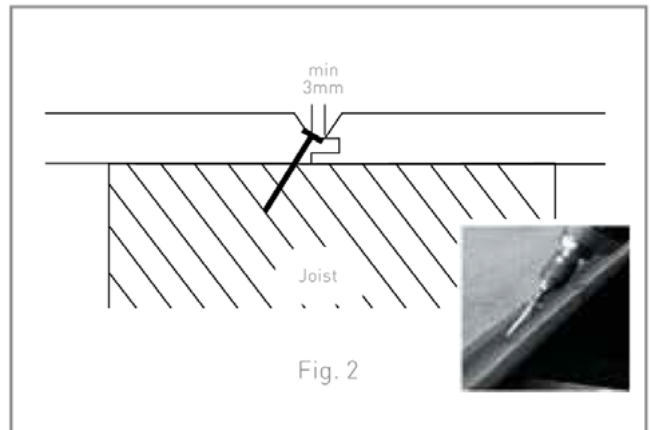
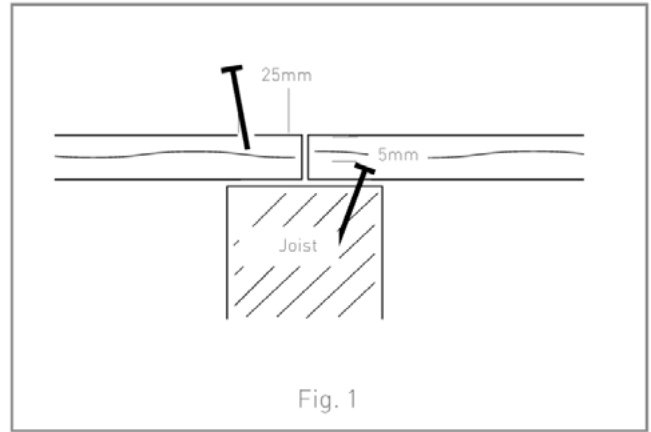

Joist spacing

Joist spacing of 400mm is recommended for normal residential use. On heavy commercial or bridges-balconies-moorings, and steps use 300mm spacing.

A minimum of 3 joists are required for any cut boards. All Millboards are reinforced for additional strength. For laying 450 to joist max 300mm centres, 240mm on commercial (See Fig. 3&4).

Half Weave and Board-and-End Grain

To continue the repeating designs, start every other new line of boards with a half board, this enables repeat to continue in correct fashion.

Tongue and Groove fixing

Millboard Tongue and Groove is fixed through the 'tongue', with the trimhead fixing at an angle into the joist as shown below, (See Fig. 2), leaving a 3 mm gap between boards to allow for drainage run off. We recommend to lay to a fall.

Care & Storage

Cleaning

Millboards are manufactured with non-porous material, therefore resists both algae growth and stains. We do not recommend the use of any kind of solvent, chemicals, abrasive cleaners, wax, oil or other household cleaners on Millboards as these may harm the boards finish. There is no need to pressure wash Millboards as dirt does not become ingrained. As the surface texture is non-porous, to remove dirt and grime wash with soapy water and brush with a broom before rinsing off, like internal flooring.

Damage to Surface

The resilient surface is very durable on normal wear & tear, however, mild damage should not normally show due to the varied texture and colours in the Millboards. Sharp metal objects such as narrow metal chair legs or spiked shoes may cause damage to the surface. Use of rock salt or grit may increase surface wear on decks as it is abrasive, white salt is the best option.

Weathering

Long term ageing tests have shown that Millboards are stable and inert, no adverse reactions are expected over time under normal conditions.

All colours have been carefully chosen and hand finished ensuring Millboard Decking will give an excellent overall natural effect throughout its life, certainly holding colour longer than wooden decking and many composites.

Choosing Colours

The darker colours of Millboard, can feel warmer than lighter colours on exposed, unshaded locations similar to decking in sunnier climates. The lighter colours should be specified in unshaded areas exposed to prolonged hot sun.

As with all flooring it is best to buy all you need at one time as batches made vary slightly, these variations are considered acceptable, similar to natural timber.

Do not install boards if colours are unacceptable or if for any reason you believe them to be defective. Colours may tone slightly in time, this is normal for decking.

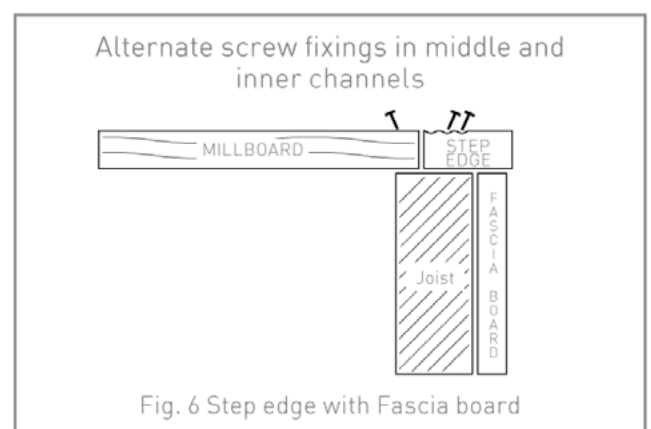
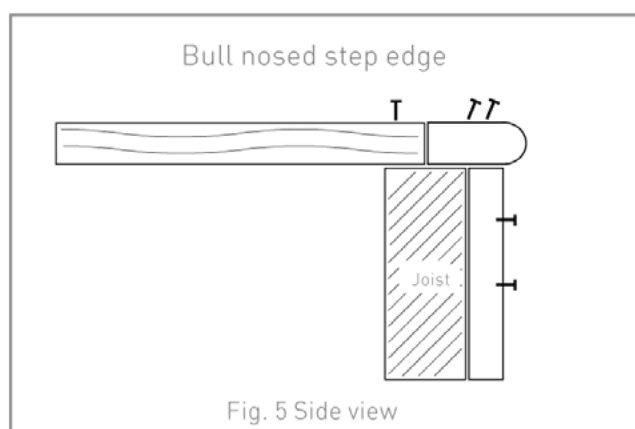

Storage and Handling

Millboards should always be stored on a “at surface or level bearers max 400 mm apart.

We strongly recommend using gloves when handling or cutting boards. Care must be taken when lifting Millboards as they can be more substantial in weight due to their length and full thickness than hollow core extrusions. Protective clothing, dust mask and safety glasses should be worn when cutting Millboards. Do not burn off cuts - dispose as refuse.

Pallets of Millboards should only be moved if safely strapped to the pallet. Take care when handling pallets.

Winter, Ice and Snow

A light application of granulated table salt can be used to keep your deck ice-free, stainless steel screws are available for use where de-icing salt is used regularly. Rock salt can be very abrasive. A 'spring-clean' of soap and water with a soft broom is recommended when winter is over.

Fascia Boards & Step Edges

We recommend that the purpose made 'step edges' are fitted at steps, and bull nosed or “at fascia boards at edges of decking to protect the ends and sides of the decking from excessive wear and to enhance the finished deck area where they can act as a positive edge to changes in levels.

Edge boards are available as a Bullnose version (Fig. 5) or as a ribbed design (Fig. 6). Both are available as rigid and flexible. The flexible type boards can be curved to follow a maximum convex diameter of 3m.

However, the boards must be warmed to at least room temperature before attempting gentle bending and fixing whilst working the curve with recommended screws at approx. 300 mm maximum intervals. Always pre-drill holes on the Ultra Flexible Fascia. Ensure boards have a minimum of 25 mm supported bearing on step edge and board.

Technical

Millboard Durafix 'lost head' top fixing - see the live Install video on our website



That's how easy the 'hidden' fixing is. Just screw straight in, no pre-drilling, counter sinking or fiddly clip fixings. The unique Lastane material closes back over the Millboard Trimhead fixing, leaving a virtually indistinguishable hole or at the most a very small entrance hole.

All our recommended board fixings have self-cutting tip and a torx drive head for ease of use. Ensure the head is 5 mm below the surface. We believe the most secure and best way of fixing a board is through the top. We recommend 2 fixings per joist and 3 fixings on the end of 196 mm or wider boards. It is advisable to coat the thread of all screws in a lubricating substance (i.e. silicone spray), to enable easy penetration through the Lastane layer.

Below are test results achieved by an accredited testing house on Millboard Lastane decking. With a Pendulum Testing (PTV)

1. Slip Resistance Test: In accordance with BS79.76. Minimum of 36 required for low slip potential.

Pendulum Test on dry Weathered Oak
= 81 classification: 'Excellent' anti-slip

Pendulum Test on wet Weathered Oak
= 65 classification: 'Excellent' anti-slip

Pendulum Test on dry Enhanced Grain
= 77 classification: 'Excellent' anti-slip

Pendulum Test on wet Enhanced Grain
= 55 classification: 'Excellent' anti-slip

Millboard passes the slip resistant tests in all directions, as Lastane covers the full surface area.

Installation

- Two fastener per joist minimum.
- Ends of each board must fall on a joist.
- Double joist or use blocking where two board ends meet.
- 25.5mm maximum cantilever.
- Install entire deck at same temperature.
- Install the deck boards starting from the outside edge of the platform and work toward the other end of the board. OR: Start installing from the center of the board and work out toward the ends of the board. Do not install by fastening each end first and working toward the middle.
- Continue installing deck boards, adhering to the gapping requirements. Ensure consistent appearance by aligning each plank so that the cathedrals of the emboss pattern point in the same direction.

Note: Cutting all ends of boards prior to installation is recommended.

2. Taber Abrasion Test using type H22 wheels: In accordance with ISO 9352.

The lower figure indicates lower wear (higher resistance to wear)

PRODUCTS	MG/1000 cycles
Millboard Lastane	302
Timber decking [softwood]	303

3. Fire Classification

Indicative tests using Underwriters UL94 test standard, samples passed V2 test criteria. All samples were self extinguishing.



Visit Millboard Decking product page for more information

June 2022 Publication

