

- Timber
- Aluminium
- Concrete

AUG 2025

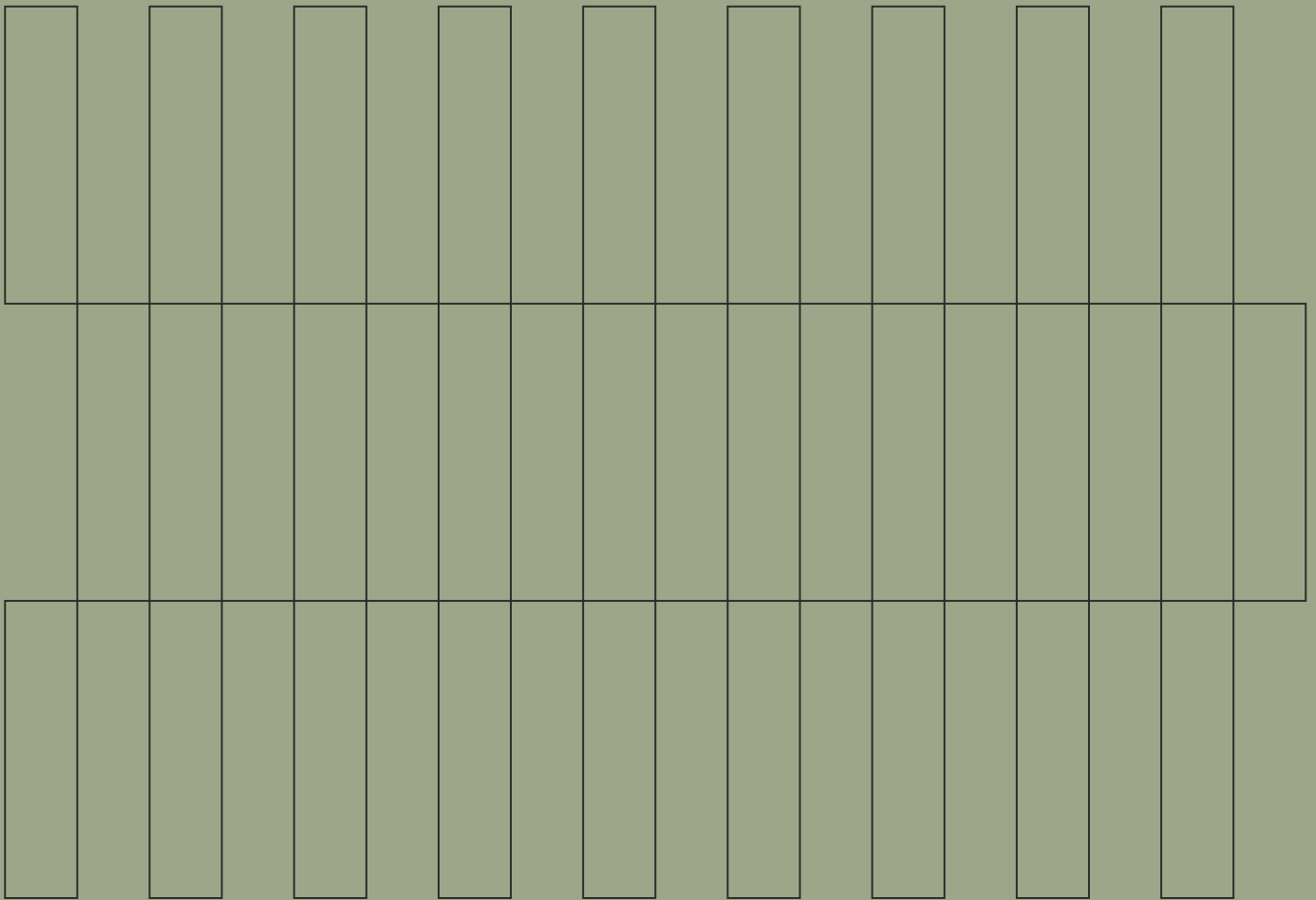

Cera Façade

Installation Guide for Timber Frame

Contents

Description	03	Vertical application	39
Safety Precautions	04	1. Points for Installation	39
Precautions	05	2. Install horizontal furring strips	40
Health and safety	10	3. Starter bar installation along sills	41
Design Criteria	12	4. First CERA FAÇADE panel installation	42
General Note for Installation	15	5. Clip installation	43
Accessories for the panels installation	16	6. Through wall flashing	44
Necessary tools	17	7. Outside corner finishing	45
Common installation procedure	18	• Metal outside trims	45
Frame Check	19	• Timber corner caps	46
Panel set-out	19	• Corner cladding	47
Installation of Sill Flashing	21	8. Inside corner finishing	48
Installation of water resistive breathable sheet (Sarking) with waterproof tape	23	9. Under eaves	49
<hr/>		10-1. Opening (Permanently-set Window)	50
Horizontal application	25	10-1. Opening (Sliding Window)	52
1. Points for Installation	25	11. Intersection with roof	54
2. Starter bar installation along sills	26	<hr/>	
3. First CERA FAÇADE panel installation	27	Other details	55
4. Clip installation	28	1. Overhang	55
5. Vertical joint	28	2. Coping	56
6. Outside corner finishing	29	3. Obtuse angle	57
• Metal outside trims	29	4. Installation around Ventilation Ducts	58
• Timber corner caps	30	5. Junctions with Other Materials	59
• Corner cladding	31	<hr/>	
7. Inside corner finishing	32	Applying Sealant	60
8. Under eaves	33	Waterproof sealer for uncaulked cut panel edges	60
9-1. Opening (Permanently-set Window)	34	Application of Touch-up Paint	61
9-1. Opening (Sliding Window)	36	Replacing a single panel	62
10. Intersection with roof	38	After Installation Completion	63



Description

1. The CERA FAÇADE System is a cavity-based extruded fibre-reinforced cement panel wall claddings. CERA FAÇADE panels are available in a range of surface profile patterns and prefinished colours. CERA FAÇADE panels are rebated to form hidden laps and are fixed with clips to form a drained and ventilated cavity.
2. The system incorporates a primary and secondary means of weather resistance (first and second line of defence) against water penetration by separating the cladding from the external wall framing with a nominal 15 mm drained and ventilated cavity.
3. CERA FAÇADE panels are manufactured in Japan to the Japanese Industrial Standard JIS A 5422 (fibre reinforced cement sidings) and are classified as a Type A, Grade 1 (fibre cement) sheet in accordance with ASTM C1186. Suitable for use in applications where non-combustible materials are specified by the Deemed to Satisfy Provisions of the 2019 BCA Vol 1, Clause C1.9(e).

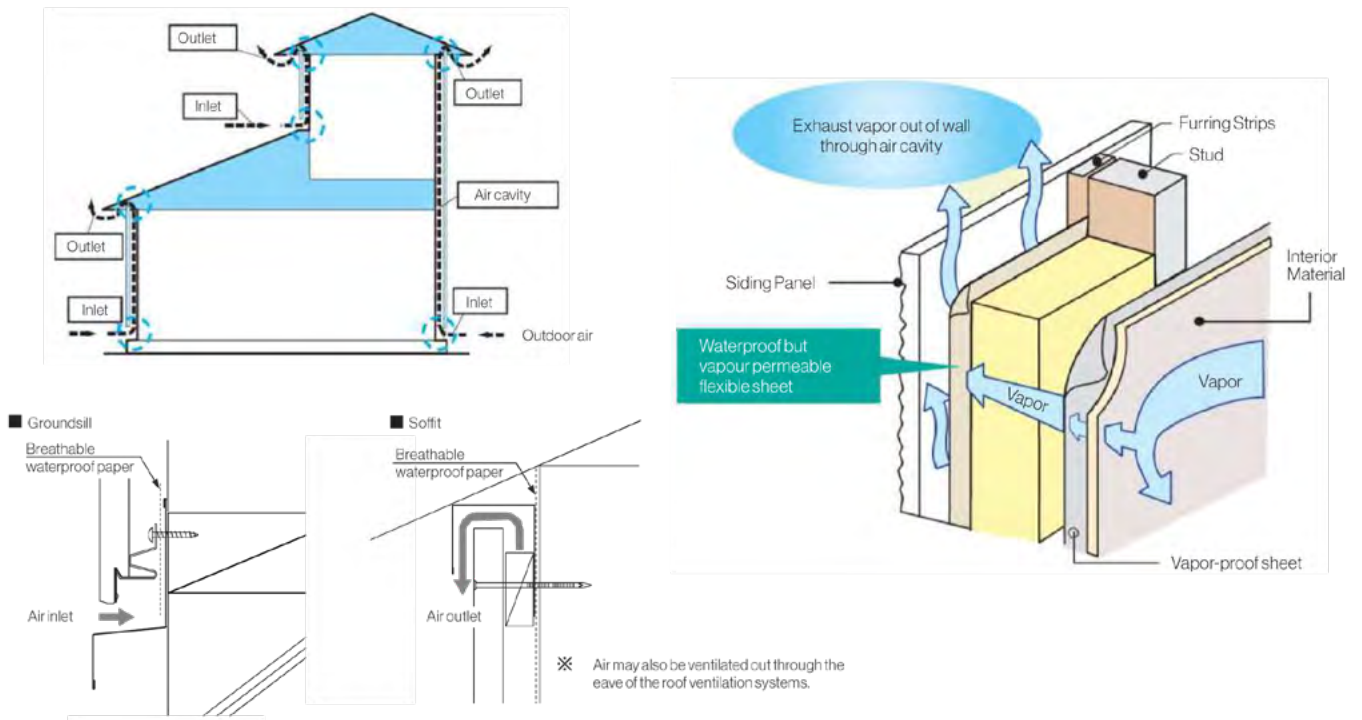
Details of the rain screen system



Safety Precautions

 Caution	
 Prohibited	<ul style="list-style-type: none"> • Keep the cladding covered before installation on site. Do not let the cladding be saturated or immersed in water before installation otherwise the CERA FAÇADE panels may warp or shrink after installation, causing rain penetration. • When storing CERA FAÇADE cover it with a weatherproof tarp as if it is left in the rain water can penetrate the unprotected edges or sides which can cause panel distortion.
 Very Important!	<ul style="list-style-type: none"> • CERA FAÇADE panels installation includes work in high places. Wear appropriate clothes and protective equipment, and check that the scaffolding is secure. • CERA FAÇADE panels are heavy. Take extreme care with safety during carriage; otherwise injury may be caused. • When storing, 2 cladding pallets may be stacked to a maximum 160 cm height. • CERA FAÇADE panels are made of cement. Wear gloves when handling them. In particular, when handling wet CERA FAÇADE panels, wear rubber gloves or other protective equipment. Otherwise your skin may be damaged. • When CERA FAÇADE panels are installed on a high place or balcony, together with clip fasteners, additional nails or other reinforcement must be secured into the CERA FAÇADE panels to prevent accidents and injury.

Precautions

Be sure to follow

Use the CERA FAÇADE panels safely and properly and follow the alarms and cautions below to prevent injury to users and others as well as damage to property.

The marks below indicate the levels of hazards and damages caused by inappropriate use.



Alarm

Indicates that erroneous handling may lead to death or serious injury



Caution

Indicates that erroneous handling may lead to injury or property damage

The marks below indicate what the users are required to follow.







Indicates prohibited action





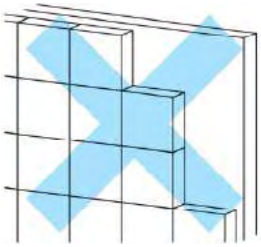

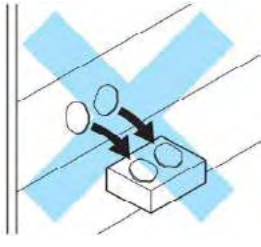



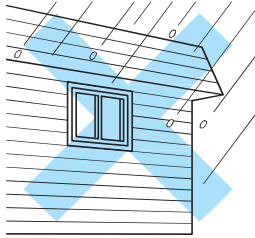

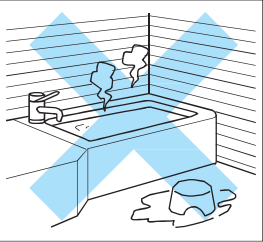
Indicates compulsory action (must)

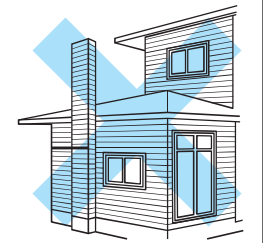

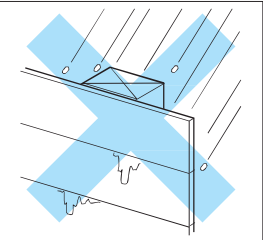

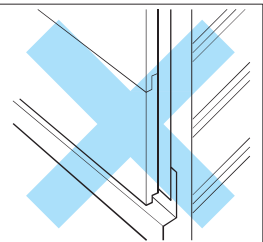
General precaution

Precautions for prevention of dropping		
 Alarm		<div style="display: flex; align-items: center; justify-content: center;">  <div style="margin-left: 10px;"> <p>Prohibited</p> <p>Direct fastening of tiles, etc. on the CERA FAÇADE panels</p> <p>If tiles are fastened directly on CERA FAÇADE panels, tiles may drop off, be broken or cracked.</p> </div> </div>
		<div style="display: flex; align-items: center; justify-content: center;">  <div style="margin-left: 10px;"> <p>Prohibited</p> <p>Fastening objects on the CERA FAÇADE panels</p> <p>The CERA FAÇADE panels may be broken or fastened objects may fall if the objects are fastened on the CERA FAÇADE panels alone.</p> <p>The CERA FAÇADE panels do not provide sufficient retention force. Objects shall be fastened on frames. Avoid joints of the CERA FAÇADE panels and fasten with consideration for distance from the edge.</p> </div> </div>

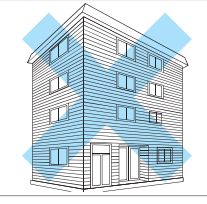
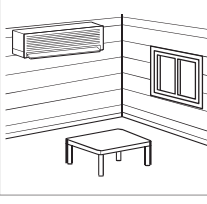
Shall not be used under the following conditions		
 Alarm		<p style="text-align: center;"></p> <p>Prohibited</p> <p>Installation on tilting parapets</p> <p>Parapets are subjected to severe conditions equivalent to those of roofs, unlike vertical walls, resulting in deterioration of coated film, freezing and leakage of rainwater.</p> <p>Please use roofing materials.</p>
		<p style="text-align: center;"></p> <p>Prohibited</p> <p>Installation on areas that are constantly subjected to water or steam</p> <p>They will be affected by water, heat, etc, resulting in warping, freezing, deterioration in strength and cracking.</p>
		<p style="text-align: center;"></p> <p>Prohibited</p> <p>Installation on centralized smoke stacks</p> <p>Moisture generated inside smoke stacks will leak through mortar and moisture will be absorbed by the CERA FAÇADE panels from backside, causing warping and freezing.</p>
		<p style="text-align: center;"></p> <p>Prohibited</p> <p>Installation on fences, etc. which get wet due to rain from backside</p> <p>Backside of the CERA FAÇADE panels is protected by sealer alone, and they may be warped due to repeated wetting and drying caused by water absorption from backside.</p>
		<p style="text-align: center;"></p> <p>Prohibited</p> <p>Direct fastening of the CERA FAÇADE panels on ALC/RC walls</p> <p>It could cause breakage of the CERA FAÇADE panels fastening areas or failing of the CERA FAÇADE panels.</p>

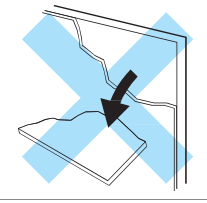
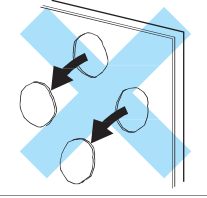
Shall not be used under the following conditions		
		<p>Prohibited</p> <p>Installation on fireproof structures and areas exceeding specified height</p> <p>Installation of the CERA FAÇADE panels on fireproof structures and areas that exceed 13m in height is not allowed.</p>
		<p>!</p> <p>Installation of the CERA FAÇADE panels as interior finishing material</p> <p>As for interior finish materials, emission of formaldehydes, etc. should meet the local Building Code or Regulations. Some CERA FAÇADE panels may satisfy those requirements however the designer should verify it as well as a proper installation method according to this manual.</p>

Precaution for on-site coating		
 <p>Caution</p>		<p>Prohibited</p> <p>Thick layer of multilayer finish coating or stucco cement</p> <p>Thick coating may cause separation, breakage or cracks due to insufficient adhesion strength.</p>
		<p>Prohibited</p> <p>On-site coating using materials not recommended for photocatalytic ceramic coat products</p> <p>Usage of recoating materials that are not recommended for the products may result in peeling of coating, etc.</p>

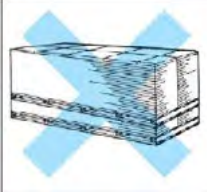
Precaution for storage, transportation and handling		
 <p>Caution</p>		<p>Very Important!</p> <p>The products shall be stored on a stiff and flat place.</p> <p>Storage on uneven or non-flat place may result in cracks and breakage of the products.</p>
		<p>Prohibited</p> <p>Do not place a pallet containing a small number of products under the one with a large number of products.</p> <p>It may cause cracks and breakage.</p>

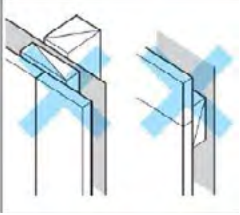
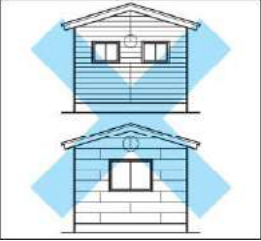
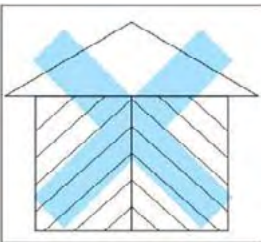
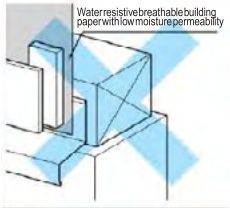
Precautions for prevention of rainwater leakage		
 Caution		<p style="text-align: center;">⊘</p> <p>Prohibited</p> <p>Butt joints</p> <p>Butt joints will generate a slight gap between the panels and cause rainwater leakage or freezing.</p>
		<p style="text-align: center;">⊘</p> <p>Prohibited</p> <p>Erratic installation where vertical joints are not a straight line</p> <p>Improper sealing, etc. may occur at joints between hat-shaped joiners and the CERA FAÇADE panels or between sill flashings and the CERA FAÇADE panels, causing rainwater leakage.</p>
		<p style="text-align: center;">⊘</p> <p>Prohibited</p> <p>Diagonal Installation</p> <p>When the CERA FAÇADE panels are installed diagonally, the amount of water that flows along the grooved joints increases at the bottom of the wall, causing water to flow into the wall, resulting in rainwater leakage.</p>
	 <p style="font-size: small;">Water resistive breathable building paper with low moisture permeability</p>	<p style="text-align: center;">⊘</p> <p>Prohibited</p> <p>Usage of water resistive breathable building paper with low permeability</p> <p>Do not use sarkings with paper with low moisture permeability low moisture permeability, such as PVC sheets. They will cause condensation.</p>
		<p style="text-align: center;">⊘</p> <p>Prohibited</p> <p>Installation without water resistive breathable building paper in exterior insulation structures</p> <p>Be sure to use water resistive breathable building paper and waterproof tapes, even if the exterior insulation method is incorporated. Improper installation may lead to rainwater leakage.</p>
		<p style="text-align: center;">⚠</p> <p>Very Important!</p> <p>The CERA FAÇADE panels shall be installed immediately after installation of water resistive breathable building paper and furring strips.</p> <p>If water resistive breathable building paper and furring strips remain uncovered, rainwater leakage may occur during rainstorm.</p>

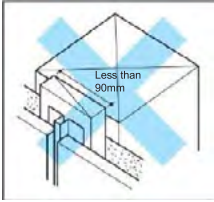
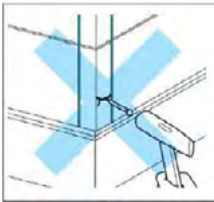
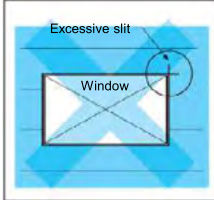
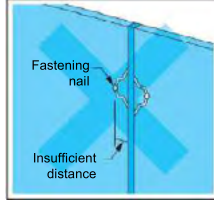
Precautions for prevention of cracks		
 <p>Caution</p>		<p>Prohibited</p> <p>Usage of furring strips less than 90 mm in width on joints</p> <p>When furring strips less than 90 mm in width are used, the distance from the edge of the CERA FAÇADE panels to fastening nails or screws become short, resulting in cracks, etc.</p>
		<p>Prohibited</p> <p>Nailing on areas with steel sheets without pilot holes</p> <p>Crack may be caused if CERA FAÇADE panel nails are hit directly on areas where sill flashings are overlapped, such as outside corners of the sill. Avoid sill flashing and hit nails after drilling pilot holes.</p>
		<p>Prohibited</p> <p>Excessive slit, installation of the CERA FAÇADE panels that are less than minimum allowable width without division</p> <p>They may cause cracks. Excessive slit could also lead to rainwater leakage and freezing.</p>
		<p>Prohibited</p> <p>Insufficient distance from the edge</p> <p>Insufficient distance from the edge could result in cracking or chipping of the edge. The distance from screw to the edge shall conform to the specifications.</p>

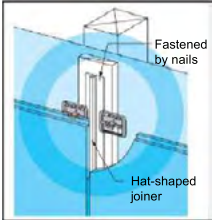
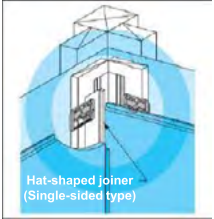
Precautions for prevention of lateral displacement (in installation with panel clips for horizontal application)		
 <p>Caution</p>		<p>Very Important!</p> <p>Hat-shaped joiners shall be fastened on studs at intervals of approximately 1m, using nails or screws.</p> <p>Lateral displacement of the CERA FAÇADE panels, breaking or swelling of sealant on vertical joints may occur if the hat-shaped joiners are not fixed.</p>
		<p>Very Important!</p> <p>Use hat-shaped joiners (one- side) on inside corners and beside openings.</p> <p>Lateral displacement of the CERA FAÇADE panels, breaking or swelling of sealant on vertical joints may occur if the hat-shaped joiners are not fixed.</p>

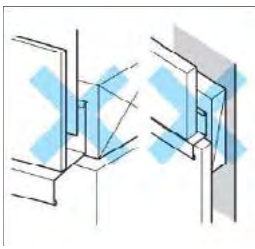
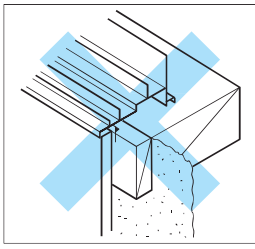
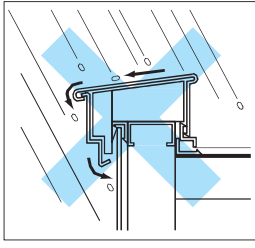
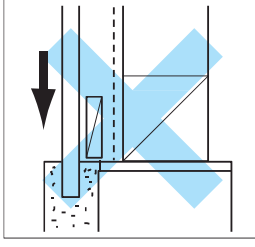
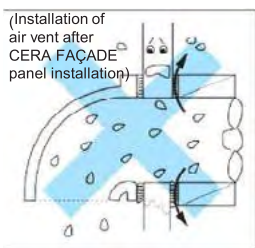
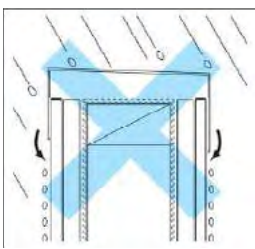
Precautions for prevention of base material deterioration		
 Caution		<p style="text-align: center;">⊘ Prohibited</p> <p>Butt joint with sill flashing and intermediate flashing</p> <p>Butt joint with sill flashing and intermediate flashing could lead to water absorption caused by capillary action, resulting in deterioration of base material or freezing. In addition, it does not conform to the standard installation method for the ventilated structure.</p>
		<p style="text-align: center;">⊘ Prohibited</p> <p>Installation under openings for sashes, etc. of limited overhang</p> <p>It could lead to staining and freezing of CERA FAÇADE panels due to water flowing down the sashes, etc. Prevent water flowing down the sash from flowing on the surface of the CERA FAÇADE panels.</p>
		<p style="text-align: center;">⊘ Prohibited</p> <p>Headboards that are tilted outward</p> <p>If head boards are horizontal or tilted outward, a large amount of rainwater flows on the external wall, causing stains and freezing.</p>
		<p style="text-align: center;">⊘ Prohibited</p> <p>Embedding in mortar portion of foundation or butt joint with the area</p> <p>The CERA FAÇADE panels will absorb water from embedded areas or butt joints, causing separation of coated film, deterioration of base material, freezing, etc. In addition, it does not conform to the standard installation method for the ventilated structure.</p>
	<p>(Installation of air vent after CERA FAÇADE panel installation)</p> 	<p style="text-align: center;">⊘ Prohibited</p> <p>Installation of air vents after installation of the CERA FAÇADE panels</p> <p>If air vents are installed after installation of the CERA FAÇADE panels, moisture tends to intrude into the wall, causing condensation, rainwater leakage, freezing, etc. Ventilation hoods and connecting pipes shall be installed before installation of the CERA FAÇADE panels, and the edges of water resistive breathable building paper shall be fastened by waterproof tapes, etc. to prevent intrusion of water.</p>
		<p style="text-align: center;">⊘ Prohibited</p> <p>Head boards with limited overhang, etc. that cause flow of rainwater along the CERA FAÇADE panel surface, or installation methods that prevent ventilation</p> <p>These conditions may cause staining and freezing of the CERA FAÇADE panels due to water running down from head boards. Condensation and freezing will be caused if the walls are not ventilated by the ventilated structure.</p>

Precautions for prevention of staining and discoloration

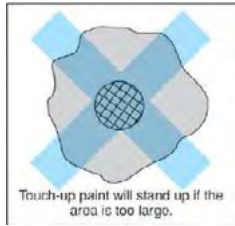

Prohibited

Improper touch-up for nail head, etc.

In touching up the nail head, if the area is too large, the paint is not fully mixed or sealing material is used, the area stands up after years of aging. Touch-up paint on nail heads should be limited to the minimum amount.

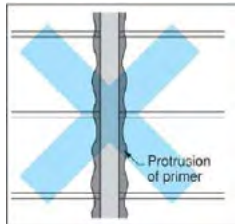

Prohibited

Protrusion of primer, sealing material and stain-proof agent

Protruded primer, sealing material and stain-proof agent will be discolored and stand out. Prevent protrusion by attaching masking tapes along the edge of the CERA FAÇADE panels and along patterns of the CERA FAÇADE panels.



Prohibited

Dividing or adding of touch-up paint for hydrophilic ceramic products

They may cause mismatching in color or insufficient performance.



Very Important!

Touch-up paint for hydrophilic ceramic products shall be mixed and stirred 30 minutes or more before use

If the paint is used immediately after stirring, the paint may not provide proper performance.



Prohibited

Cleaning using water!!

If any cutting dust settles on the face of the cladding, remove completely with either compressed air, soft brush or dry clean rag. Please do not clean off with water, otherwise a whitish patch may form on the face of the cladding.

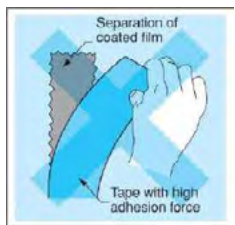

Prohibited

Attaching tapes with high adhesion force on the surface of the CERA FAÇADE panels

Don't use any tape on the surface of the cladding, other than recommended by KMEW when siliconing gaps. If tapes with high adhesion are used on the face of the cladding panels, the coated film on the surface could be damaged.



Very Important!

When cutting the CERA FAÇADE panel, always the finished side down on foam matt, therefore dust settling on the face of the cladding will be minimized. It also prevents physical damages to the surface by cutting.

Health and safety

1. Warning about silica dust

WARNING:
AVOID
BREATHING
SILICA DUST

Cladding panels contain silica. Inhalation of respirable silica dust can cause silicosis a potentially disabling lung disease. When drilling, cutting, or abrading cladding panels during installation or handling, (1) Work outdoors where feasible, otherwise use mechanical ventilation, (2) Wear a dust mask or, if dust may exceed the permissible exposure limit (PEL) defined by the local laws or regulations, use an appropriate respirator approved or recommended by the local authority, (3) Warn others in area. For further information, refer to material safety data sheet or consult your employer.

FAILURE TO ADHERE TO WARNINGS, MSDS, AND INSTALLATION INSTRUCTIONS MAY LEAD TO SERIOUS PERSONAL INJURY.

2. Handling and carrying

- One pallet weighs approx. two tons.
- Carry the panels by holding their lengthwise edges under your arm.
- Take extra care to avoid hitting anything with the panels or drop them, or the edges may be damaged.
- Don't touch panels with dirty hands.

< Transport by vehicle >

- When transporting the panels by vehicle, stack them flat.
- Tie panels with a rope and protect them with plates to avoid damage due to sudden braking.
- When loading/unloading panels, take extra care to avoid damaging them.
- When hoisting panels, put plates between the panels and ropes to avoid damaging the panels.
- Don't stack the pallet with more panels on top of the pallet with fewer panels.

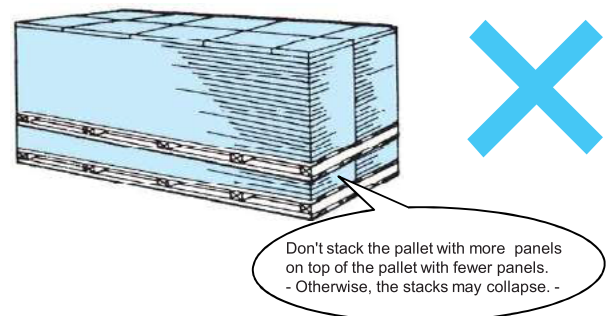
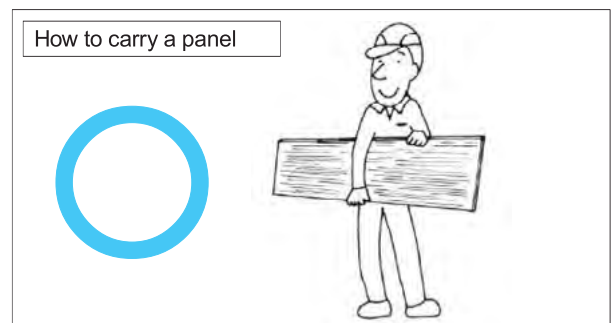

Health and safety

3. Handling and storage

- Store the panels flat and under cover. Keep the panels dry and off the ground prior to installation to avoid moisture conditions that could effect the quality of the work.
- The panels are not to be stacked more than 2 pallets high when stored temporarily at construction sites. Pallets should be loaded and unloaded with a forklift or sling. Taking care not to drop the pallet.
- Keep the panels clean when handling on site, and take care not to damage the edges.
- When necessary to stand panels on edge prior to installation, take care to avoid contact with rough and abrasive surfaces that could damage the factory-applied coating or sealer.
- The maximum number of the pallets to be stacked on a flat concrete floor in an indoor storage should be four.



Temporary outdoor storage:



Indoor storage:

a) On a pallet

b) On spacers

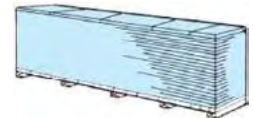
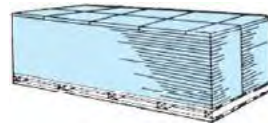

- Do not place panels directly on the ground.

4. Health precautions

- When cutting the panels, prolonged inhalation of a large amount of dust may be harmful to your health. Follow the instructions below.
 - Use a dustproof cutter equipped with an interlocked dust collector, or local exhaust equipment.
 - Wear a dustproof mask and dustproof glasses.
 - Work in a well-ventilated location.
 - Make sure to gargle and wash your hands.
- When using a solvent-based material, such as repair paint, waterproof sealer, sealant, and sealant primer, wear an appropriate mask or protective gloves, and work in a well-ventilated location.



Design Criteria

1. General

All design and construction must comply with the appropriate requirements of the current Building Code of Australia (BCA) and other applicable regulations and standard.

2. Physical Data

Finishes

- Photocatalytic coat on top of Ceramic coat layer which contains in-organic UV-absorbing substances, applied over an acrylic base-color layer.
- Hydrophilic coat on top of acrylic clear and base-color layers.
- Textures: CERA FAÇADE panels come in a wide variety of textures.
- Panel Dimensions:

PRODUCT	Core	Thickness	Length	Width	Weight
CERA FAÇADE N	Hollow	16mm	3030mm	455mm	Approx. 19-22kg/panel
CERA FAÇADE N	Hollow	18mm	3030mm	455mm	Approx. 22-25kg/panel
CERA FAÇADE F	Solid	16mm	3030mm	455mm	Approx. 24-27kg/panel

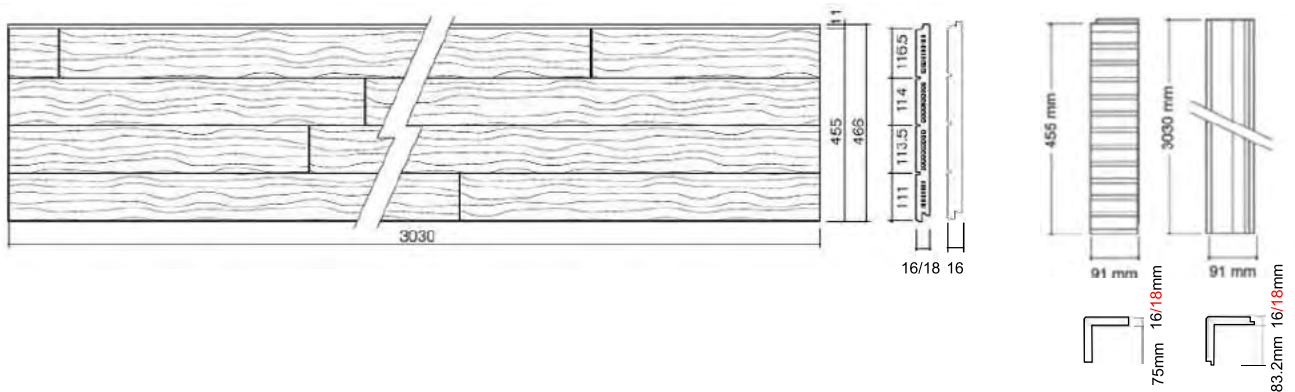

3. Fire

- The CERA FAÇADE System is suitable for use on exterior walls of BCA Volume 2 – Class 1 and Class 10 Buildings, (a) positioned a minimum of 900mm from an allotment boundary (other than the boundary adjoining a road alignment or other public space), and (b) positioned a minimum of 1.8 meters from another building on the same allotment (other than an appurtenant Class 10 building or a detached part of the same Class 1 building).
- Bush Fire Zones. The use of the CERA FAÇADE System on buildings located within designated bush fire zone shall be restricted by the requirements of AS.3959. The building designer is responsible for determining the Bushfire Attack Level (BAL) for the building accordance with AS 3959, which will in turn determine the suitability for use. The 16mm thickness of CERA FAÇADE panels exceed the minimum 9 mm thickness required for fibre cement cladding on external walls for compliance with BAL-40.

Design Criteria

4. Energy Efficiency

- Total construction R-Value depends on the insulation material use and the framing ratio. To achieve higher construction R-Values the wall insulation material shall be replaced with a higher R-Value insulation material.
- Refer to the table below for Total Construction R-Value:

CERA FAÇADE	R-Value (m ² ·K/W)	Air Cavity (mm)	Scenario	Stud Cavity (mm)	Insulation R-Value (m ² ·K/W)	9mm thk Interior Plasterboard R-Value (m ² ·K/W)	Total Construction R-Value (m ² ·K/W)	
							Winter	Summer
N product 16mm	0.076	15	1	70	None	0.06	1.5	1.3
			2	70	1.4		2.4	2.1
			3	75	1.5		2.5	2.2
			4	90	1.8		2.8	2.5
N product 18mm	0.086	15	1	70	None	0.06	1.5	1.3
			2	70	1.4		2.4	2.2
			3	75	1.5		2.5	2.3
			4	90	1.8		2.8	2.6
F product 16mm	0.062	15	1	70	None	0.06	1.5	1.3
			2	70	1.4		2.4	2.1
			3	75	1.5		2.5	2.2
			4	90	1.8		2.8	2.5

- Values are calculated in accordance with AS4859.1, and based on unventilated cavity.
- The Insulation R-Values (m²K/W) of glass wool were assumed.
- Frame type (timber or steel), size, or configuration are not considered in the calculations.
- If the vapour barrier on the outside of the studs was reflective on one side the R-value could be increased by 0.2 in all cases.

5. Regions of Application

Hollow Core panels – All regions in Australia

Solid Core panels - All regions of Australia except for areas located at an altitude of 600m or more in New South Wales (NSW), Victoria, Tasmania, Australian Capital Territory (ACT). However, Canberra (ATC) and Goulburn (NSW) are included.

6. Regions of Application

CERA FAÇADE system is suitable for use in Corrosivity Categories up to and including C4 - High according to ISO 9223 (AS4312).

7. Fixing Requirements

- The CERA FAÇADE system is suitable for the wind speed classifications N1 to N3 specified in AS4055.
- Refer to the following table for Fixing Requirement:

Wind Class	Steel frame	
	Panel Zone (Areas greater than 1,200mm from an External Building Corner)	Corner Zone (Areas less than 1,200mm from an External Building Corner)
N1	1 Panel Clip @ 600 ^{*1}	1 Panel Clip @ 600
N2	1 Panel Clip @ 600	1 Panel Clip @ 600
N3	1 Panel Clip @ 600	1 Panel Clip @ 600 + 1 Face Nail or Screw ^{*2}

- For horizontal application, panel clips must be fixed on every stud which maximum intervals are 600mm. For vertical application, panel clips must be fixed on every horizontal furring strip which maximum intervals are 500mm.
- Additional reinforcing screws (local purchase) or face nails (65mm, R8765R400) are required as shown on the following pictures.

Design Criteria

Horizontal application

Additional Reinforcing Nails for Wind Class N3

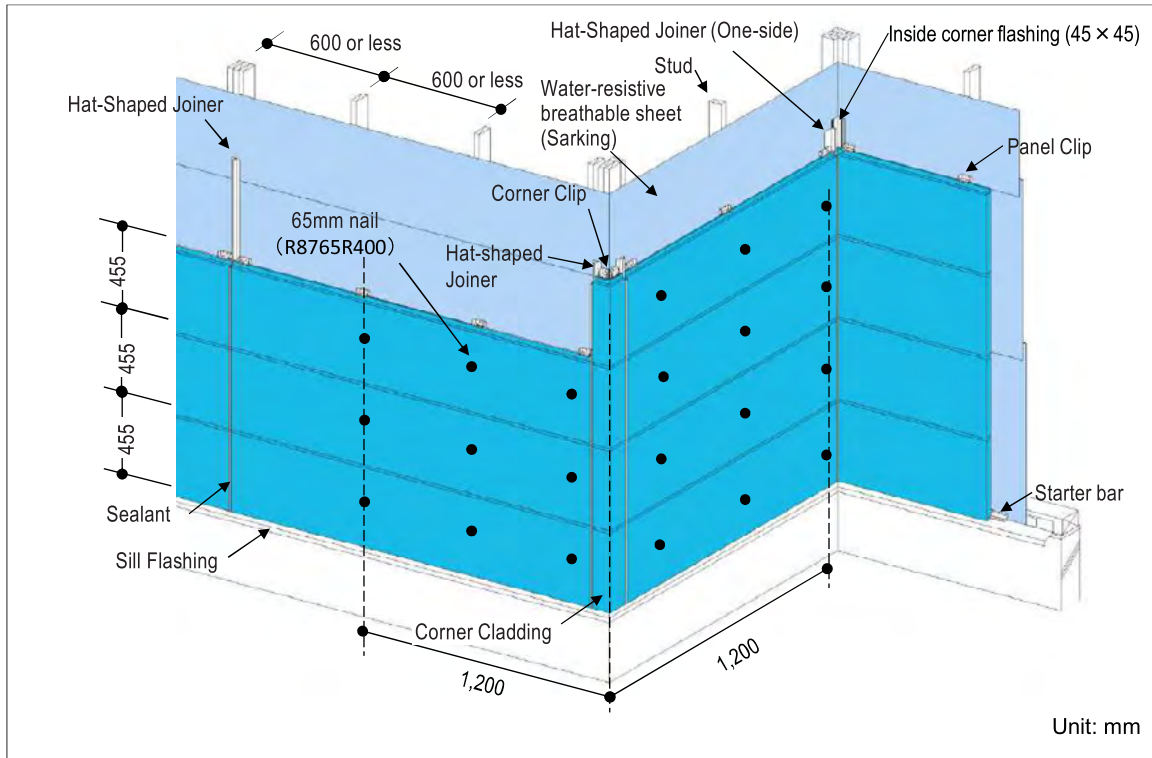

Vertical application

Additional Reinforcing Nails for Wind Class N3

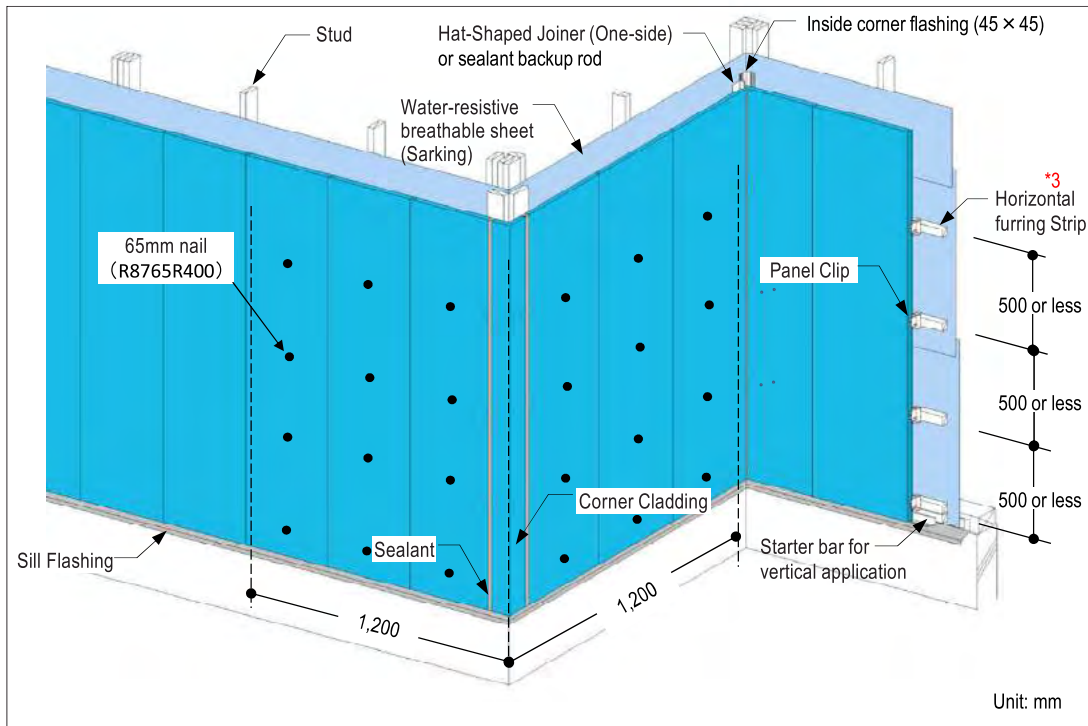

- The horizontal furring strips must have a minimum thickness of 30mm. The recommended size of the furring strip is 35mm thickness by 42mm width. At the sill, double 42mm wide or a 90mm wide furring strips (both 30mm or more thickness) should be used for the starter bars and the first panel clips.

General Note for Installation

Structure Unevenness

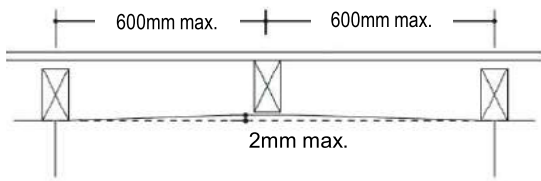

- If the sheathing board is noticeably uneven, reduce the unevenness to within 2 mm by using spacers, plywood boards, etc.

Cutting panels

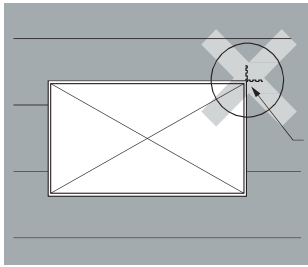

Use a dust collecting vacuum saw and dust-proof mats when cutting CERA FAÇADE panels.

 Over cutting may cause cracks on the panel surfaces or rain leakages.

Do not use water when cleaning dust off of the panels. Use compressed air or a clean dry cloth.

If small pieces are installed above or below a wide opening, it is recommended to follow example B and completely separate the smaller section.

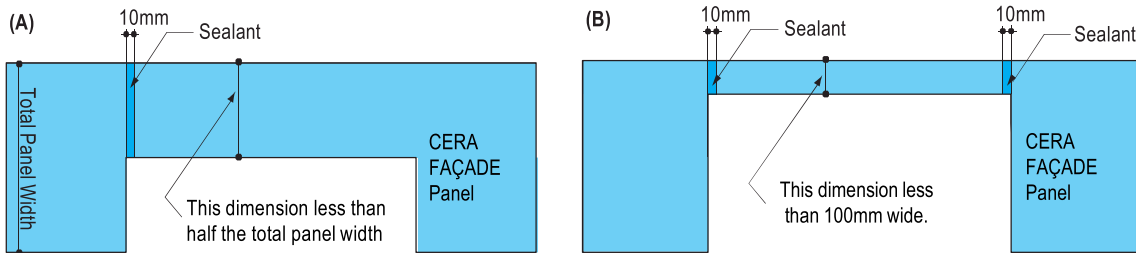

Example A: If the cut piece above or below an opening is less than half the total width of the panel but greater than 100mm wide, separate the panel into 2 pieces and fill the gap with sealant (approx. 10mm wide) at one edge of the opening.

Example B: If the cut piece above or below an opening is less than 100mm width, separate the panel into 3 pieces and fill the gaps between each piece with sealant (approx. 10mm wide).

Note 1: Minimum panel dimension is 60mm. Avoid cutting panels smaller than this width.

Note 2: In case of T-jointer instead of sealant, the gap for sealant of approx. 10mm is not required.

Fixing panels

- The bottom or first row of CERA FAÇADE panels are to be fixed on either starter bars for horizontal or vertical application.
- CERA FAÇADE panels are to be fixed with panel clips for both horizontal and vertical applications.
- A clip is to be fastened with a clip screw.
- However, clips cannot be used to install panels in some areas where the shiplap portion of the panel is removed such as the eave and the top / bottom of the opening.
- In this case, put spacer 15s or furring blocks/strips (pressure treated), and fix the panel to the studs through spacer 15s or furring blocks/strips with 65mm nails or screws. Pre-drill a hole (2mm) for a nail and then fasten it. Make sure that the required clearances from the panel edges should be kept as shown on the diagram.
- Be sure to apply touch-up paint onto the nail heads.

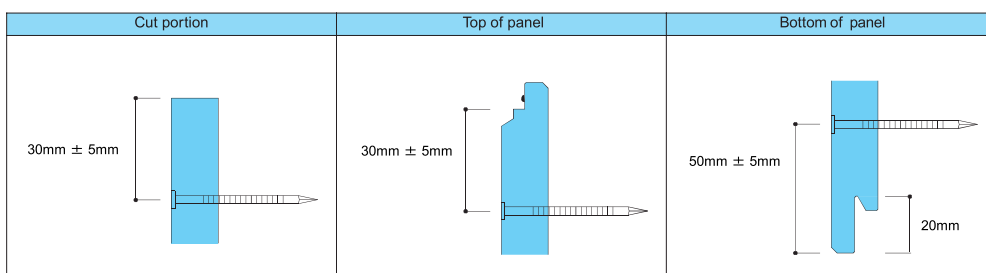

Accessories for the panels installation

Common Accessories

Panel Clip (B10115)
hot-dip zinc-aluminium-magnesium alloy coated steel
Dimensions: 15 mm, 66 mm, t=0.8mm, 60 mm

Hat-Shaped Joiner (B2716)
Zinc/aluminium coated steel with anti-adhesion tape
Dimensions: 49 mm, 9 mm, 20.8, 4.5, 49, t = 0.3mm, L = 3030 mm

One-Side Hat-Shaped Joiner (B2716K)
Dimensions: 54mm, 9 mm, 17.8, 16.3, 54, t = 0.3mm, L = 3030 mm

Spacer 15 (RY82S15)
Dimensions: 45 mm, 15 mm, 40 mm

Metal corner trim
t = 0.35 mm
ℓ = 3,030 mm
Material: Hot-dip zinc/aluminium coated steel with a polyester paint finish

Trim Section for 16mm panel (RE213)**
Dimensions: 35 mm, 3.5 mm, 17.3 mm, 1.25 mm, 28 mm, 12.5 mm

Repair Paint (B•••)

65 mm Nail (B8765R400)
Stainless Steel Grade SUS304
Dimensions: 5 mm, 65 mm, φ 3.0

Clip Screw (RY8830)
Stainless Steel Grade SUS410
Dimensions: 25 mm, φ 4.2

Accessories for Horizontal Application

Corner Clip (B10153)
hot-dip zinc-aluminium-magnesium alloy coated steel
Dimensions: 15 mm, 49 mm, t=0.8mm, 45 mm

Starter Bar (B10152) Hot-dip zinc-aluminum-magnesium alloy coated steel (ZAM)
Dimensions: t=0.8mm, ℓ=3030mm, 22.4, 15, 30

Accessories for Vertical Application

Corner Clip(RE10158)
hot-dip zinc-aluminium-magnesium alloy coated steel
Dimensions: 15mm, 59 mm, 70 mm

Starter Bar (B10157HG)
Material: hot-dip zinc/aluminium coated steel with a polyester paint finish.
Dimensions: t = 0.8mm, ℓ = 3030 mm, 35.6 mm, 36 mm

Accessories for the panels installation

Modinex Accessories (Trims)

The following Modinex accessories can be used ONLY for CERA FAÇADE F (solid core) product.

For CERA FAÇADE N (solid core) products, Hat-Shaped Metal Joiners and locally purchased flashing should be used with sealant finish in the same manner as before.

MDX-016 and MDX-010 for vertical joints

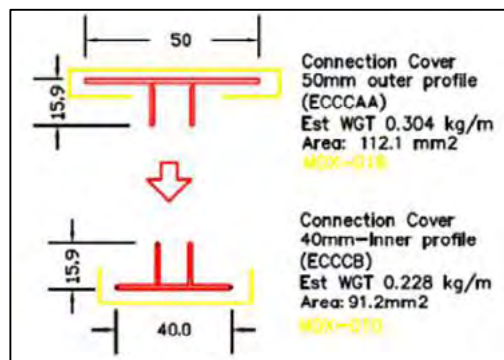

For the solid core product, Water-Sealing Materials (WSM) is not required to the trims.

However, appropriate waterproofing methods should be applied to each trim to minimize water in to the cavity as a local common practice as necessary, for which KMEW is not responsible.

MDX-009 and MDX-011 for internal corner

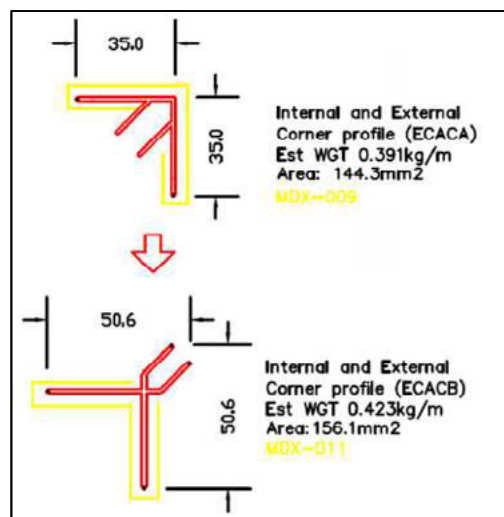

ECA 20x20 for Obtuse angles

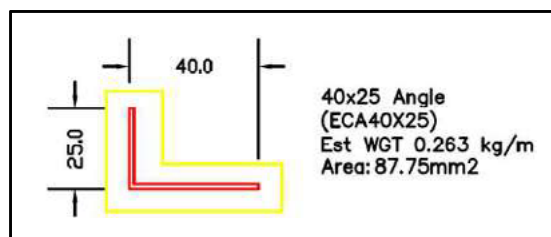

MDX-007 and MDX-005 for vertical junction with other exterior wall materials

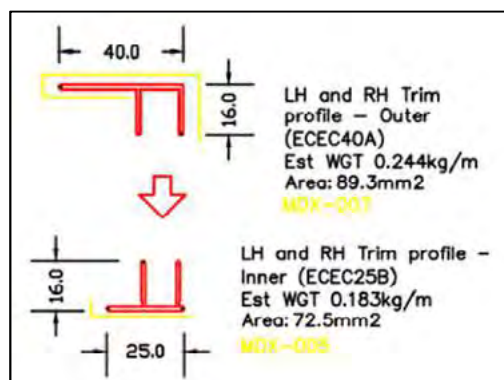

Necessary tools

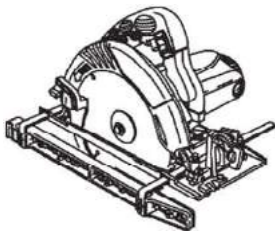

Dustproof circular saw

Manufacturer: (Makita Corp./Hitachi Koki Co., Ltd.)



Dust collector

Manufacturer: (Makita Corp./Hitachi Koki Co., Ltd.)



Electric drill/screwdriver



Tracker

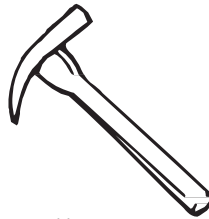

Hammer

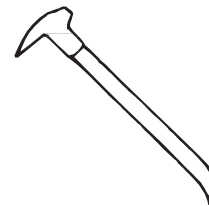

Nail claw

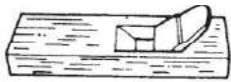

Melamine planer



Tape measure



Hand file

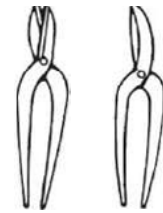

Tin shears



Melamine planer

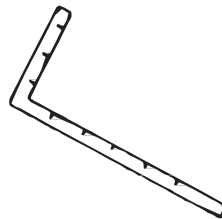

Framing square



Sealant cartridge gun



Plumb bob

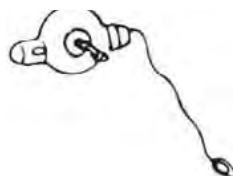

Chalk pot

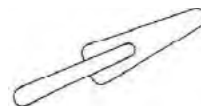

Sealant spatula



Slate saw

Accessories for the panels installation

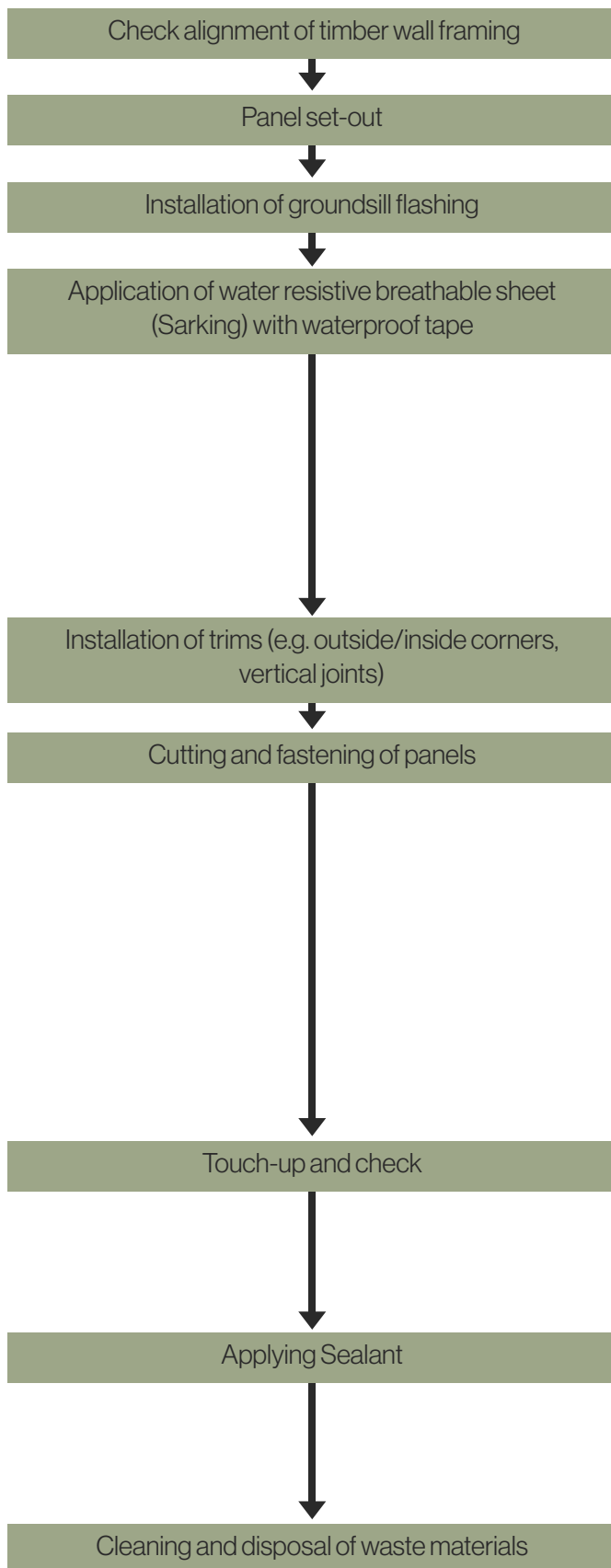

Key points

- The unevenness or the difference in level of the framing must be 2 mm or less.
- Take the appearance, material waste, and workability into consideration.
- Mark a reference horizontal line.
- Ensure that the sarking has no breaks or wrinkles.
- Provide sufficient overlap.
- Overlap the sarking by 90 mm or more along the vertical directions, 150 mm or more along the horizontal directions, and two spans at the inside corners as detailed on page 24.
- Apply waterproof tape around openings.
- Check the perpendicularity using a leveling tool.
- Ensure that panels are securely fastened.
- The clips must not rattle or loosen.
- There must be sufficient clearance between the panel and Sill Flashing, through wall flashing, and soffit flashing. There must be no gaps in the shiplap joints.
- Follow the specifications of the nailing position on panel edges
- Apply the repair paint to the nail heads and partial flaws.
- Check for the omission of nails and clean panels.
- Check the weather before applying sealant for the panels.

Panel set-out

Horizontal Application

- When laying out the panels, take into consideration the appearance of the building, the length of provided accessories and how to minimize material waste.
- Layout sealant joints in advance to create an aesthetically pleasing finish.
- Include the inside dimension of the pre- formed outside corners in consideration of panel arrangement.
- Vertical joints should be aligned with studs.
- Include the sealant joint width (10mm) for each vertical joint.
- Pay attention to window locations and eave soffit height to provide more than 150mm if possible (minimum 60mm) for the panels above and below window frames (B, C, figure below) and panels below the soffit (A).
- Panel set-out should be prepared in advance and provided to the installers.

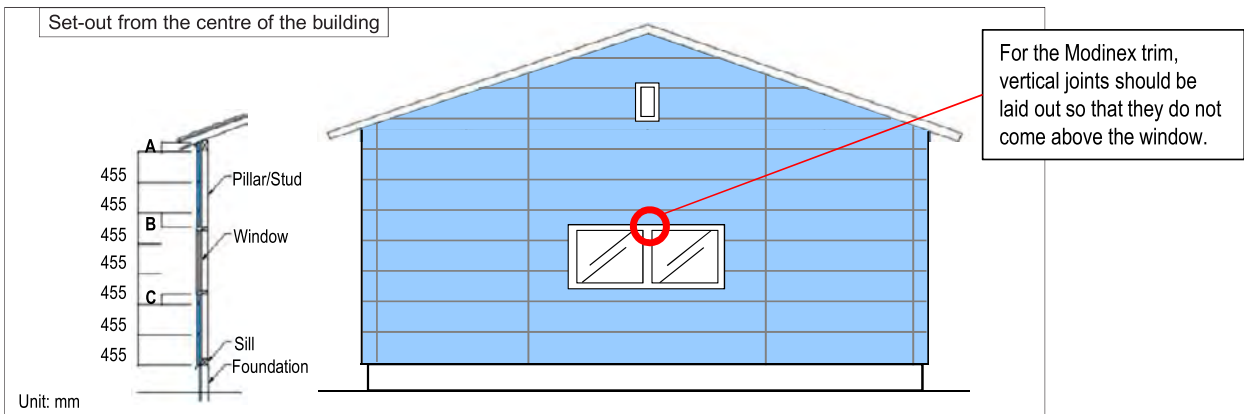

Vertical Application

Include the inside dimension of the pre- formed outside corners in consideration of panel arrangement.

- The furthest left and right panels should be at least as wide as the side of the outside corner cladding.
- Two methods for avoiding narrow panel pieces are included in this manual: “Centering the Joint” or “Centering the Panel”. Refer to the next page for these methods.
- Arrange the panels from the center of the building wall. Make sure the panels along both window frame sides (B and C) are at least 60mm wide.

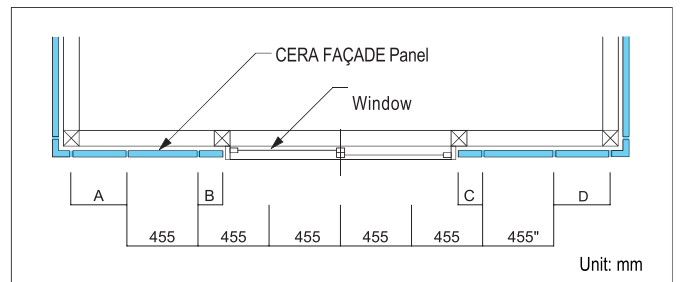

Frame Check

- Stud spacing should be maximum 600 mm or less before installation.

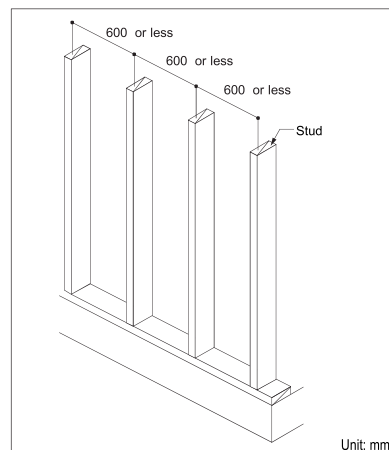

Panels set-out

Center the Joint

The building wall centerline matches a vertical joint.

Example: The building wall length is 7.0m. $7.0\text{m} / 2 \div 0.455\text{m}$ (panel width) = 7.69

The number after the decimal point is 0.5 and above, then choose "Center the Joint" arrangement.

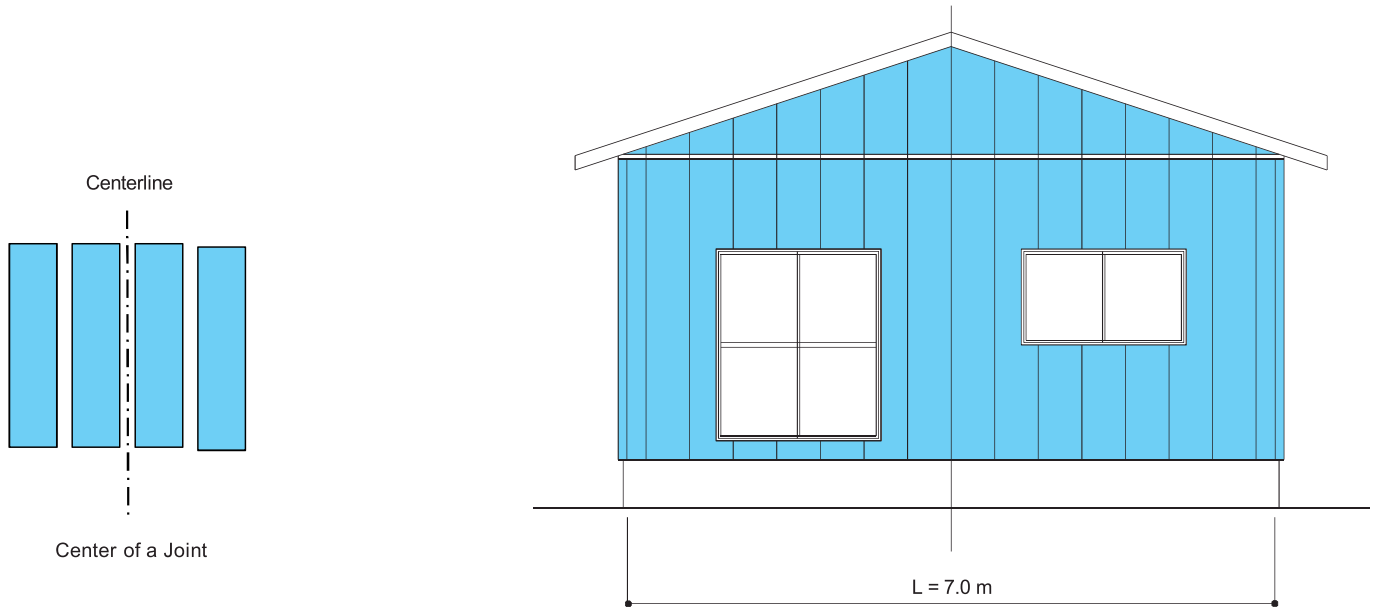

Center the Panel

The building wall centerline matches a vertical joint.

Example: The building wall length is 7.0m. $7.0\text{m} / 2 \div 0.455\text{m}$ (panel width) = 7.69

The number after the decimal point is 0.5 and above, then choose "Center the Joint" arrangement.

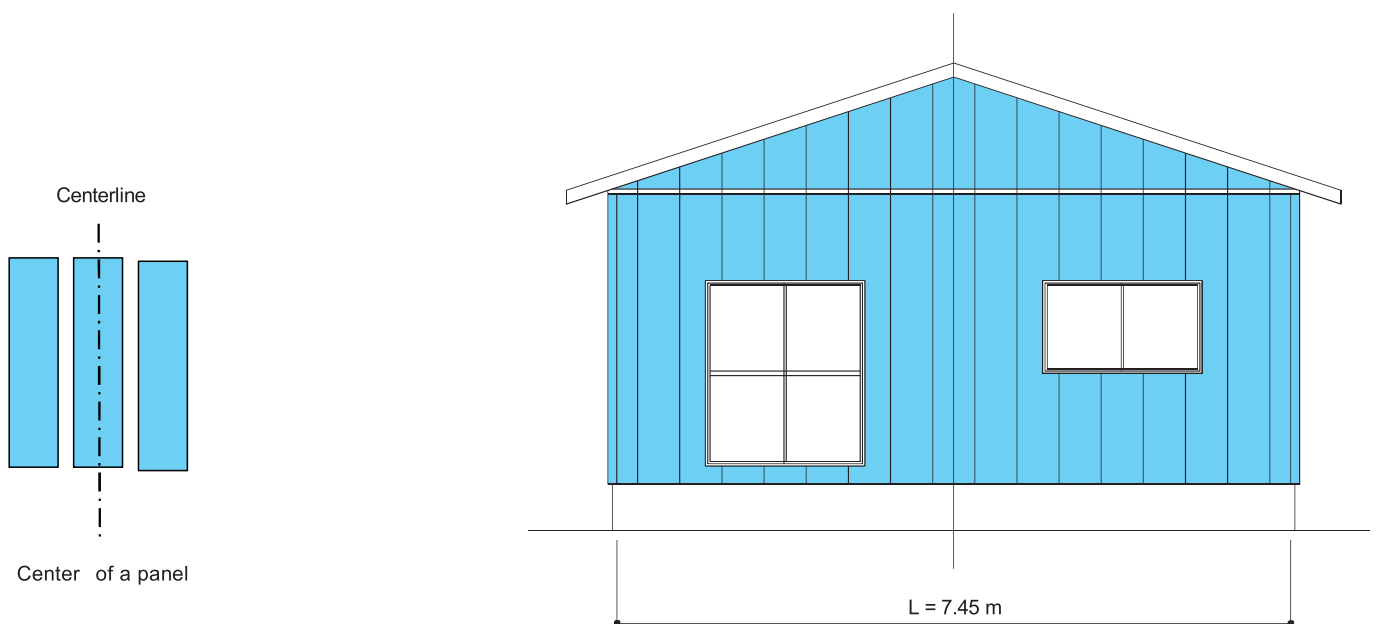

Installation of Sill Flashing

1. Installation of Sill Flashing

- Sill Flashing must cover and protect the sill plate (20mm or more below the plate) from water splash as shown on the figure below.
- The sill flashing width (the side attached to the frame) should be 60mm or more as shown on the diagram below.
- Flashing to be made from material complying with AS/NZS 2728.
- Fasten Sill Flashing (purchase locally) on the substructure (studs or sill plates) with screws or nails at every 600 mm or less interval.
- Level the Sill Flashings with a leveling tool
- The distance between the top of the concrete floor slab and the finished ground level (1 on the diagram below) should meet National Construction Code (NCC) 2019 Volume Two, 3.1.3.3 Surface water drainage (b) slab-on-ground finished slab heights:
 - 50mm or more for paved or concrete areas
 - 100mm or more for low rainfall intensity, sandy, or well-drained areas
 - 150mm or more for any other areas

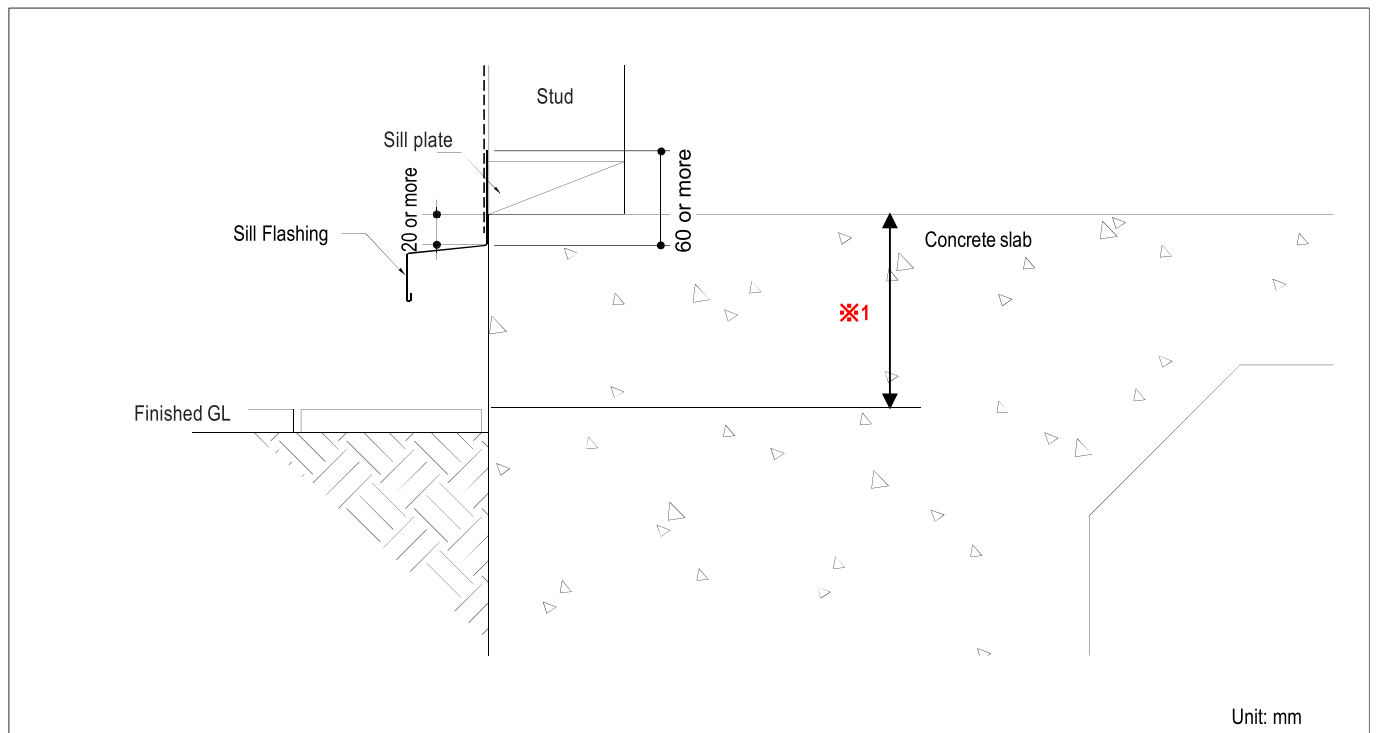
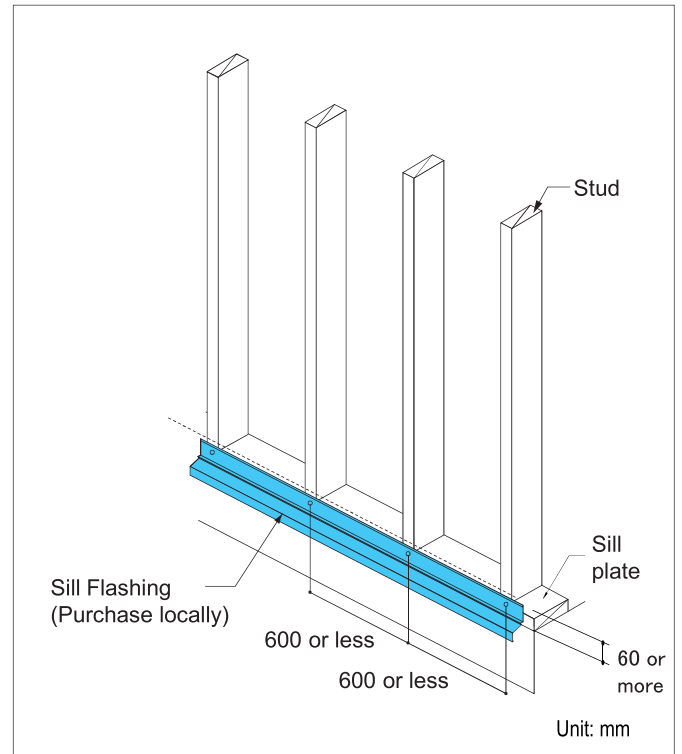

Installation of Sill Flashing

- Overlap the Sill Flashing joints by approx. 50mm.
- Make inside and outside corners as shown on the diagrams right.

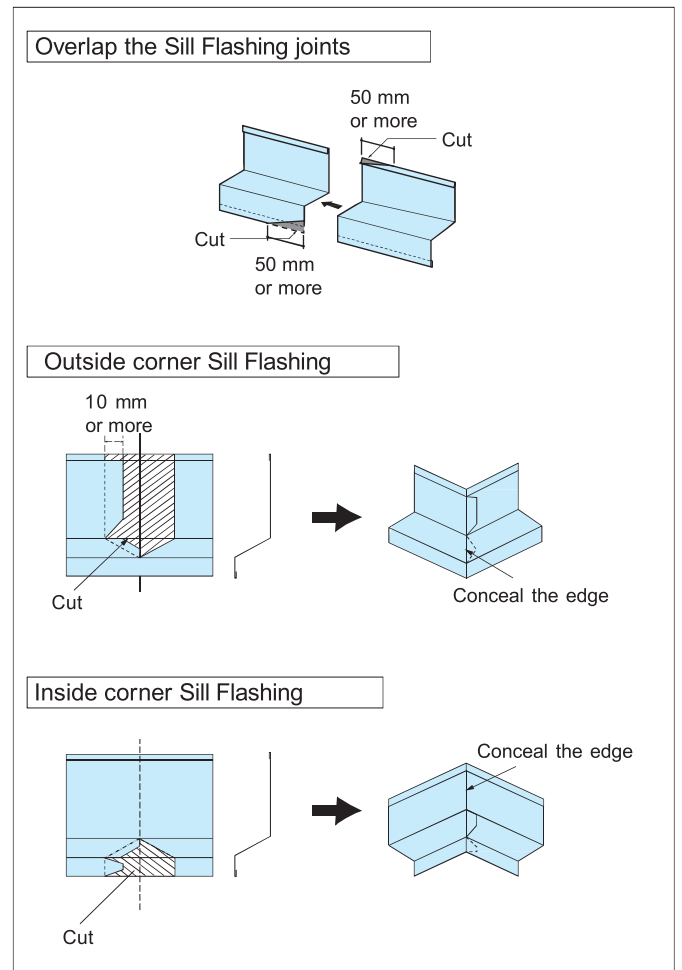

Installation of water resistive breathable sheet (Sarking) with waterproof tape

IMPORTANT: In addition to the instructions here, follow the instructions of the sarking manufacturer.

1. Installation of water resistive breathable sheet (Sarking)

- The selected sarking must comply with and be installed in accordance with AS/NZS 4200 and the sarking manufacturer's instruction prior to the installation of the clips and metal profiles.
- Water resistive breathable sheet (Sarking) shall be applied horizontally from the bottom to the top of the wall.
- Overlap the sarking one span at horizontal laps and 90 mm or more at vertical laps.
- The sarking can be installed continually around external corners. The sarking should be overlapped one span both sides of an internal corner. Refer to the diagram next page. Avoid gaps, tearing, and other defects that degrade waterproofing performance.
- Any tears in the sarking or gaps around service penetrations must be sealed with adhesive tape.
- The selected sarking must be installed taut and rigid so that bulging of bulk thermal insulation into the drainage cavity does not occur.
- Avoid tearing the sarking or letting it sag. If the sarking is torn, insert another layer as shown in the figure below.

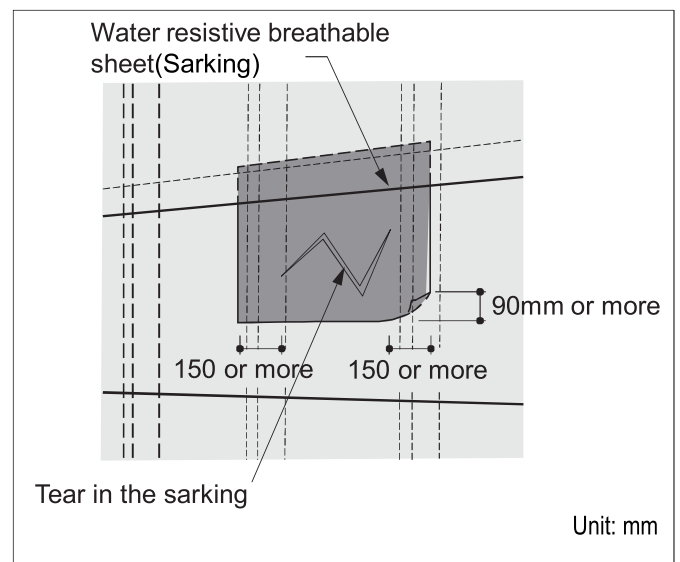
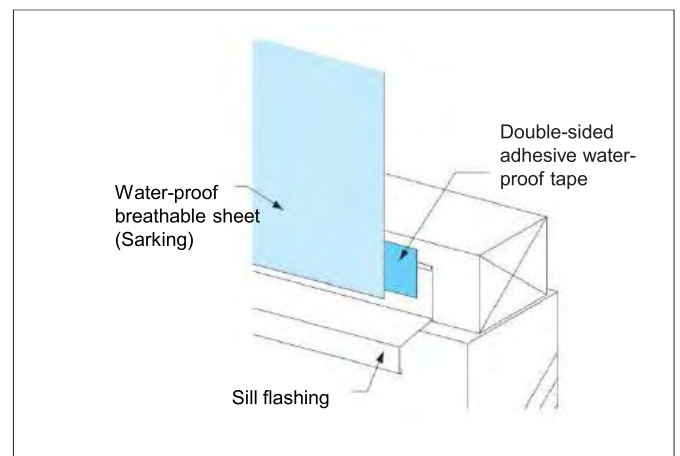
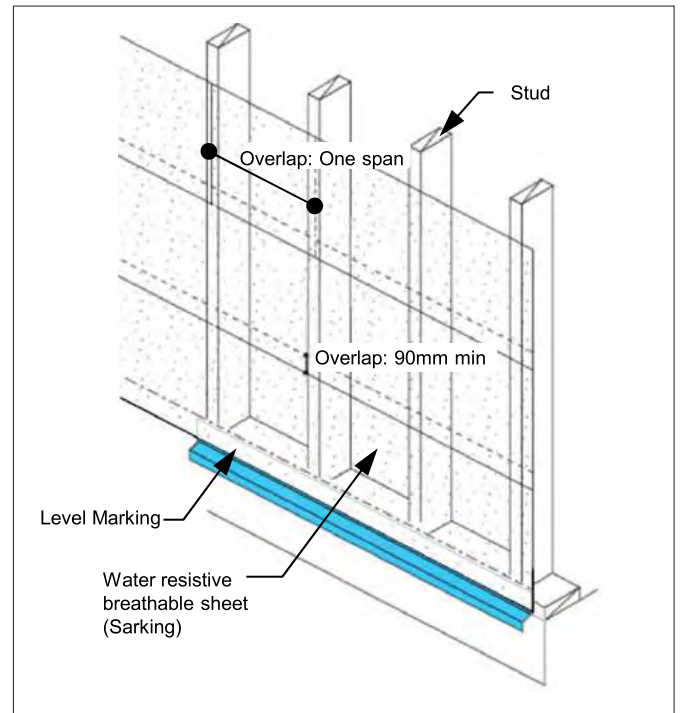

Installation of water resistive breathable sheet (Sarking) with waterproof tape

IMPORTANT: In addition to the instructions here, follow the instructions of the sarking manufacturer.

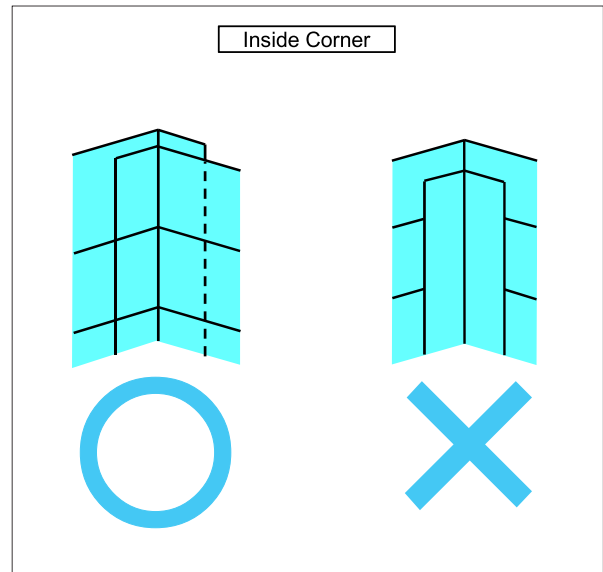
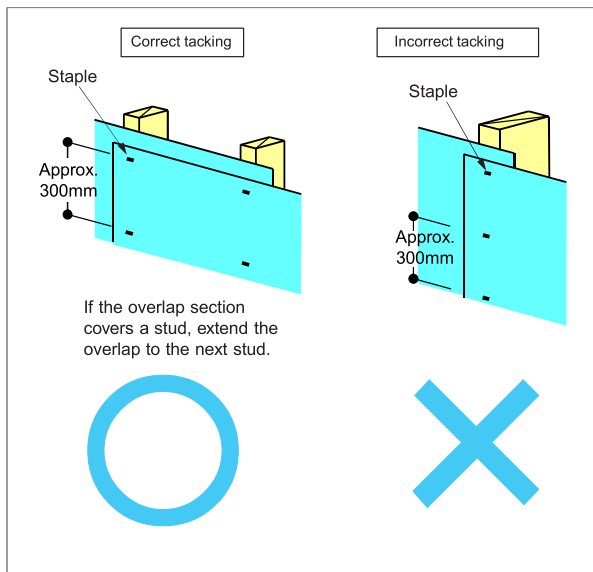

Important notice: The selected sarking must not obstruct cavity airflow. It must be installed taut and rigid against the frame, using staples or double-sided waterproof tape.

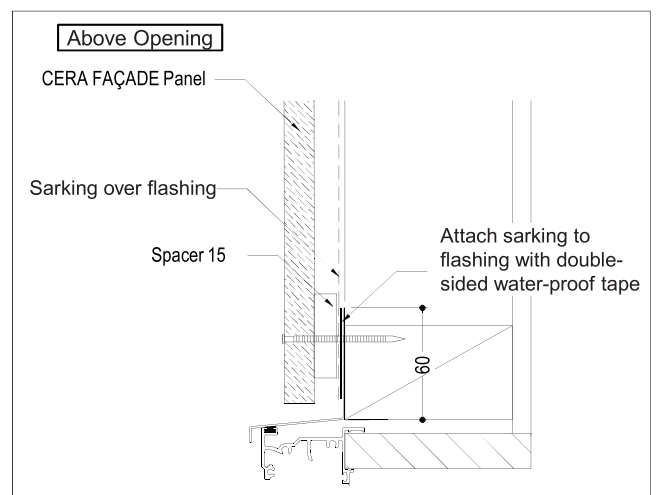
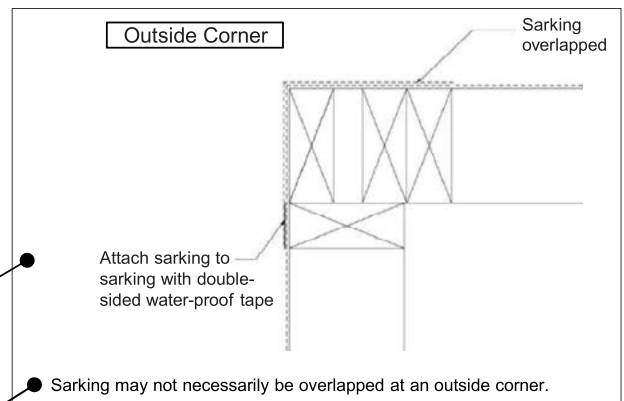
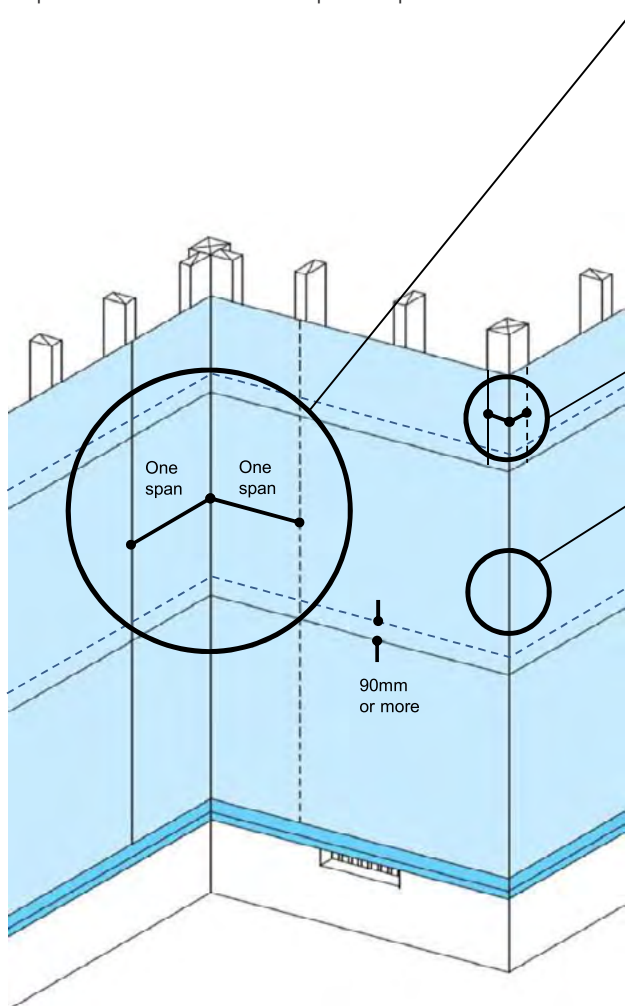

Horizontal Application

1. Points for Installation

- CERA FAÇADE System (Horizontal Application) is for Wind Class N1 to N3.
- Install the CERA FAÇADE panels with panel clips. The additional reinforcing nails need to be used for the corner areas (less than 1,200mm from an external building corner) in the Wind Class N3 as shown on the diagram in Design Criteria, page 14. Insert spacer 15s , predrill pilot holes on the panels and fix the nails near the middle position in the cross-the-width direction of the panel.
- Install the corner cladding with corner clips or install a metal corner instead.
- To fix a panel clip, use a clip screw.

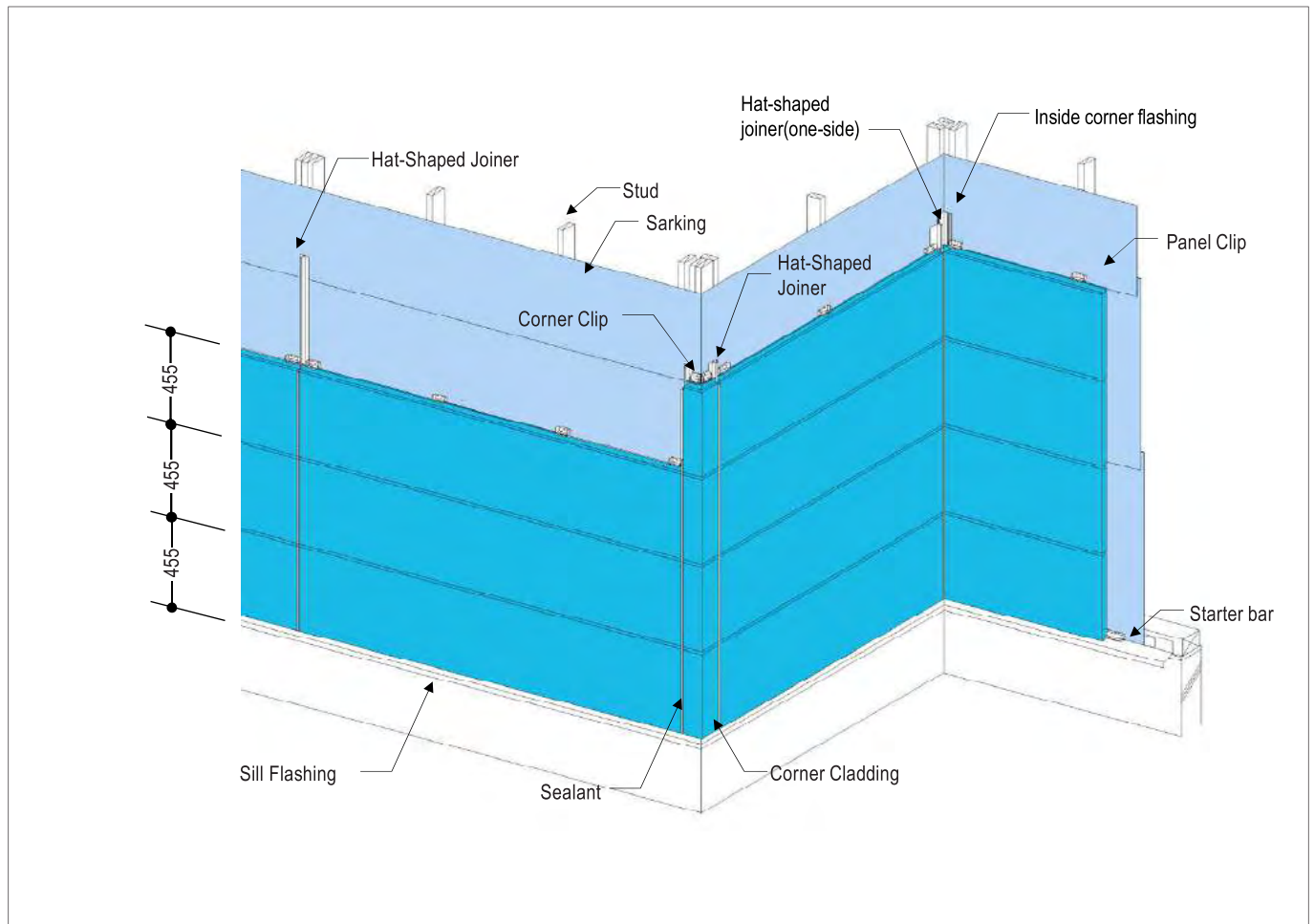

Horizontal Application

2. Starter bar installation along sills

- Starter bars for horizontal application on the sill serve as the base of the CERA FAÇADE panels.
- Mark a level line, 54mm from the sill flashing top as shown on the drawings below for the Starter bars to end up with approximately 10 mm ventilation gap between the bottom of the CERA FAÇADE panels and the sill flashing.
- Fasten the Starter bars securely along the mark with clip screws.
- Maximum distance between the clip screws must not exceed 600 mm.
- Make sure that the starter bars are leveled.

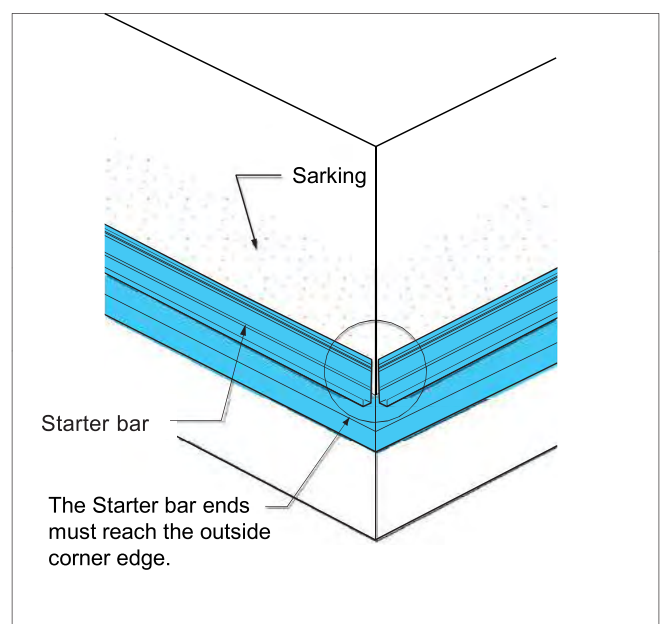
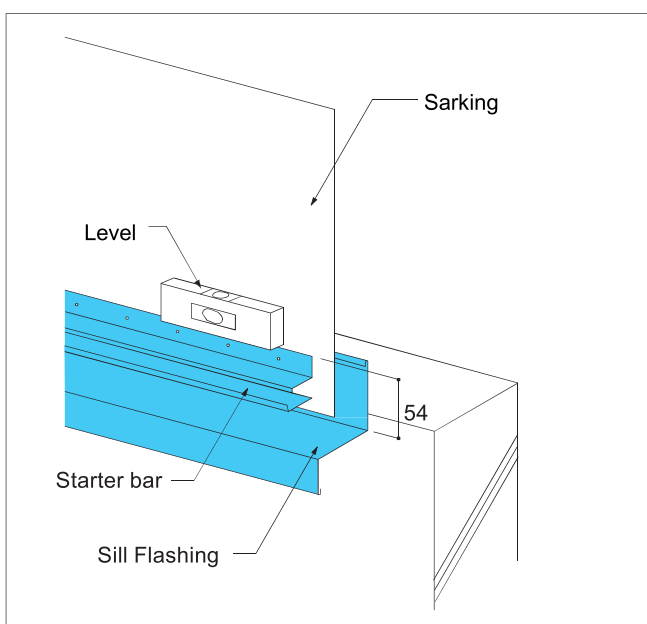
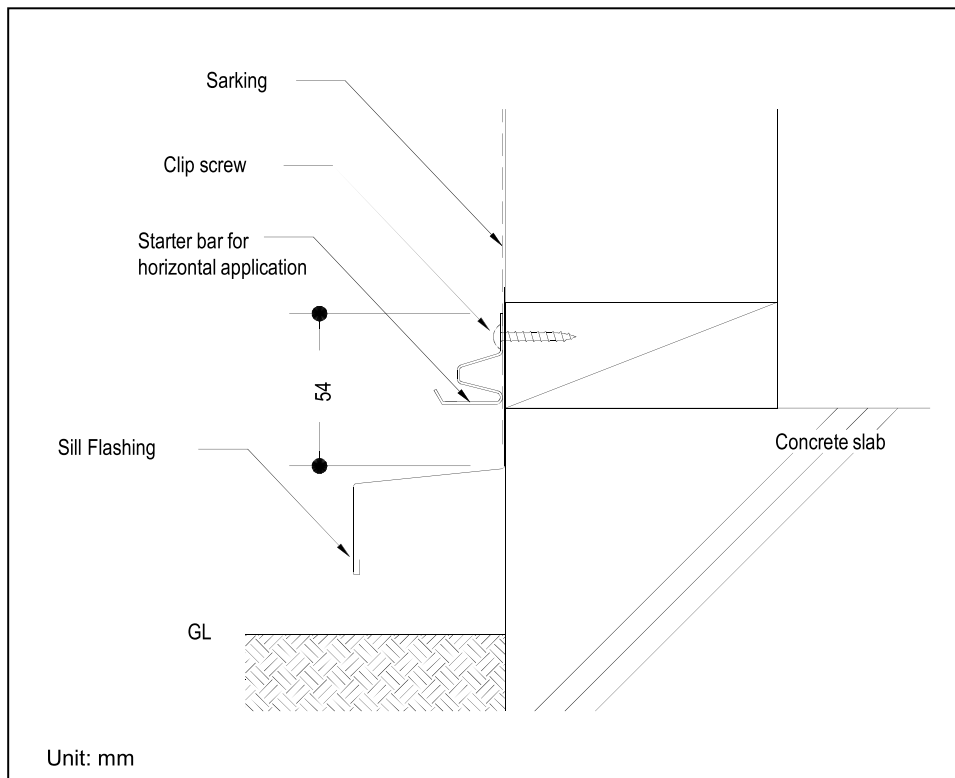

Horizontal Application

3. First CERA FAÇADE panel installation

- Begin installing the first CERA FAÇADE panel from an either side of a joiner. The leading edge of the panel, which is the edge with the concealed groove, should sit squarely on the lower lip of the Starter bar.
- Make sure that the 10 mm ventilation gap between the bottom of the CERA FAÇADE panels and the sill flashing is maintained.
- Make sure that the first panels are leveled.

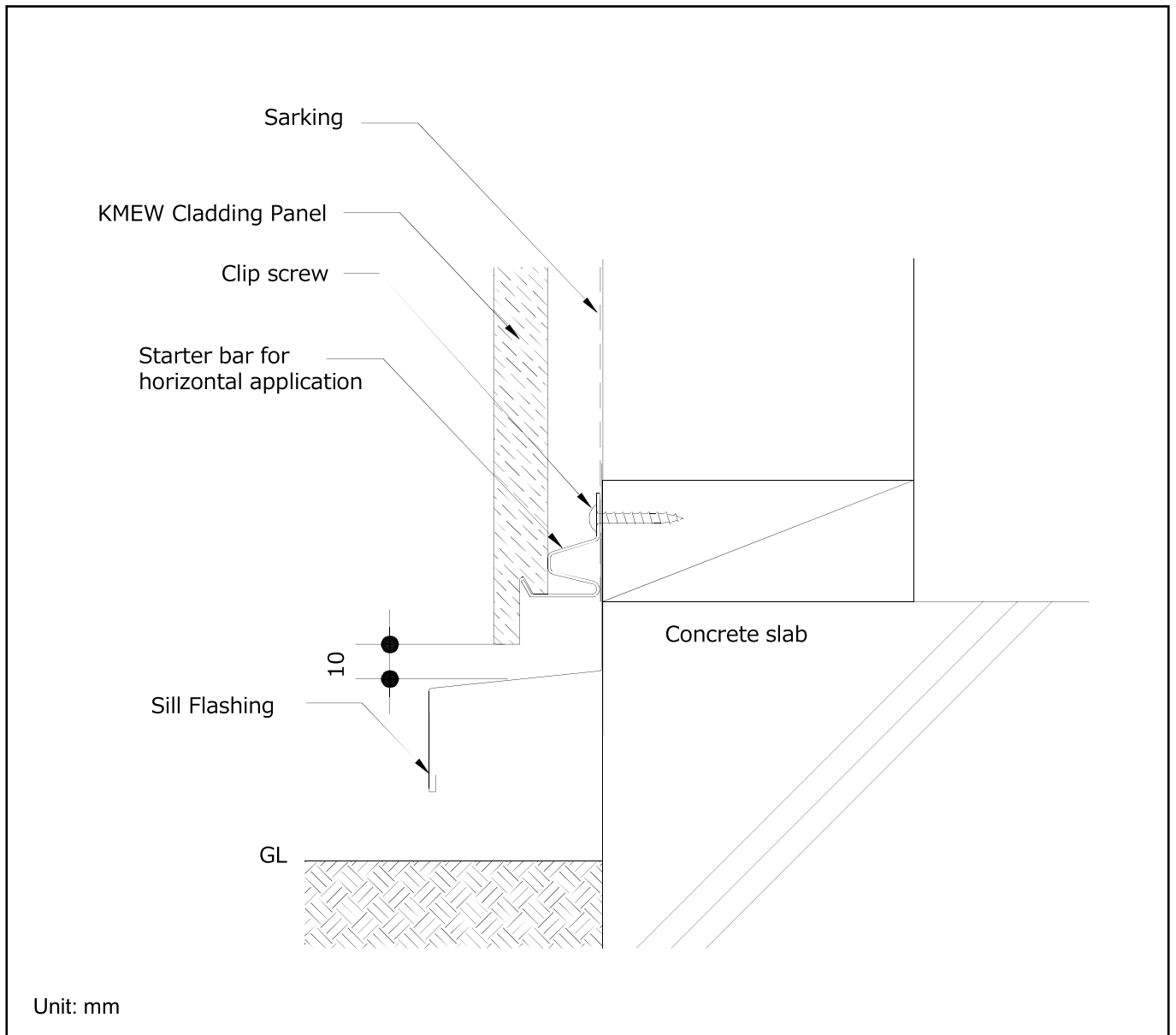
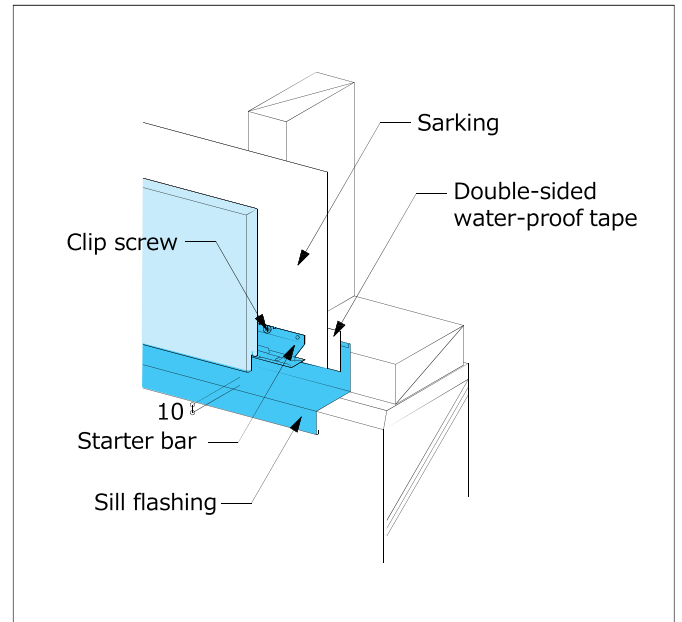

Horizontal Application

4. Clip installation

- Fasten the clips securely on each stud (chalk line) with one clip screw.
- Attach hat-shaped joiner or metal trim at the vertical joint of CERA FAÇADE panels, so that CERA FAÇADE panels butt-up to the hat-shaped joiner or metal trim.
- Maximum distance between clips must not exceed 600 mm, so that one CERA FAÇADE panel (3,030 mm) is required to be fastened with six clips.

A. Sealant Finish

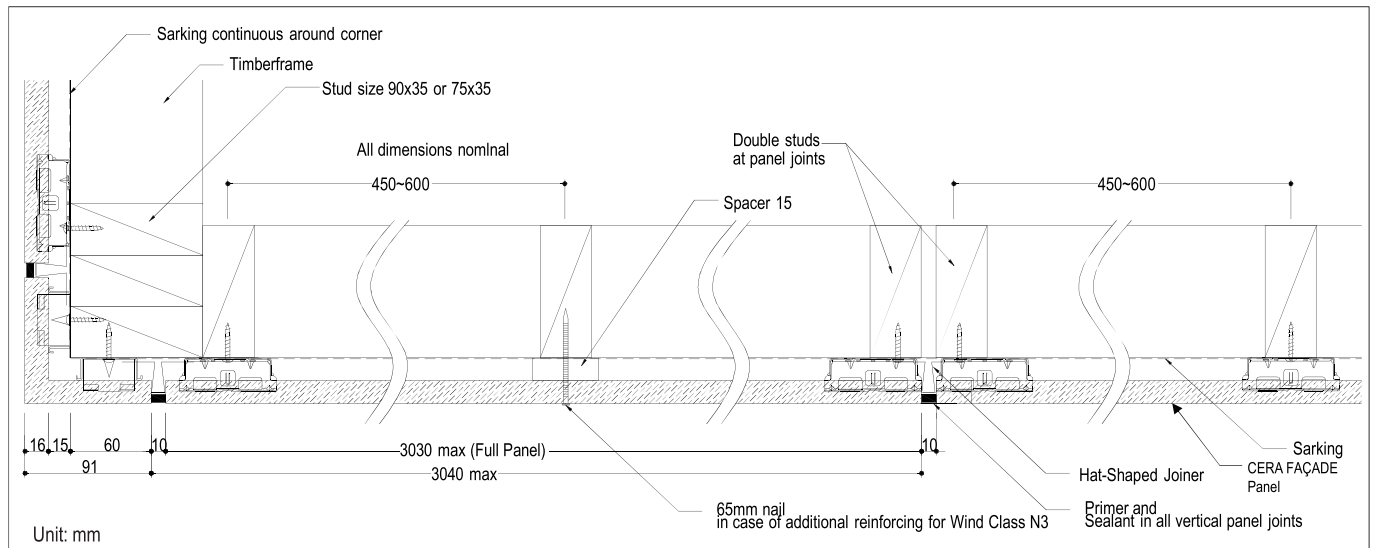

B. Metal Trim (F product only)

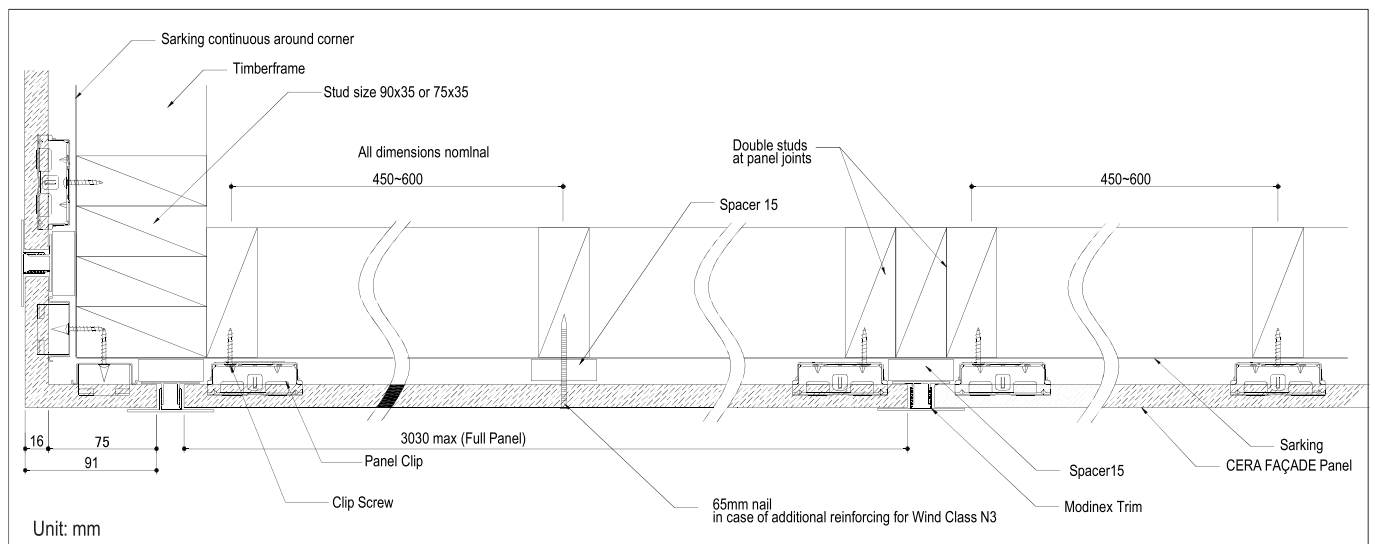

Horizontal Application

5. Vertical Joint

(1) Sealant Finish

- Use the hat-shaped joiners for vertical joint.
- Attach the joiner with nails or screws staggered at approximately 1 meter on center.
- Install panel clips on the panels adjacent to the joiner as shown on the figure left.
- Apply sealant (local purchase) after applying a primer specified by the local manufacturer on the surfaces where the sealant is applied.

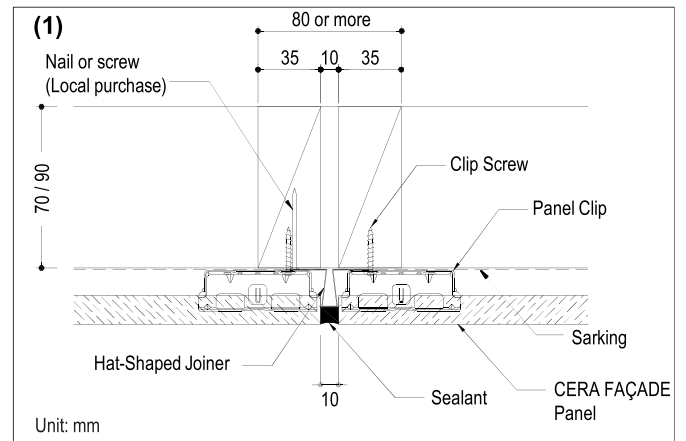

(2) Metal Trim (F product only)

Alternatively, locally produced metal trims may be used as shown on the diagram.

- The metal trims should meet local requirements such as Corrosivity Zone (AS4312). Refer to page 13.
- Refer to Page 16-1 for the recommended metal trim as an example.

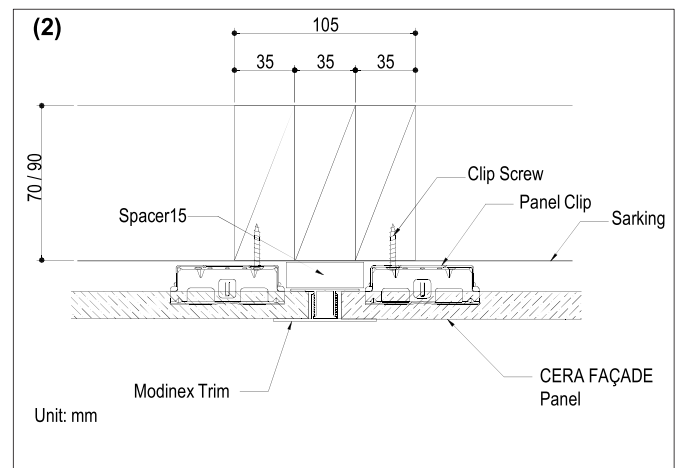

Horizontal Application

6. Outside corner finishing

(1) Metal outside trims

- Metal outside trim to be made from material complying with AS/NZS 2728.
- Attach Spacer 15s to the corner over the water resistive breathable sheet (Sarking) .
- Install metal corner trims onto spacer 15s with nails or screws.
- Insert CERA FAÇADE panels into the metal corner trims and fasten them with panel clips.

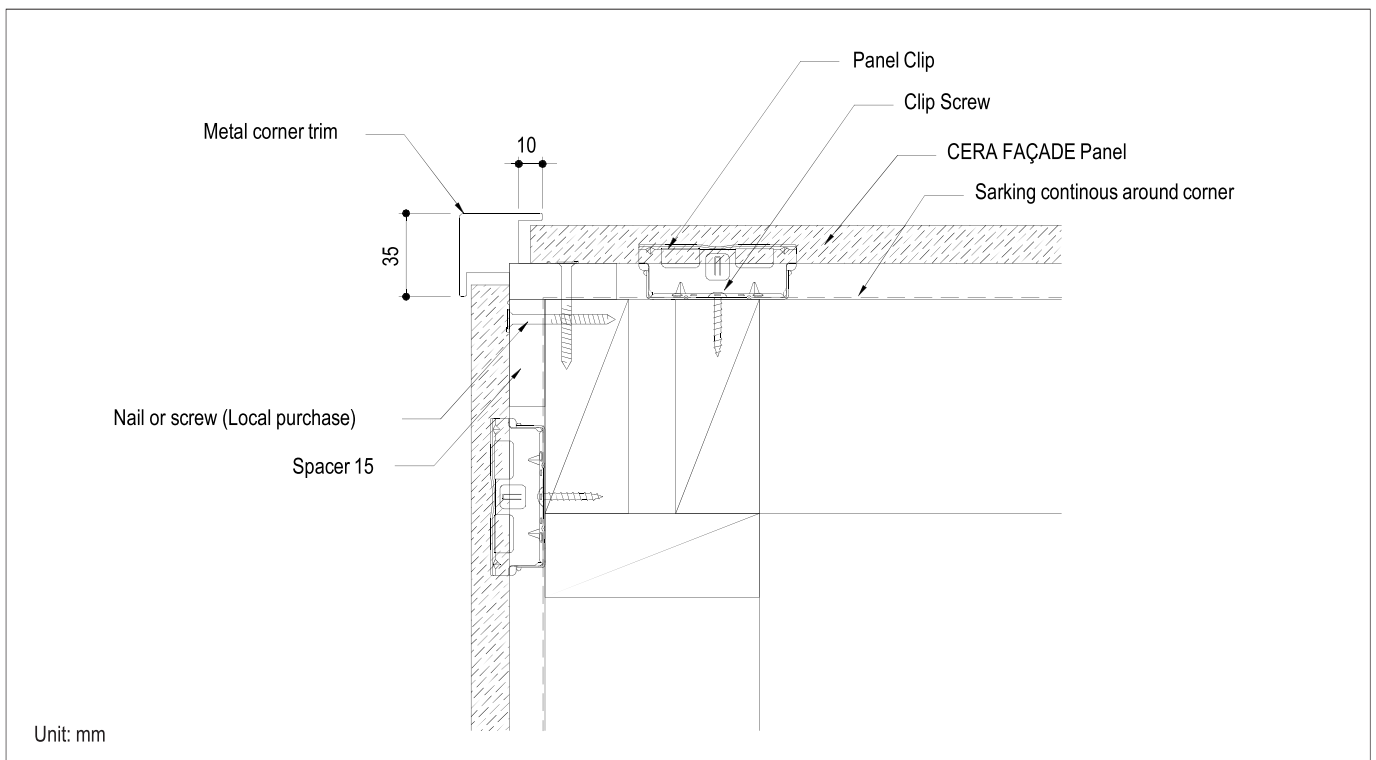
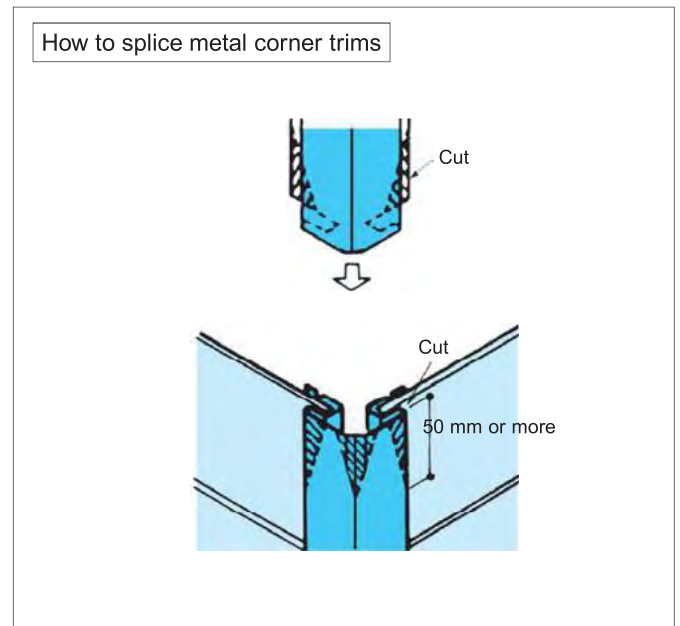

Horizontal Application

(2) Timber corner caps

- Install one-side hat-shaped joiners as shown on the diagram below with nails.
- Attach spacer 15s to the corner over the water resistive breathable sheet (Sarking).
- Install the CERA FAÇADE panels so that they butt-up to the one-side hat-shaped joiner at the corner.
- Apply sealant in the joint. Apply sealant (local purchase) after applying a primer specified by the local manufacturer on the surfaces where the sealant is applied.
- Drill pilot holes (approx. 2 mm diameter) in the timber corner caps and CERA FAÇADE panels with 400 mm pitch, and then nail on the corner caps.
- Corner caps should be securely fastened on the stud, not on CERA FAÇADE panels.

Very Important!

Caution

Without drill pilot holes in CERA FAÇADE panels, CERA FAÇADE panels will be broken.

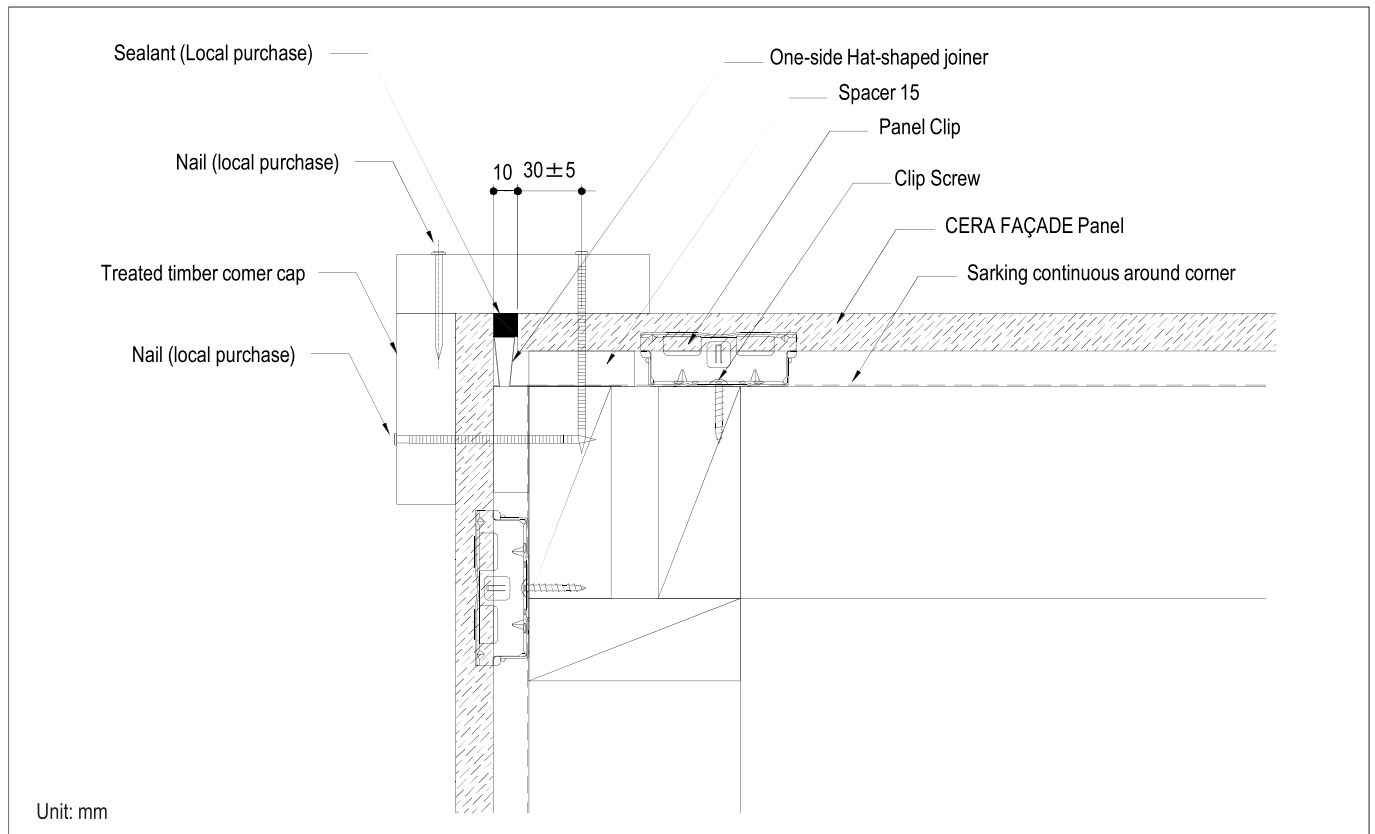

Horizontal Application

(3) Corner cladding — made of matching materials

- Install corner cladding with corner clip.
- Attach hat-shaped joiners or metal trims adjacent to the corner claddings with nails or screws. In case of metal trims, use spacer15.
- Ensure that the CERA FAÇADE panels and the corner claddings are leveled every time a row is finished.
- Apply sealant in the joints. Apply sealant (local purchase) after applying a primer specified by the local manufacturer on the surfaces where the sealant is applied.

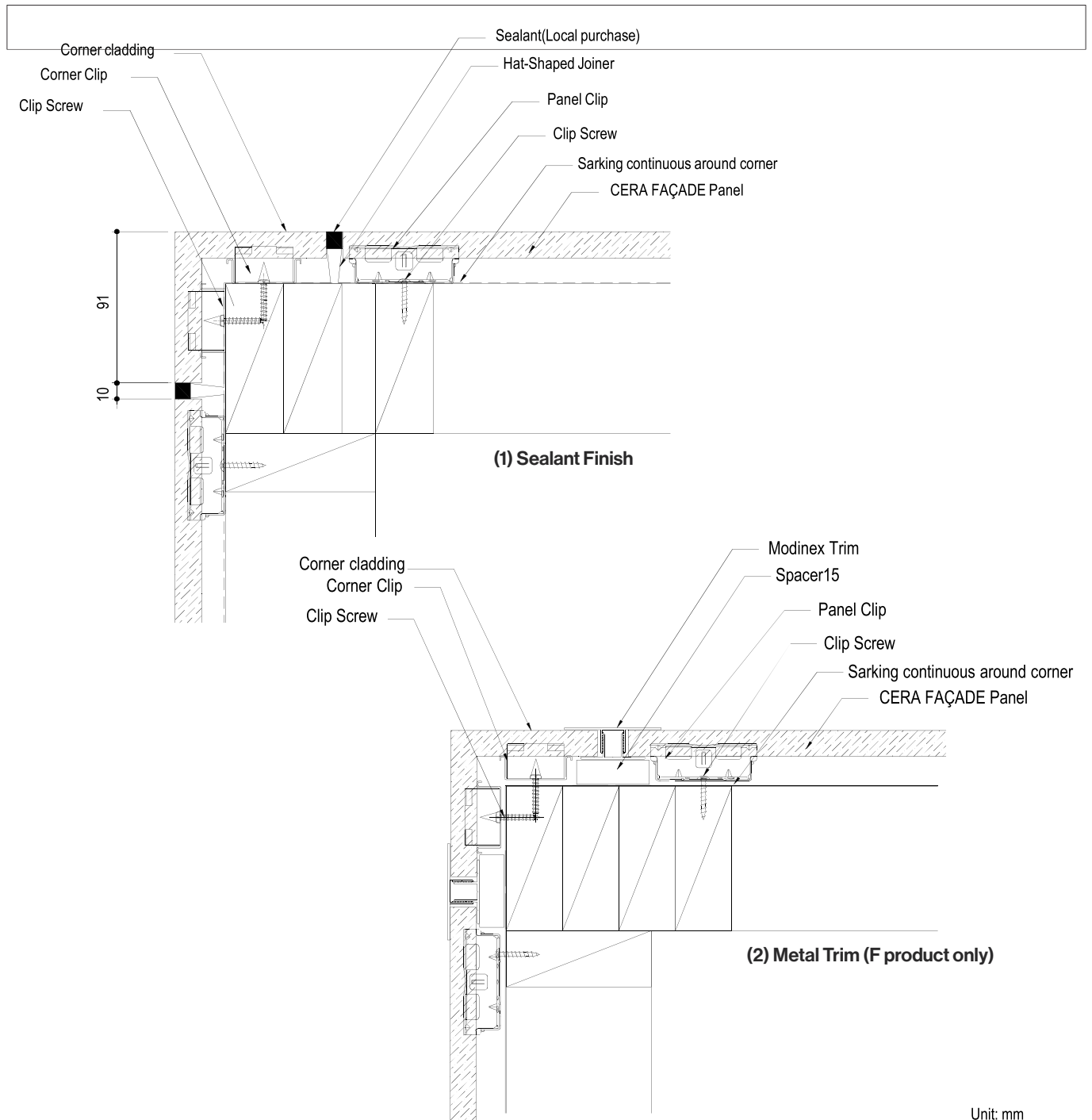

Horizontal Application

7. Inside corner finishing

(1) Sealant finish

- Attach inside corner flashings to inside corners.
- After completion of panel installation on a wall, fasten hat-shaped joiners (one-side) at the corner.
- Install the CERA FAÇADE panels on the other wall so that they butt-up to the hat-shaped joiners (one-side).
- Apply sealant in the joints. Apply sealant (local purchase) after applying a primer specified by the local manufacturer on the surfaces where the sealant is applied.

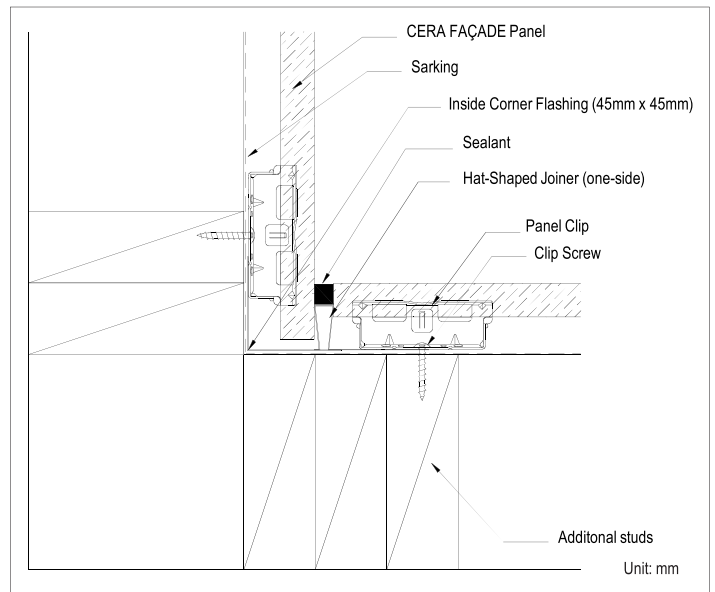

(2) Metal inside trim (F product only)

- Spacer thickness should be adjusted for the metal inside trim (locally produced) so that unevenness is within the 2mm requirement.
- The metal trims should meet local requirements such as Corrosivity Zone (AS4312). Refer to page 13.

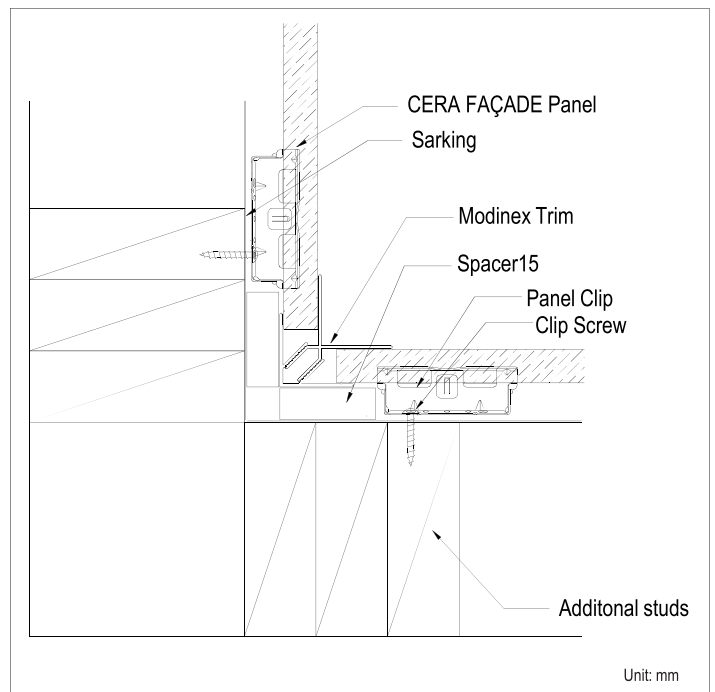

Horizontal Application

8. Under eaves

(1) Eave liner

- Attach spacer 15s on the sarking at the stud positions as shown on the diagram below.
- Pre-drilling pilot holes in the CERA FAÇADE panels at the locations where the spacers have been set, and fasten the panels with 65mm nails to the studs.
- Make sure that air from cavity is ventilated out through the eave or attic/roof ventilation system.
- Provide sufficient protection on the CERA FAÇADE panels before application of paint on the eave liner and eave sheet.

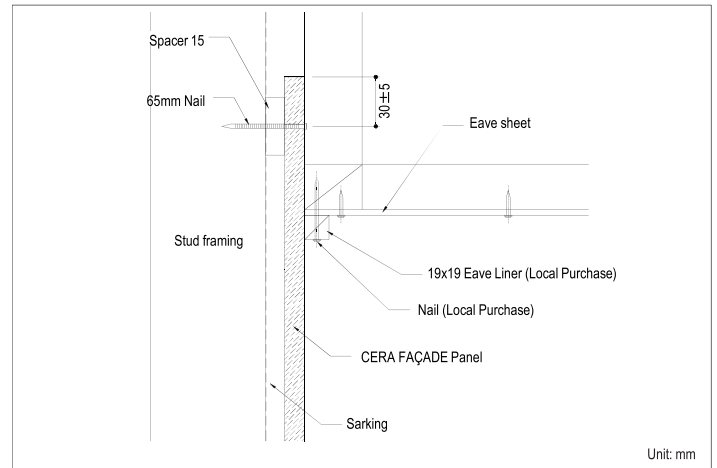

(2) Ventilating Soffit Flashing

- Attach spacer 15s on sarking at studs and fasten soffit flashing with screws onto the studs.
- Install the ventilating soffit flashing right under the soffit.
- Insert CERA FAÇADE panel into the ventilating soffit flashing so to have cut edges of the panels are covered.
- Pre-drill pilot holes on the panel avoiding the ventilation soffit flashing, and fasten the panel with 65mm nails.

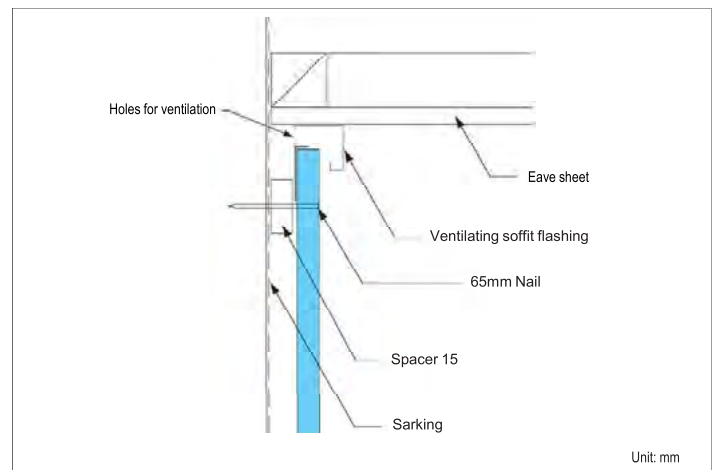

Horizontal Application

9-1. Opening (Permanently-set window)

<Above opening>

- Install a metal flashing above the window, and then cover the metal flashing with water resistive building sheet (Sarking).
- Metal flashing should have 15 degree slope and a 60 mm upstand as shown on the diagram right.
- Leave approximately 10 mm of space from the metal flashing to install a CERA FAÇADE panel.
- To fix the CERA FAÇADE panel above the opening, use the spacer 15 to provide 30 ± 5 mm of space for edge finishing, predrill pilot holes (of approximately 2 mm in diameter), and then fix the panel to the studs with 65mm nails.

<Under opening>

- The CERA FAÇADE panel cut edges at the window frame are to have sealant applied.
- To fix the CERA FAÇADE panel under the opening, use the spacer 15 to provide 30 ± 5 mm of space for edge finishing, predrill pilot holes (of approximately 2 mm in diameter), and then fix the panel to the studs with 65mm nails.
- At the corners under the opening, clips cannot be fastened because there is no shiplap. Attach spacer 15s and fasten the panel with nails. Fasten the clips next to the opening above it.
- Apply sealant (local purchase) after applying a primer specified by the local manufacturer on the surfaces where the sealant is applied.

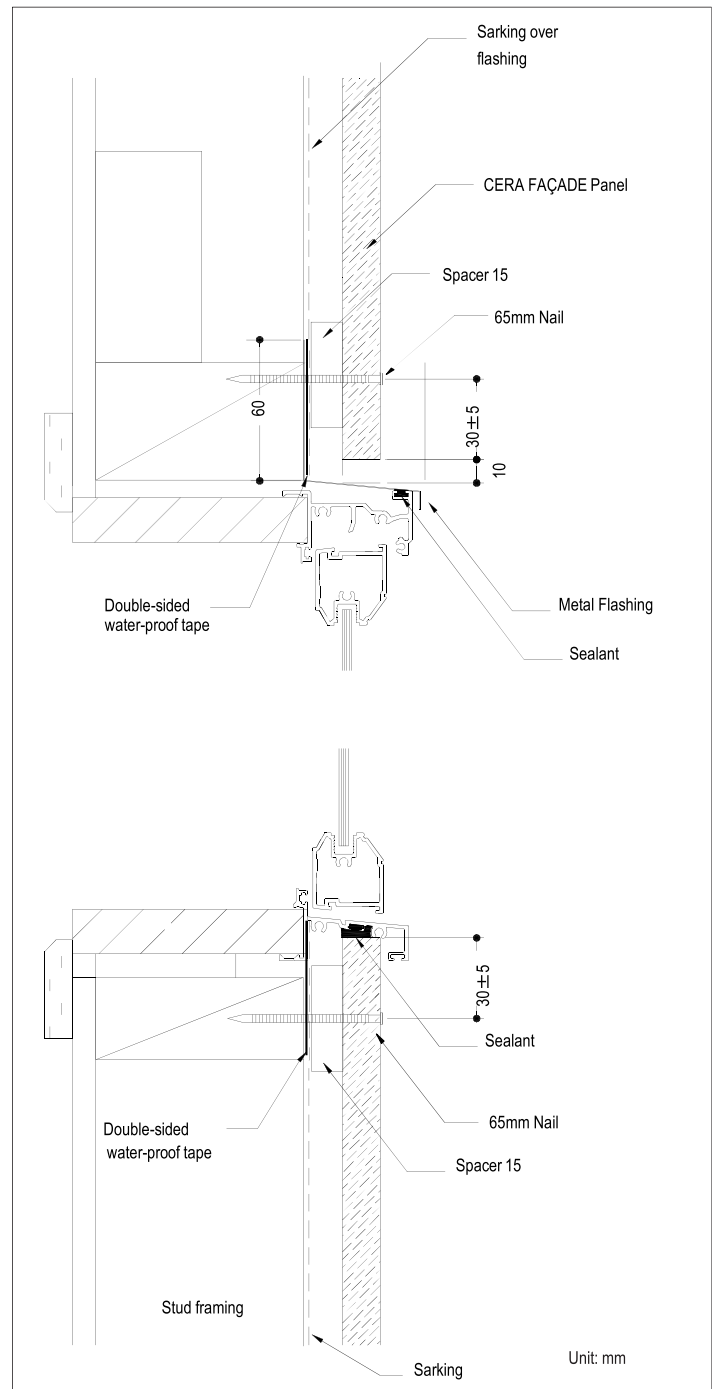

Horizontal Application

9-1. Opening (Permanently-set window)

<Side opening>

- Sarking must be firmly fixed around the opening with double-sided waterproof tape.
- Install a CERA FAÇADE panel to butt-up to the opening frame with panel clips.
- Provide sealant between the CERA FAÇADE panels and the frame of opening with backup materials. Apply sealant (local purchase) after applying a primer specified by the local manufacturer on the surfaces where the sealant is applied.

For the solid core product (16mm, CERA FAÇADE F), Water-Sealing Materials (WSM) is not required to the metal flashing. However, appropriate waterproofing methods should be applied to joints at window/door frames to minimize water in to the cavity as a local common practice as necessary, for which KMEW is not responsible.

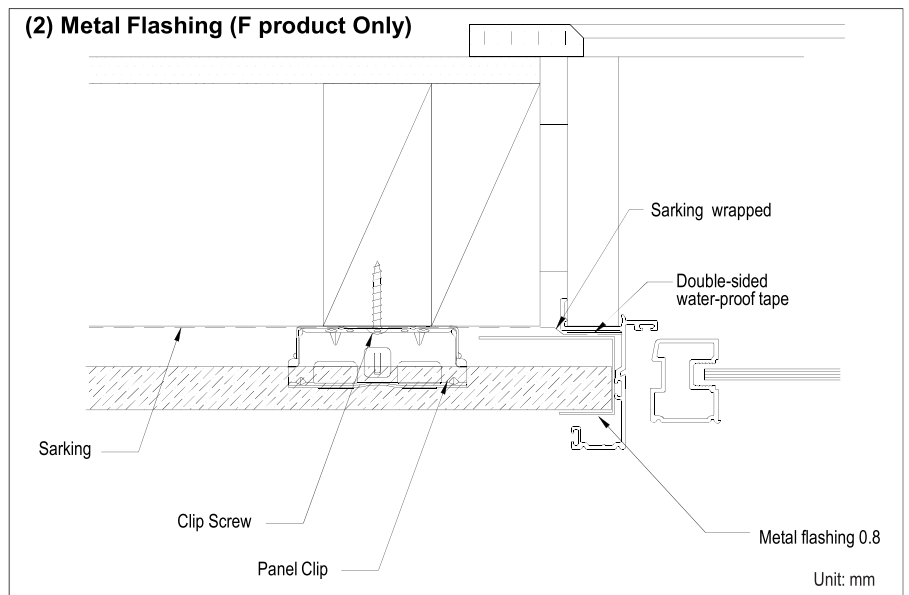
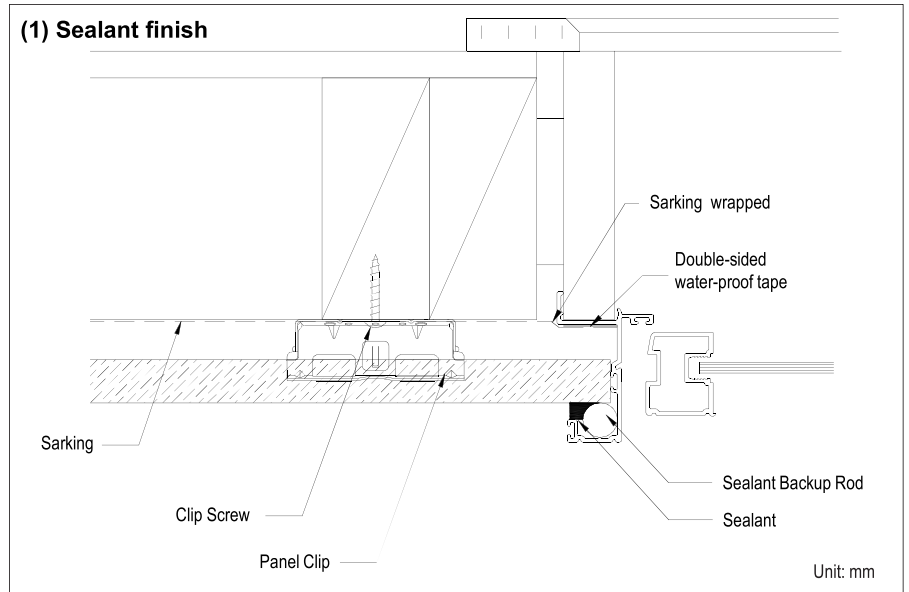

Horizontal Application

9-2. Opening (Sliding window)

<Above opening>

- Install a metal flashing above the window, and then cover the metal flashing with water resistive building sheet (Sarking).
- Metal flashing should have 15 degree slope and a 60 mm upstand as shown on the diagram right.
- Leave approximately 10 mm of space from the metal flashing to install a CERA FAÇADE panel.
- To fix the CERA FAÇADE panel above the opening, use the spacer 15 to provide 30 ± 5 mm of space for edge finishing, predrill pilot holes (of approximately 2 mm in diameter), and then fix the panel to the studs with 65mm nails.

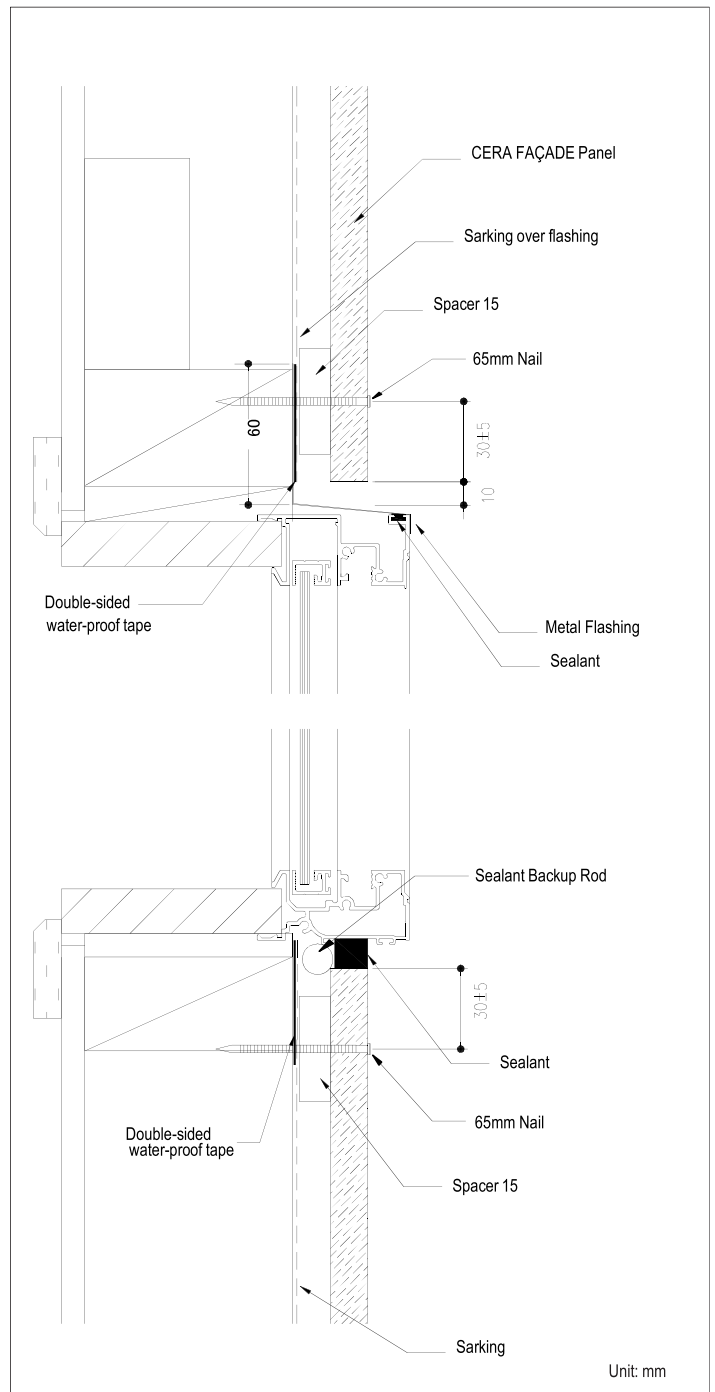

<Under opening>

- Seal space between the CERA FAÇADE panel and the opening.
- To fix the CERA FAÇADE panel under the opening, use the spacer 15 to provide 30 ± 5 mm of space for edge finishing, predrill pilot holes (of approximately 2 mm in diameter), and then fix the panel to the studs with 65mm nails.
- At the corners under the opening, clips cannot be fastened because there is no shiplap. Attach spacer 15s and fasten the panel with nails. Fasten the clips next to the opening above it.
- Apply sealant (local purchase) after applying a primer specified by the local manufacturer on the surfaces where the sealant is applied.

Horizontal Application

9-2. Opening (Sliding window)

<Side opening>

- Sarking must be firmly fixed around the opening with double-sided waterproof tape.
- Install hat-shaped joiners (one side) adjacent to the window frame as shown on the diagram below.
- Install a CERA FAÇADE panel to butt-up to the hat-shaped joiner (one side) with panel clips.
- Leave approximately 10 mm of space from the opening to install a CERA FAÇADE panel, and then seal the said space. Apply sealant (local purchase) after applying a primer specified by the local manufacturer on the surface where the sealant is applied.

For the solid core product (16mm, CERA FAÇADE F), Water-Sealing Materials (WSM) is not required to the metal flashing. However, appropriate waterproofing methods should be applied to joints at window/door frames to minimize water in to the cavity as a local common practice as necessary, for which KMEW is not responsible.

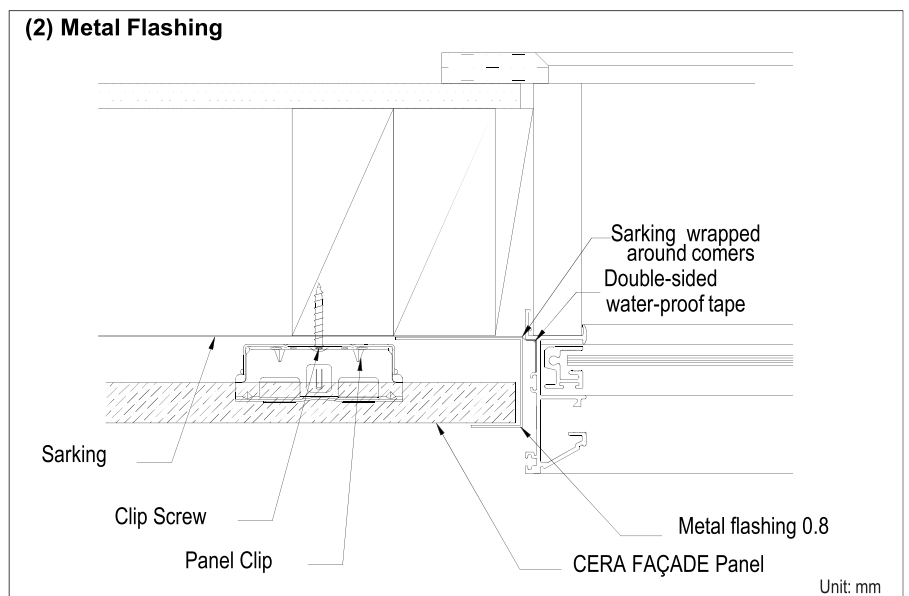
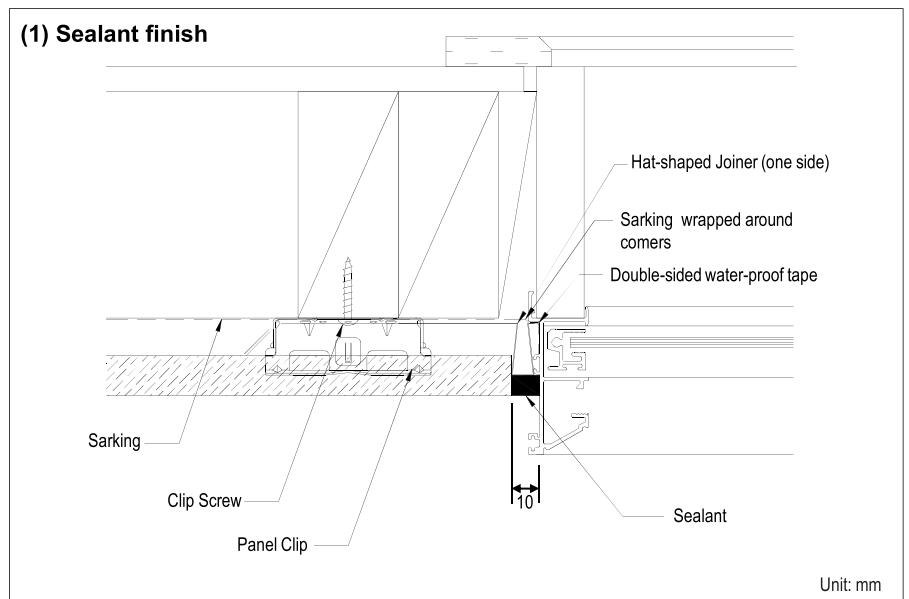

Horizontal Application

10. Intersection with roof

- CERA FAÇADE Panel and roof flashing should be installed with a gap of about 10 to 15 mm. (To prevent capillary phenomenon, maintain air intake, drain condensation, and absorb displacement due to structural load)
- Waterproof breathable building paper (Sarking) should be overlapped on the roof flashing as shown below.
- Attach the sarking to the roof flashing with a double-sided water-proof tape to prevent the paper from rattling by wind and from leaping up in the air cavity. However, the double-sided water proof tape is not required in case that the sarking is stuck with horizontal furring strips, or starter bars.
- In case of horizontal furring strips (15mm thick, pressure treated) to be used, place a 30mm or more gap every 2000mm or less of horizontal furring strips for air circulation.
- The starter bars for horizontal application might be used only for the ridge sides. If the starter bars are used, then the 65mm nails and furring strips may not be used.
- For the slope sides, or in case that the starter bars for horizontal application cannot be used for the ridge sides, fasten the panel with furring strip and 65mm nails. Spacer15s can be used instead of the furring strips.

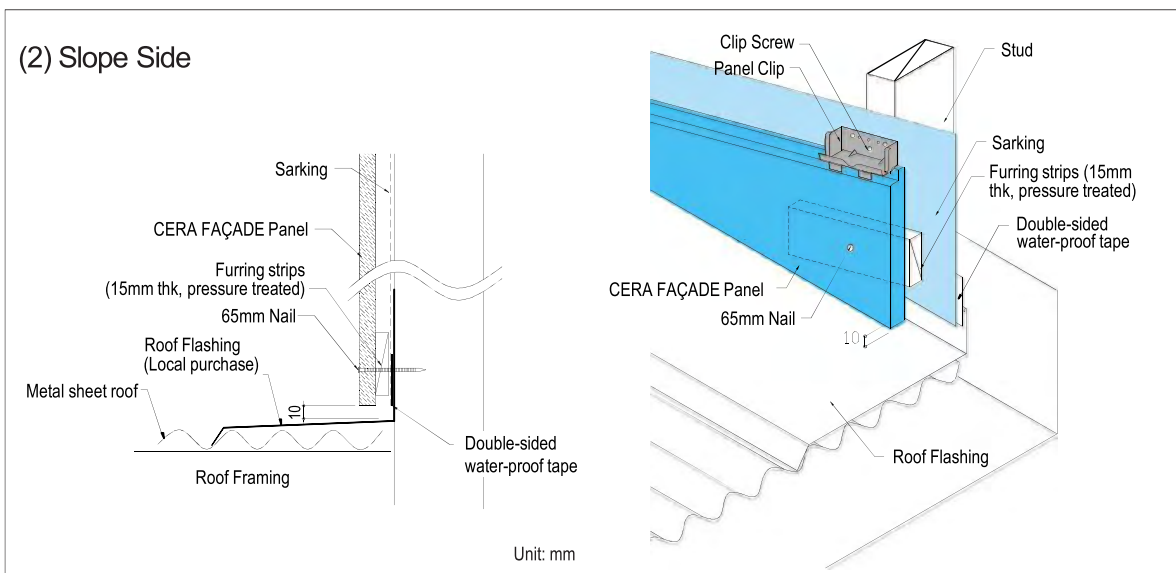
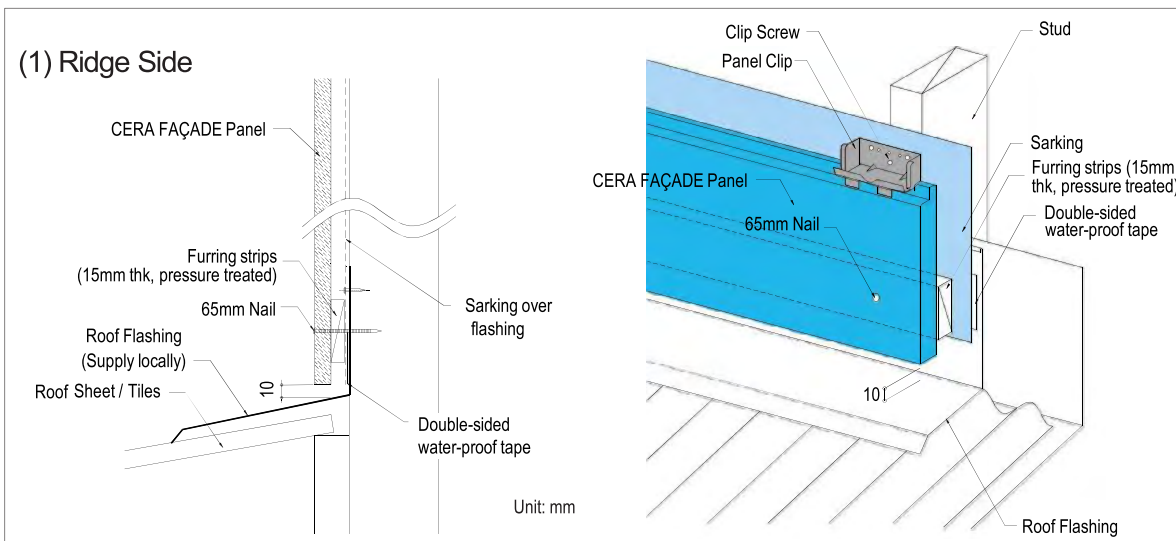
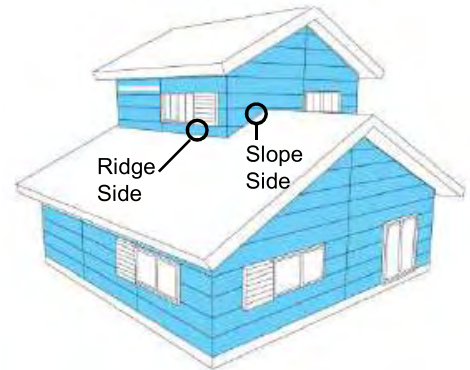

Vertical Application

1. Points for Installation

- CERAFAÇADE System (Vertical Application) is for Wind Class N1 to N3.
- Install the CERA FAÇADE panels with panel clips. The additional reinforcing nails need to be used for the corner areas (less than 1,200mm from an external building corner) in the Wind Class N3 as shown on the diagram in Design Criteria, page 14. Insert clip 15s and predrill pilot holes and fix the nails near the middle positions in the cross-the-width direction of the panels.
- Install the corner cladding with corner clips or install a metal corner trims instead.
- To fix a panel clip, use a clip screw.

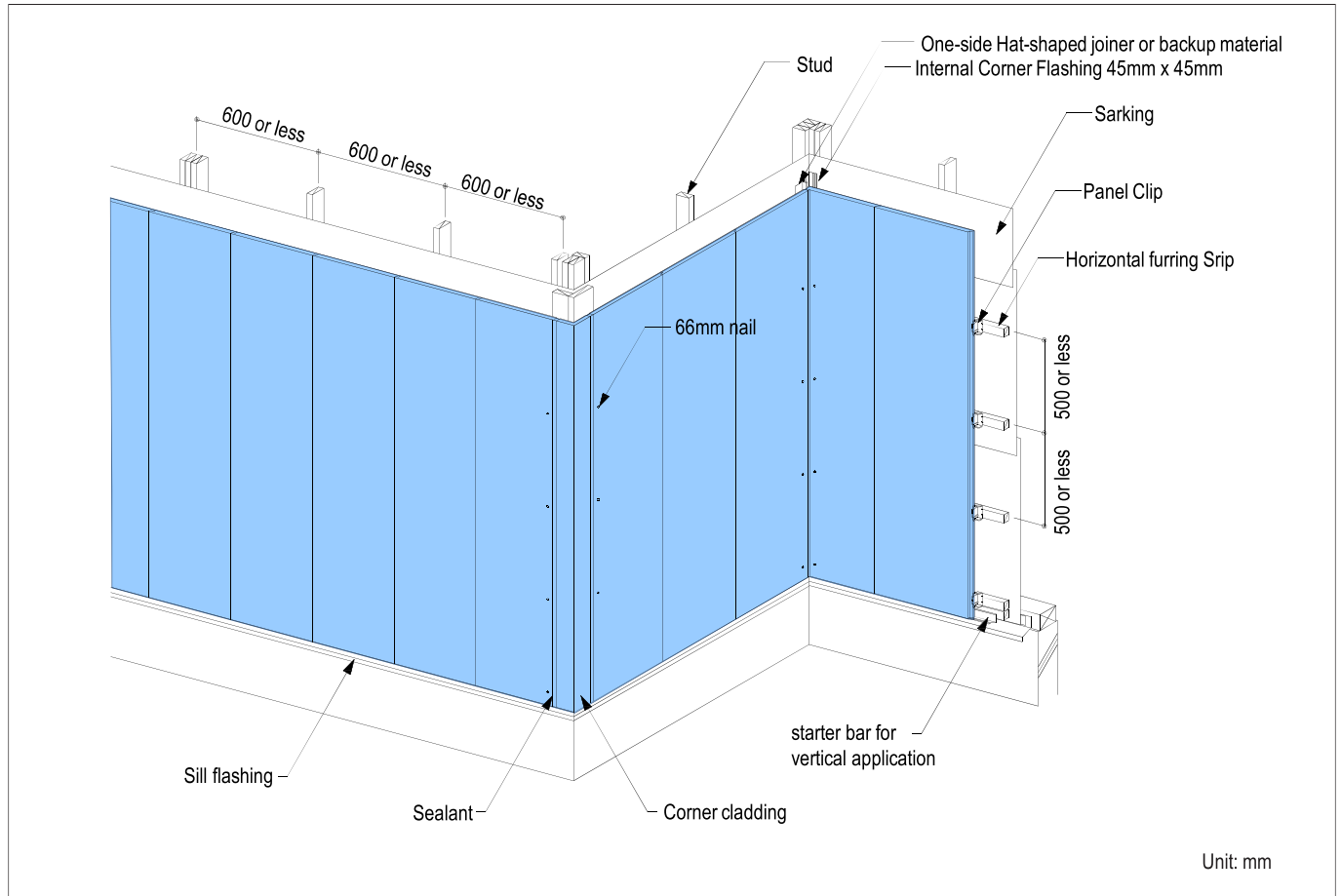

Pre-cautions for vertical application:

- Make sure to use starter bars for vertical application to fully support the CERAFAÇADE Panels and ensure that the starter bars are fastened onto the structural framing.
- The lowest panel clip installed on each vertical CERA FAÇADE Panel must be secured as close to the starter bars as possible. If it is not possible to install a panel clip right above starter bar, then insert a spacer 15 and fasten the panel with a 65mm nail instead.

Vertical Application

2. Install horizontal furring strips

- The horizontal furring strips must have a minimum thickness of 30mm. The recommended size of the furring strip is 35mm thickness by 42mm width.
- At the sill, double 42mm width or a 90mm width strips should be used for the starter bars and the first panel clips.
- The interval of horizontal furring strips must be 500mm or less.
- A gap (30mm or more) must be provided every 2000mm or less on the horizontal furring strips so as to maintain airflow in the cavity as shown on the diagrams below.
- At outside corners, vertical furring strips should be installed. The recommended size of the furring strip is 35mm thickness by 70mm width.

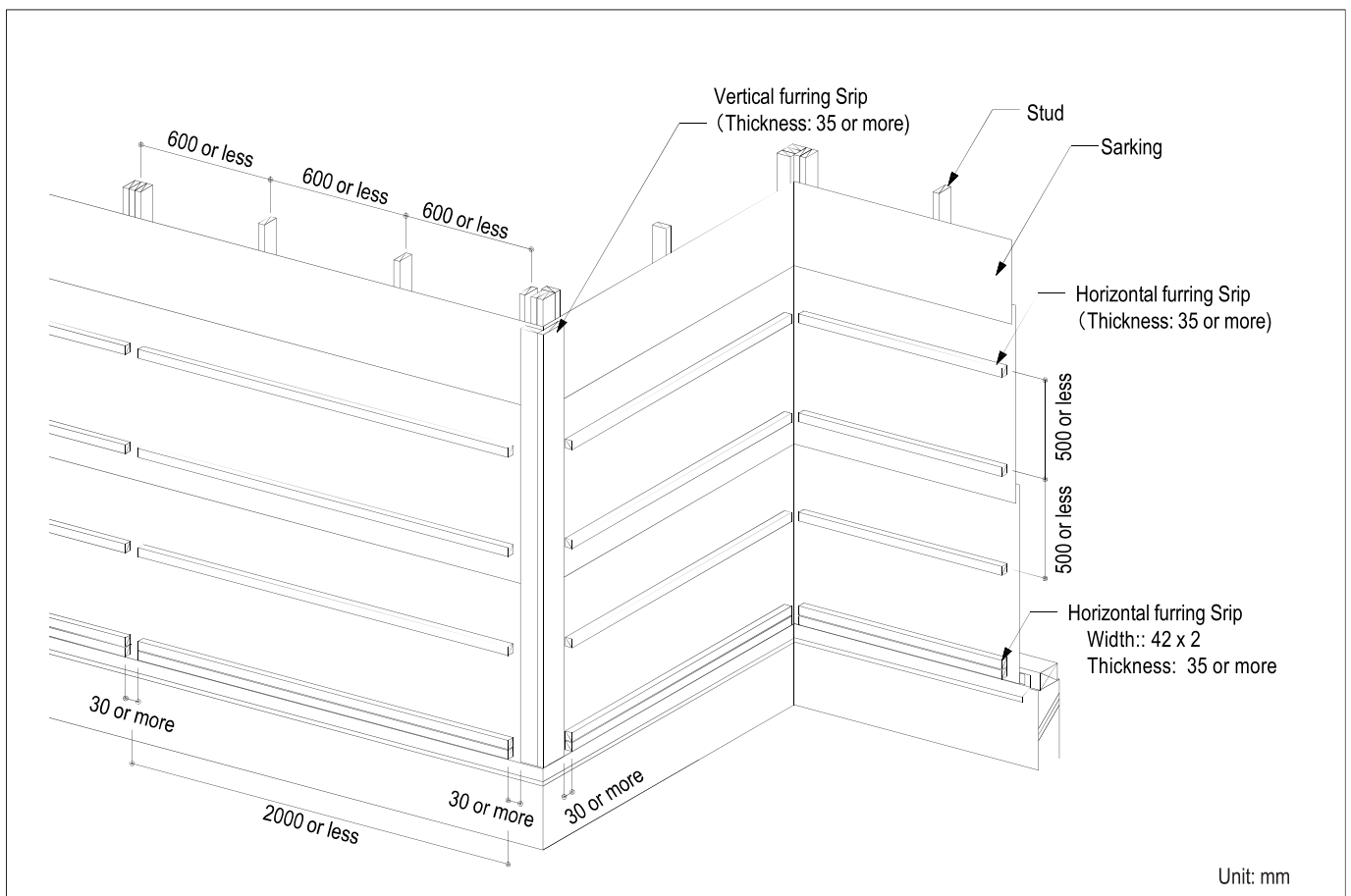

- An example of horizontal furring strip layout

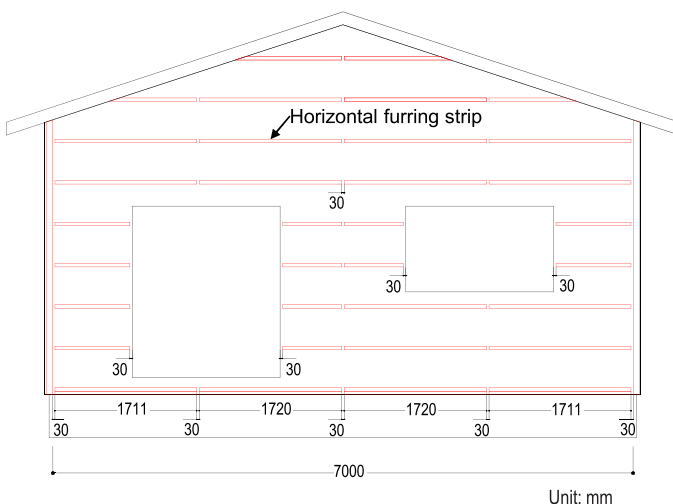

- Air flow

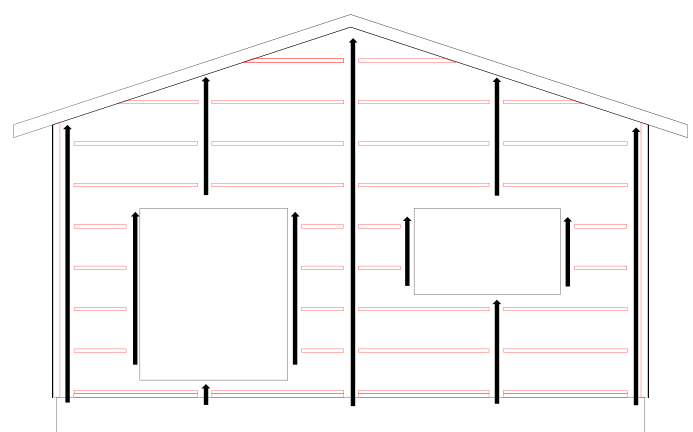

Vertical Application

3. Starter bar installation along sills

- Starter bars for vertical application on the sill serve as the base of the CERA FAÇADE panels and bear the entire weight of the panels.
- Mark a level line, 46mm from the sill flashing top as shown on the drawings below for the Starter bars to end up with approximately 10 mm ventilation gap between the bottom of the CERA FAÇADE panels and the sill flashing.
- The distance between screws to fasten the starter bars must not exceed 455 mm.
- Fasten the Starter bars securely along the mark with clip screws.

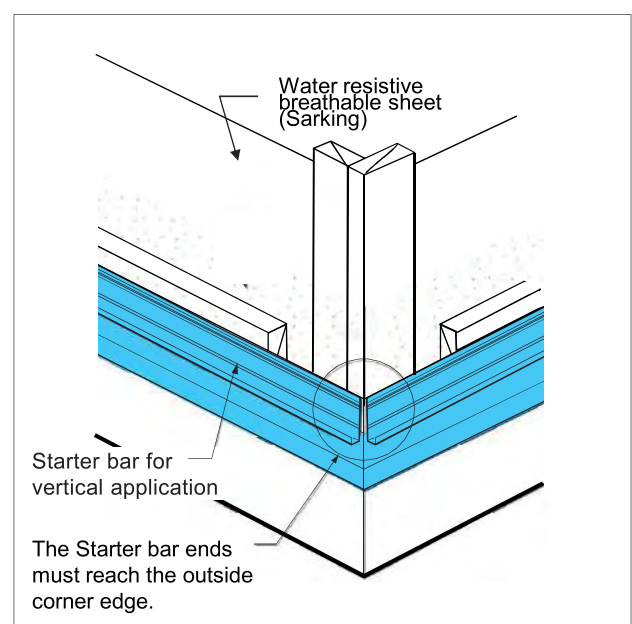
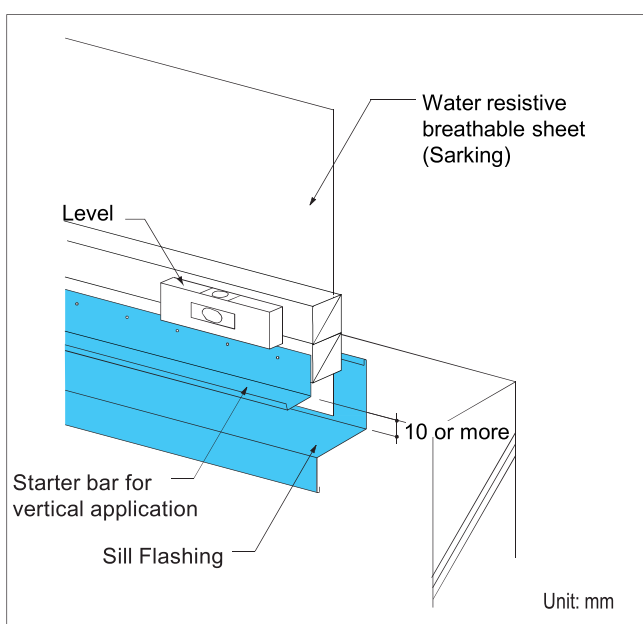
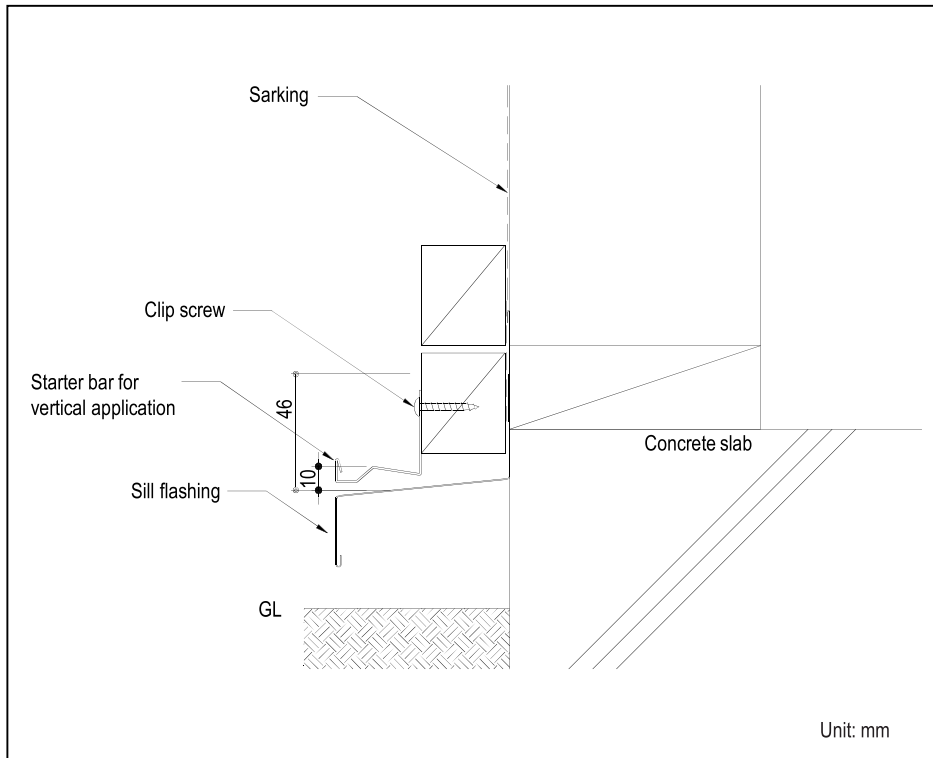

Vertical Application

4. First CERA FAÇADE panel installation

- Begin installing the first CERA FAÇADE panel by working from an outside or inside corner.
- Make sure that the panel is level and sits squarely on the starter bar for vertical application as shown.
- The first CERA FAÇADE panel is fastened to the furring strips with nails one side (next to an outside or inside corner) and panel clips the other side.
- The panel clip is the same clip for Horizontal application.
- Fasten the first clip right above the starter bar as shown on the diagram below.

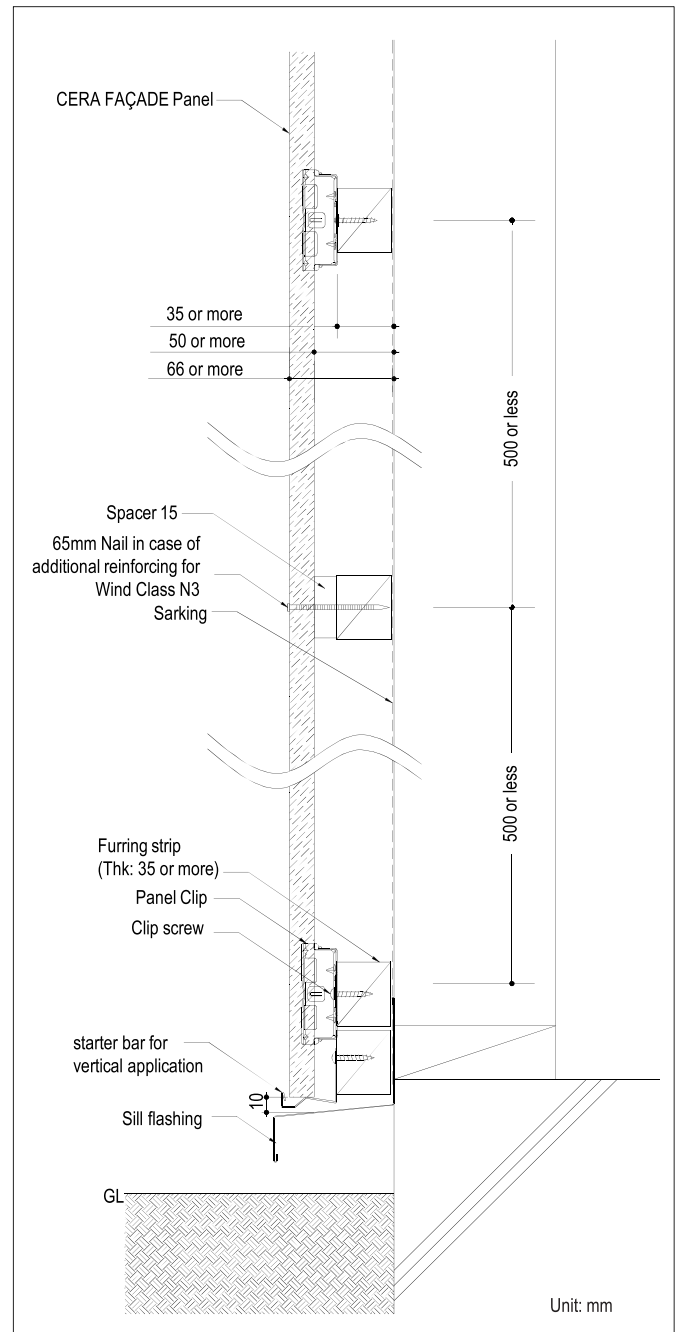
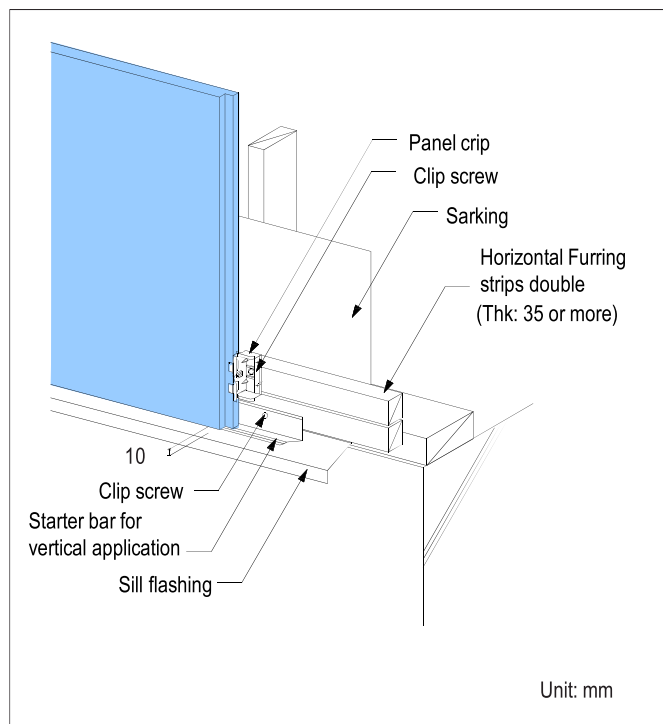

Vertical Application

5. Clip installation

- Fasten the panel clips securely on each horizontal furring strip with one screw per clip.
- Maximum distance between clips must not exceed 500mm, so that one CERA FAÇADE panel, in case of full length of 3,030 mm, requires seven clips.
- At outside and inside corners, and openings where the shiplaps are removed, clips cannot be used. So use nails instead in those areas.

(1) Sealant finish

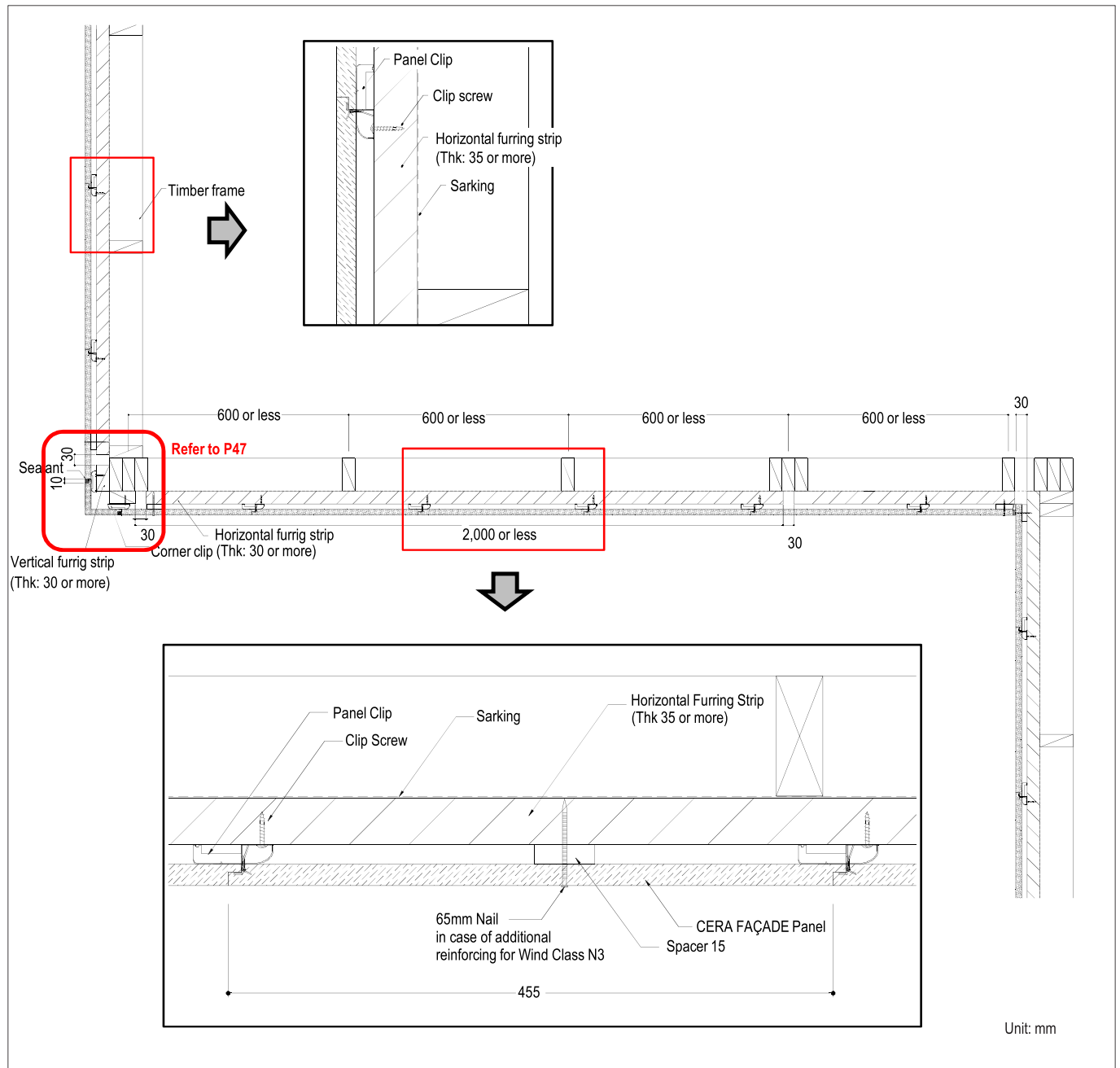

Vertical Application

6. Through Wall Flashing

- Apply sealant on the top of the panel and install through wall flashings on it.
- Apply sealant (local purchase) after applying a primer specified by the local manufacturer on the surfaces where the sealant is applied.
- Install starter bars for vertical application with clip screws.
- The distance between screws to fasten the starter bars must not exceed 455mm.
- Fasten a clip right above the starter bar as shown on the diagram below.

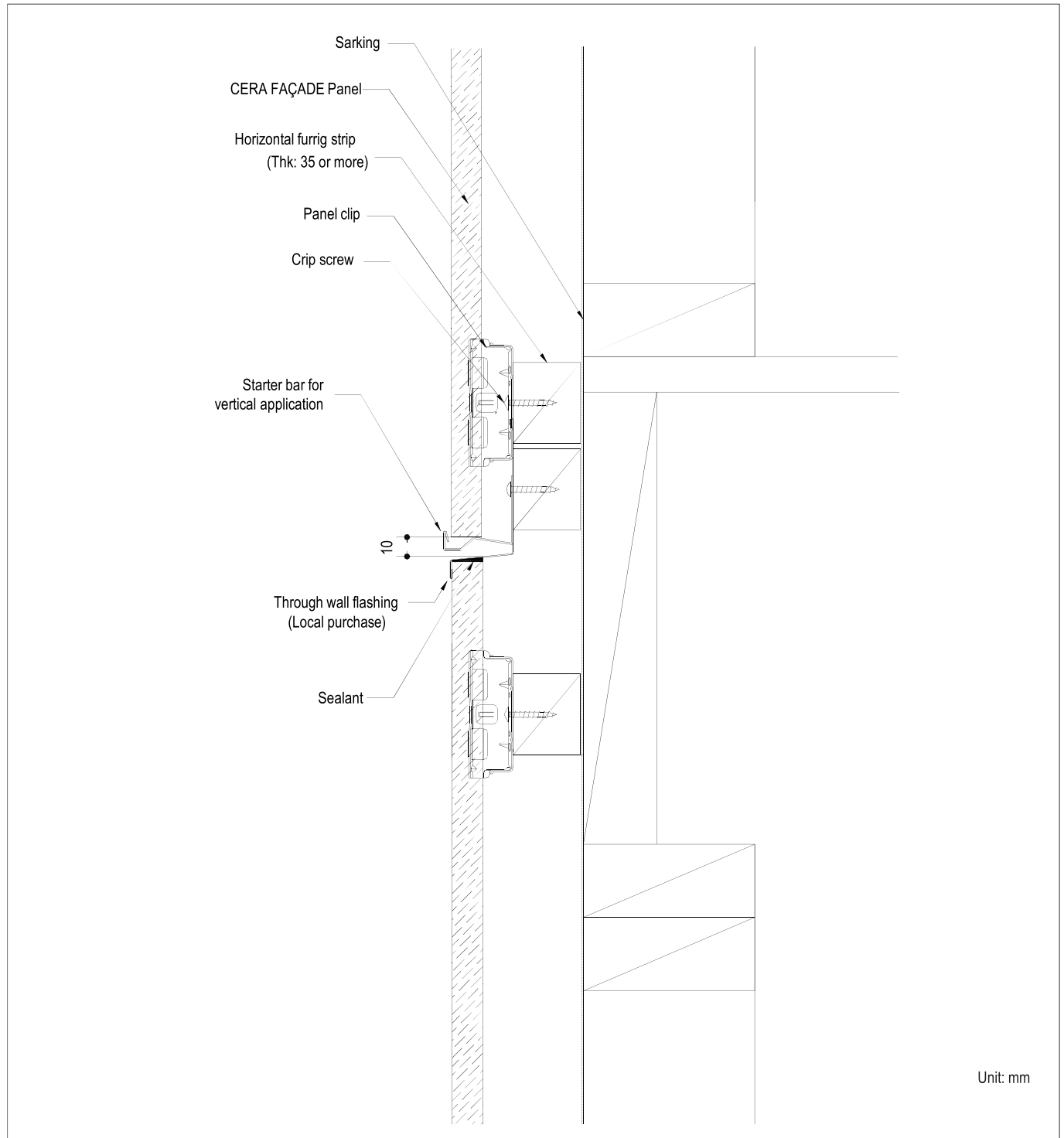

Vertical Application

7. Outside corner finishing

(1) Metal outside trims

- Metal outside trim to be made from material complying with AS/NZS 2728.
- Attach Spacer 15s to the vertical furring strips at the corner with interval of 500mm or less.
- Fasten metal corner trim onto the spacer 15s with nails.
- Insert CERA FAÇADE panels into the metal corner trim, predrill pilot holes and fasten them to the furring strips with 65mm nails.

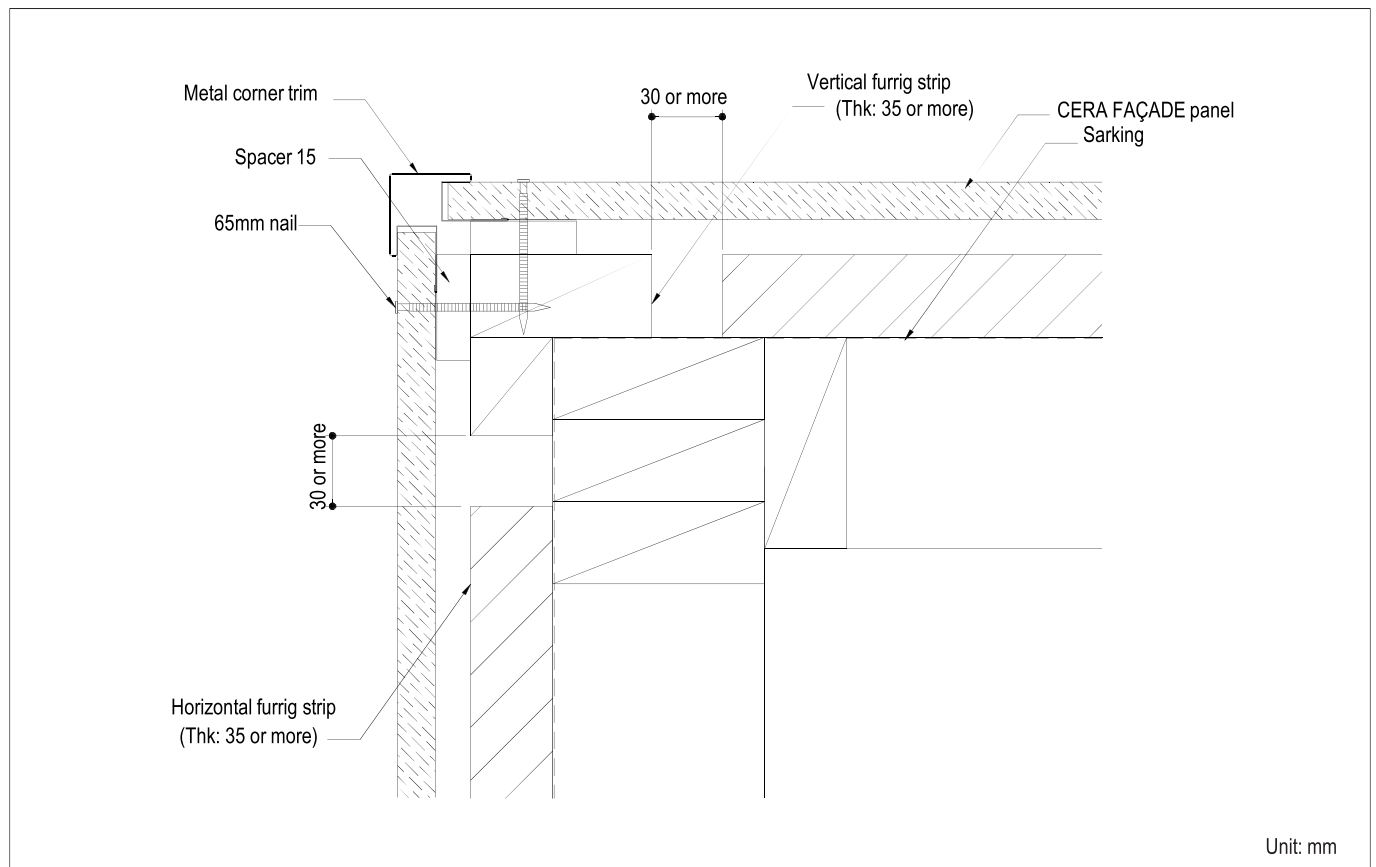
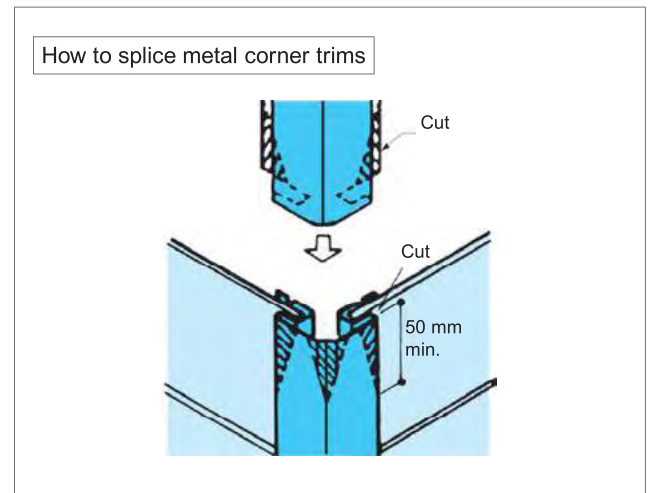

Vertical Application

(2) Timber corner caps

- Attach Spacer15s to the corner over the vertical furring strips as shown on the diagram below.
- Incorporate one-side hat-shaped joiners as shown on the diagram below.
- Install the CERA FAÇADE panels so that they butt-up to the one-side hat-shaped joiners at the corner. Apply sealant in the joint.
- Apply sealant (local purchase) after applying a primer specified by the local manufacturer on the surfaces where the sealant is applied.
- Drill pilot holes (approx. 2mm diameter) in the timber corner caps and CERA FAÇADE panels with 500 mm or less pitch, and then nail on the corner caps.
- Corner caps should be securely fastened on the stud, not on CERA FAÇADE panels.

Very Important!

Caution

Without drill pilot holes in CERA FAÇADE panels, CERA FAÇADE panels will be broken.

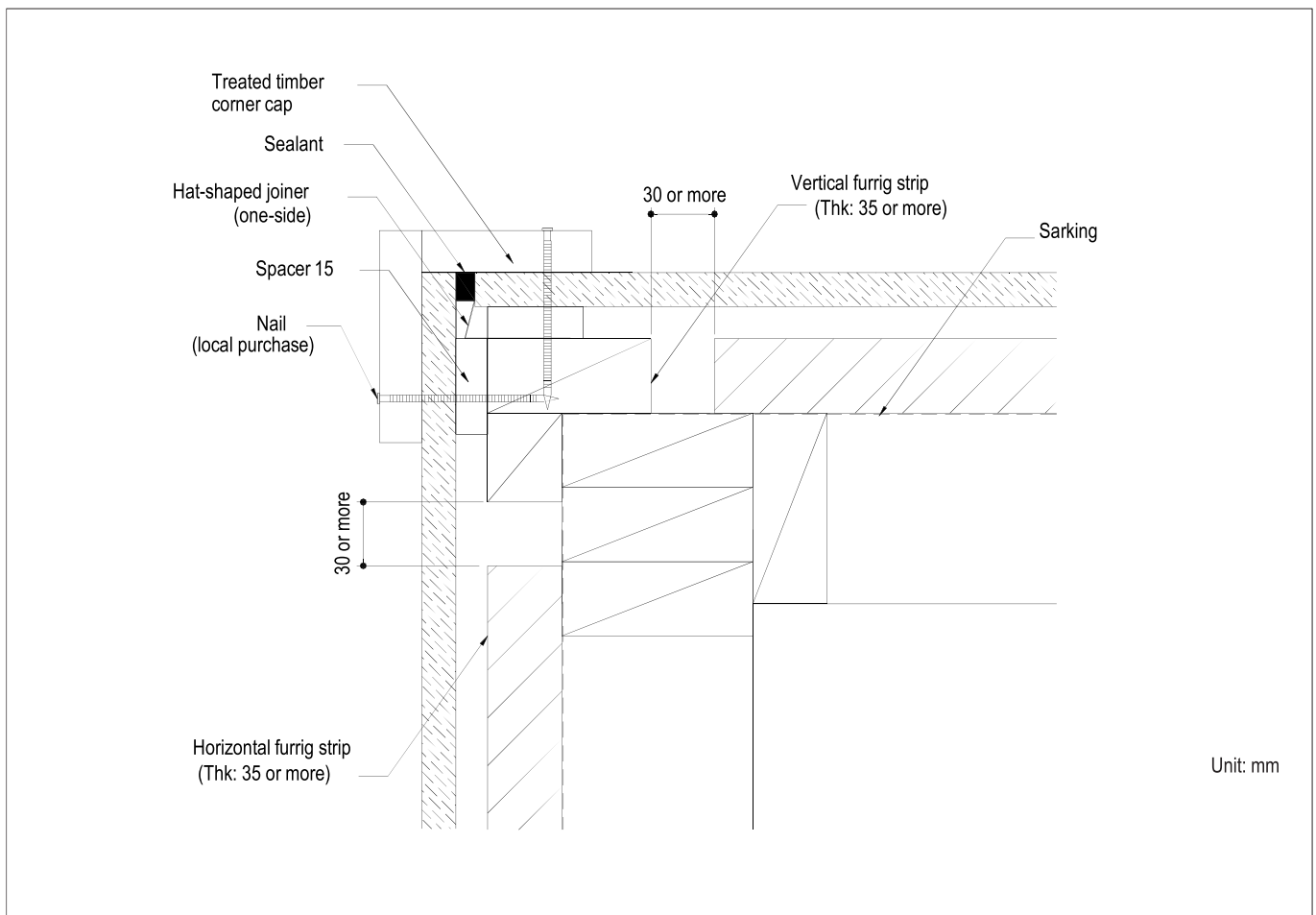

Vertical Application

(3) Corner cladding (made of matching materials)

- Ensure that the corner claddings are level.
- Install the corner claddings with corner clips for vertical application. For the Modinex trims, cut off the both shiplaps of a corner cladding and install the Modinex trim (bottom) as shown.
- Install CERA FAÇADE panels to butt up to the corner cladding.
- Make sure that the ship laps of the panels which are to butt up to the corner cladding or the Modinex trim are removed.
- Insert spacer 15s, predrill pilot holes and fasten the panels with 65mm nails to the vertical furring strips.
- Apply sealant in the joints or install the Modinex trim (top) as shown.
- Apply sealant (local purchase) after applying a primer specified by the local manufacturer on the surfaces where the sealant is applied.

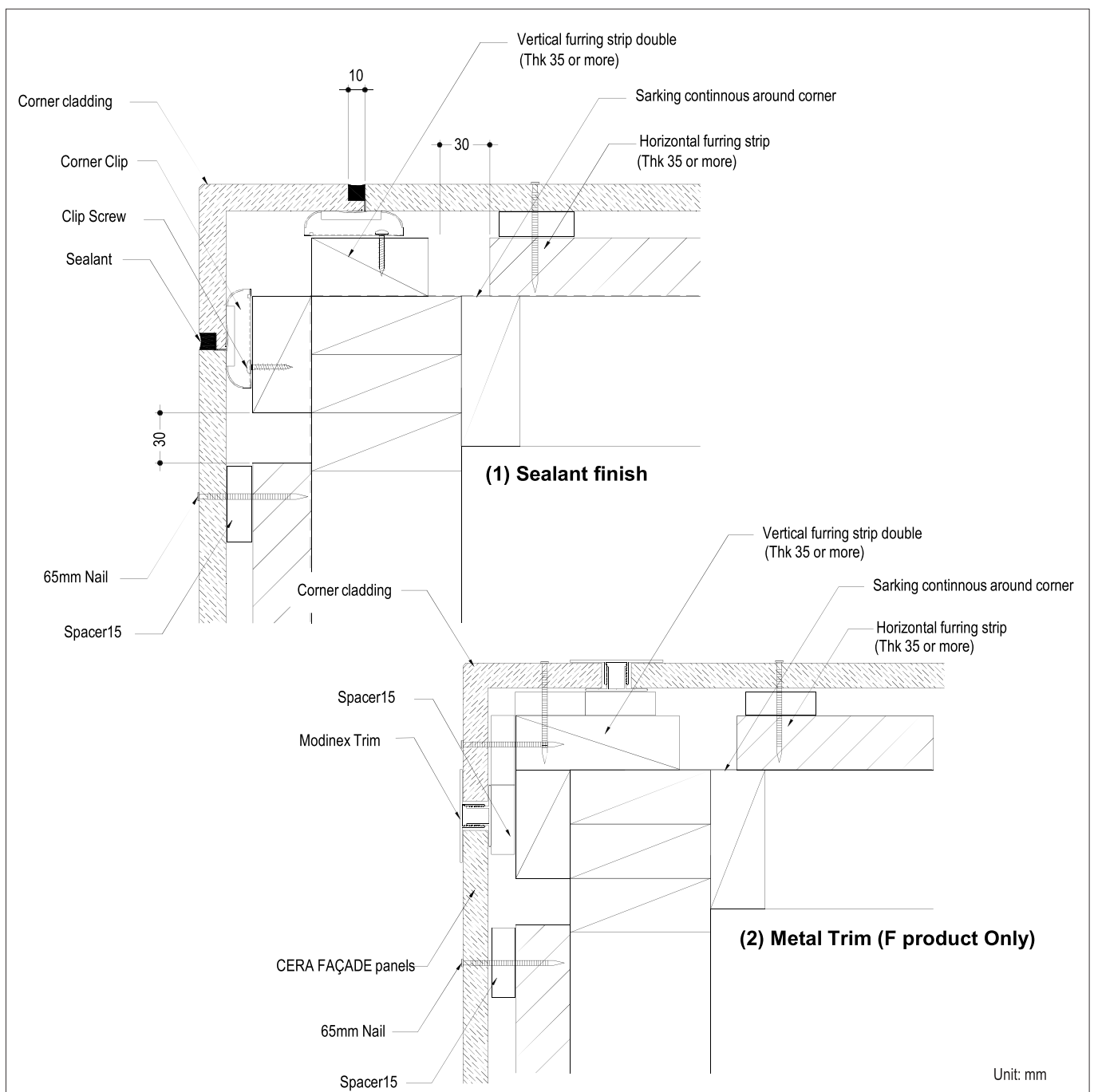

Vertical Application

8. Inside corner finishing

(1) Sealant finish

- Attach Inside corner flashings to inside corners.
- After completion of panel installation on a wall, fasten hat-shaped joiners (one-side) at the corner.
- Install the CERA FAÇADE panels on the other wall so that they butt-up to the hat-shaped joiners (one-side).
- Apply sealant in the joints. Apply sealant (local purchase) after applying a primer specified by the local manufacturer on the surfaces where the sealant is applied.

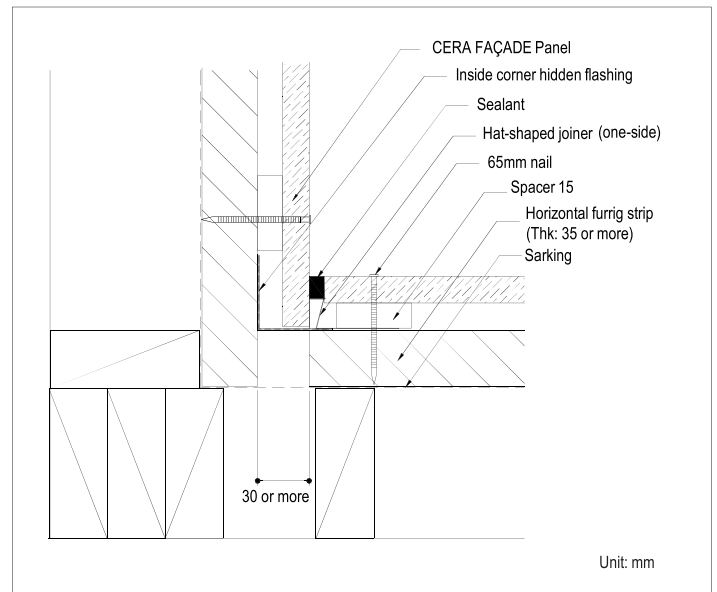

(2) Metal inside trim (F product only)

- Spacer thickness should be adjusted for the metal inside trim (locally produced) so that unevenness is within the 2mm requirement.
- The metal trims should meet local requirements such as Corrosivity Zone (AS4312). Refer to page 13.

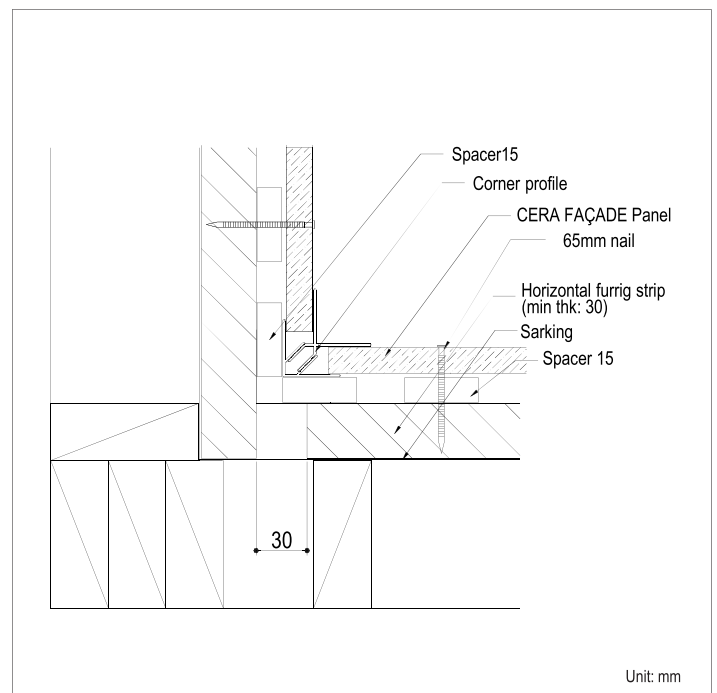

Vertical Application

9. Under eaves

(1) Eave liner

- Install the CERA FAÇADE panels with panel clips as shown on the diagram.
- Make sure that air from cavity is ventilated out through the eave or attic/roof ventilation system.
- Provide sufficient protection on the CERA FAÇADE panels before application of paint on the eave liner and eave sheet.

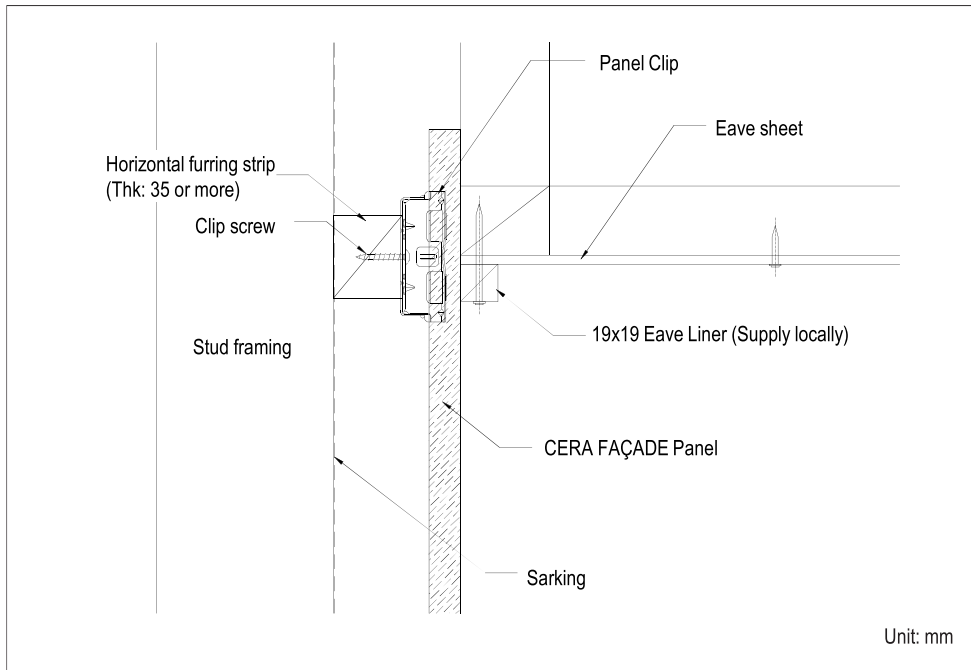

(2) Ventilating Soffit Flashing

- Install ventilating soffit flashing under the soffit.
- Fasten soffit flashing with spacer15 and screws onto the horizontal furring strips.
- Insert CERA FAÇADE panel into the ventilating soffit flashing so to have cut edges of the panels are covered.

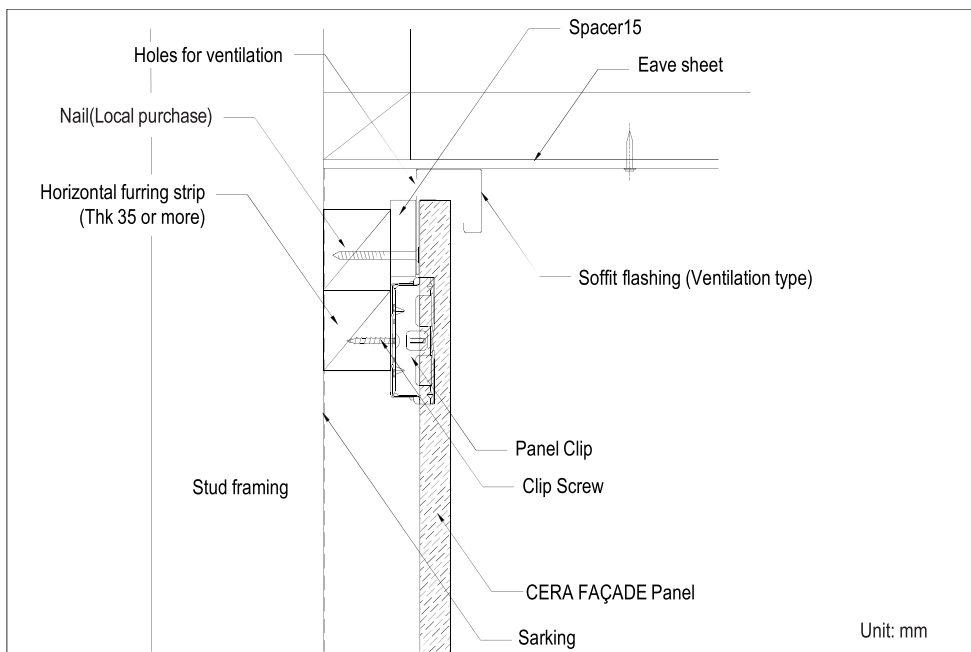

Vertical Application

10-1. Opening (Permanently-set window)

<Above opening>

- Install a metal flashing above the window, and then cover the metal flashing with water resistive building sheet (Sarking).
- Metal flashing should have 15 degree slope and a 60 mm upstand as shown on the diagram right.
- Install starter bars for vertical application so as to maintain approximately 10 mm of space between the metal flashing and the CERA FAÇADE panel.
- To fix the CERA FAÇADE panel above the opening, use the panel clips as shown on the diagram right.

<Under opening>

- Use locally supplied metal flashing for under opening.
- Sarking must be firmly fixed around the window with double-sided waterproof tape.
- To fix the CERA FAÇADE panel under the opening, use panel clips.
- Apply sealant (local purchase) after applying a primer specified by the local manufacturer on the surfaces where the sealant is applied.

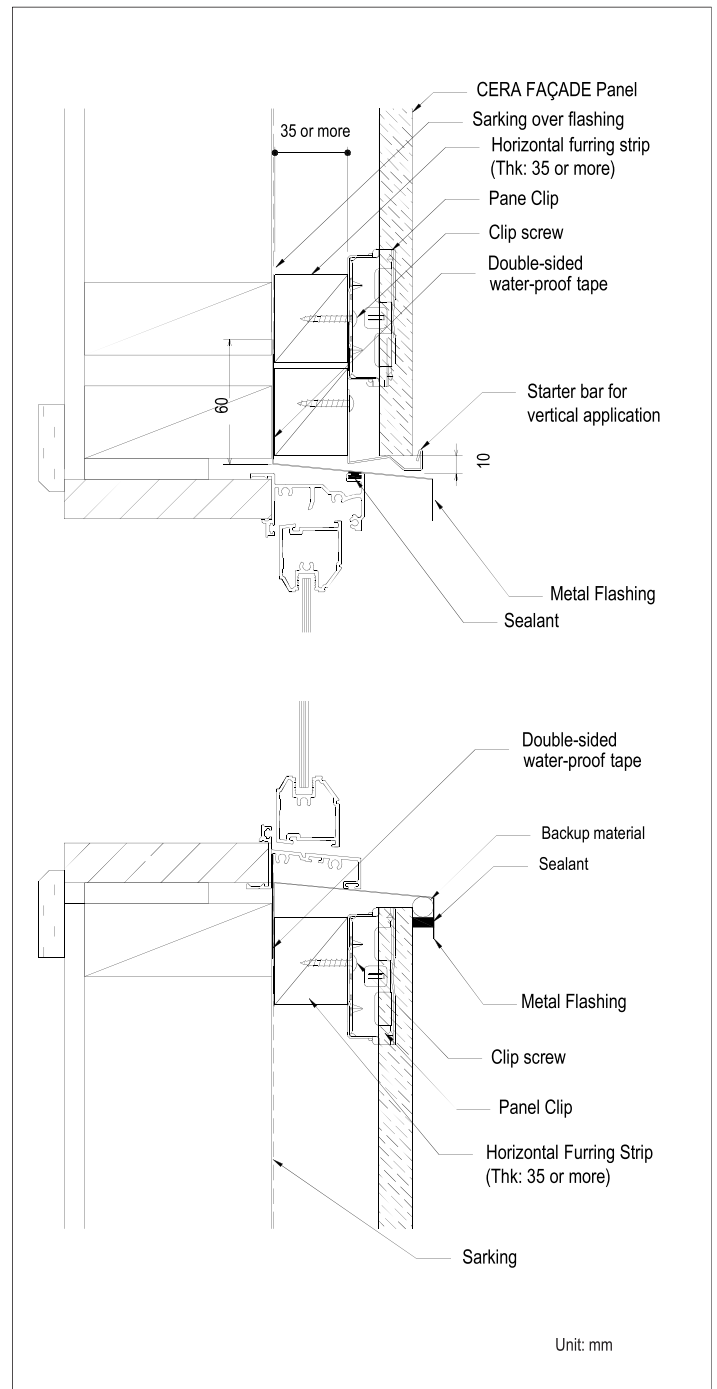

Vertical Application

10-1. Opening (Permanently-set window)

<Side opening>

- Sarking must be firmly fixed around the opening with double-sided waterproof tape.
- Install locally supplied metal flashing to the side of opening.
- Insert spacer15s, predrill pilot holes (approx. 2mm) and fasten the CERA FAÇADE panel with 65mm nails.
- Use sealant as necessary to improve weather tightness. Apply sealant (local purchase) after applying a primer specified by the local manufacturer on the surfaces where the sealant is applied.

For the solid core product (16mm, CERA FAÇADE F), Water-Sealing Materials (WSM) is not required to the metal flashing. However, appropriate waterproofing methods should be applied to joints at window/door frames to minimize water in to the cavity as a local common practice as necessary, for which KMEW is not responsible.

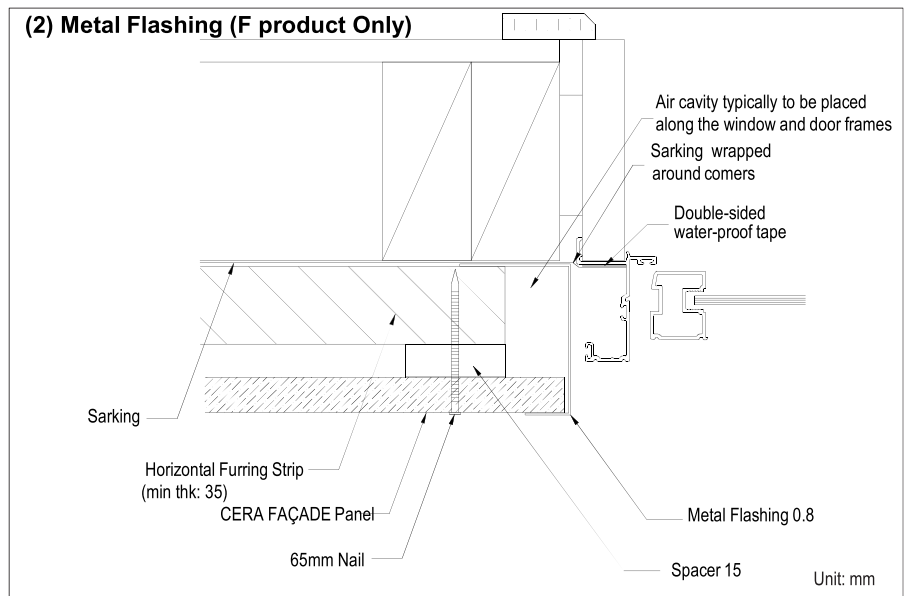
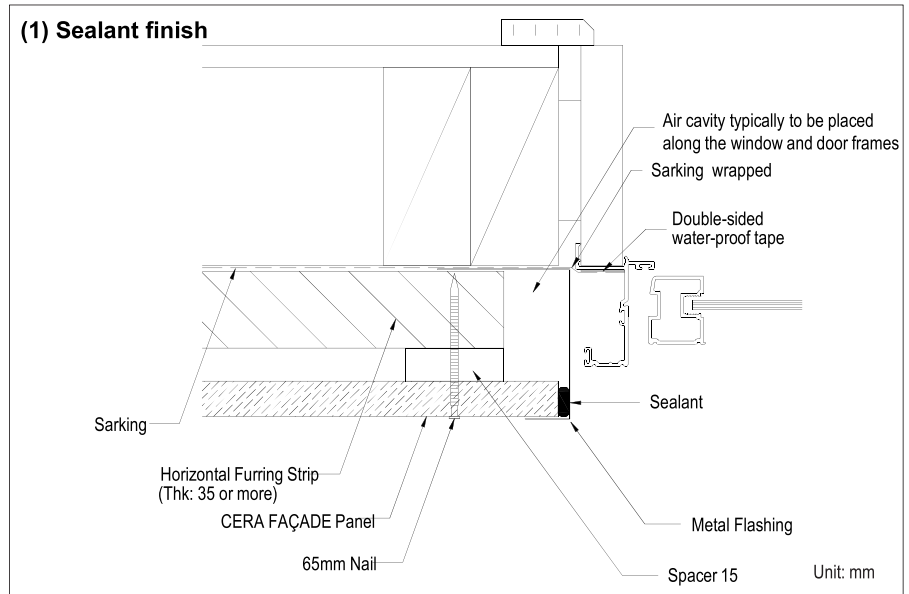

Vertical Application

10-2. Opening (Sliding window)

<Above opening>

- Install a metal flashing above the window, and then cover the metal flashing with water resistive building sheet (Sarking).
- Metal flashing should have 15 degree slope and a 60 mm upstand as shown on the diagram right.
- Install starter bars for vertical application so as to maintain approximately 10 mm of space between the metal flashing and the CERA FAÇADE panel.
- To fix the CERA FAÇADE panel above the opening, use the panel clips as shown on the diagram right.

<Under opening>

- Use locally supplied metal flashing for under opening.
- Sarking must be firmly fixed around the window with double-sided waterproof tape.
- To fix the CERA FAÇADE panel under the opening, use panel clips.
- Apply sealant (local purchase) after applying a primer specified by the local manufacturer on the surfaces where the sealant is applied.

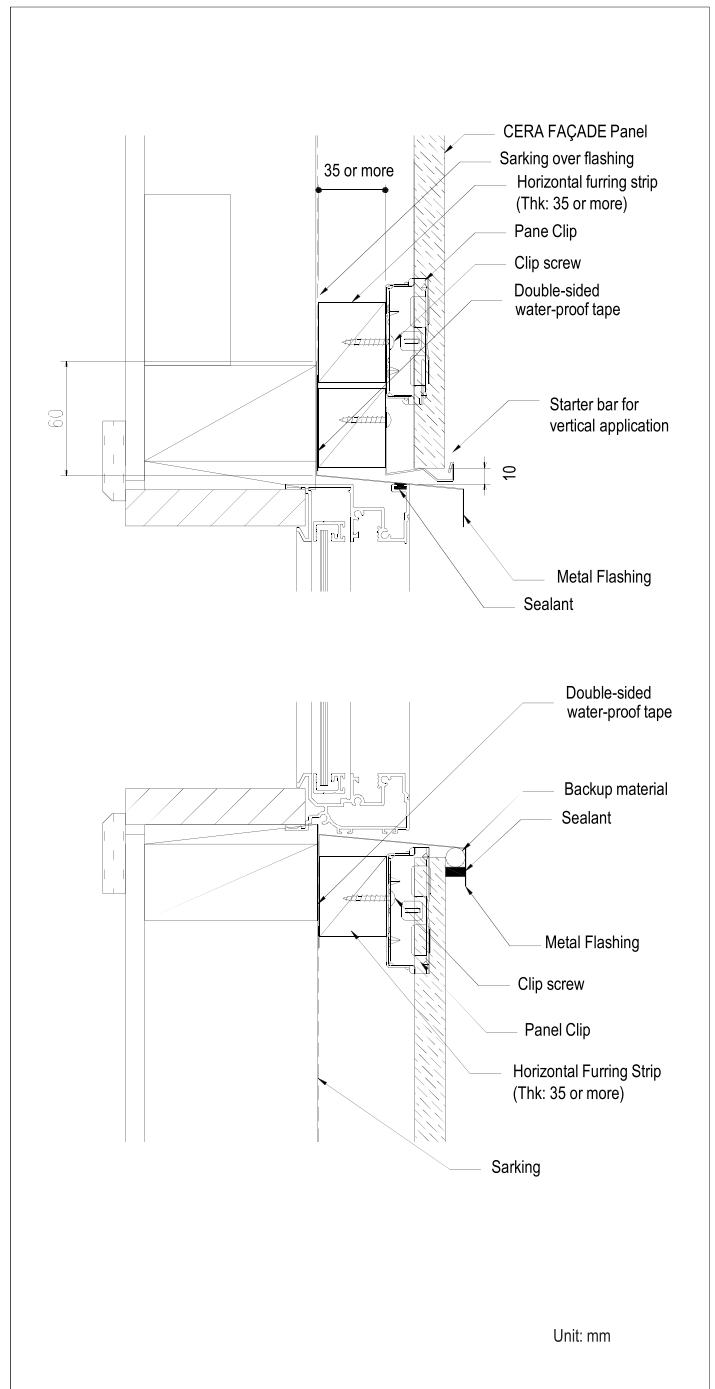

Vertical Application

10-2. Opening (Sliding window)

<Side opening>

- Sarking must be firmly fixed around the opening with double-sided waterproof tape.
- Install locally supplied metal flashing to the side of opening.
- Insert spacer15s, predrill pilot holes (approx. 2mm) and fasten the CERA FAÇADE panel with 65mm nails.
- Use sealant as necessary to improve weather tightness. Apply sealant (local purchase) after applying a primer specified by the local manufacturer on the surfaces where the sealant is applied.

For the solid core product (16mm, CERA FAÇADE F), Water-Sealing Materials (WSM) is not required to the metal flashing. However, appropriate waterproofing methods should be applied to joints at window/door frames to minimize water in to the cavity as a local common practice as necessary, for which KMEW is not responsible.

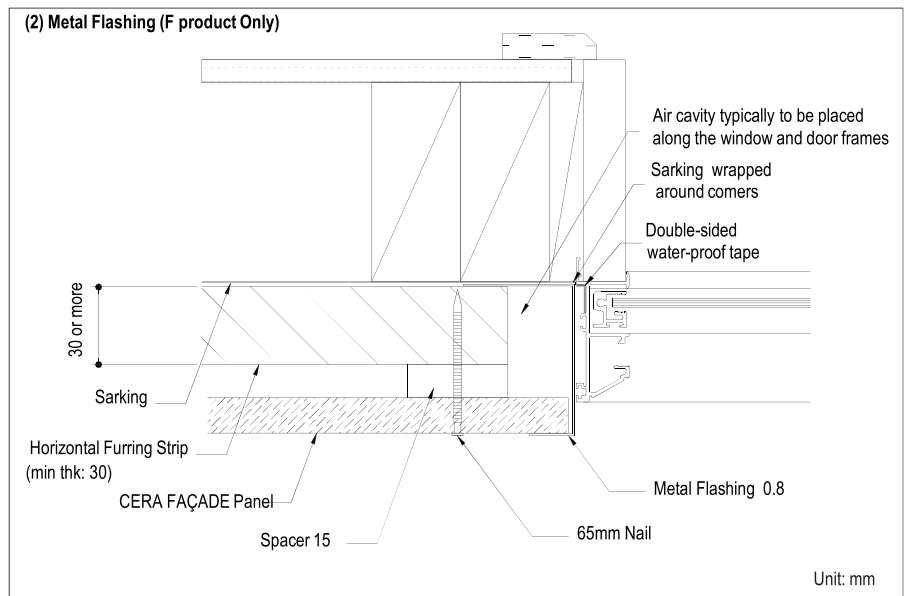
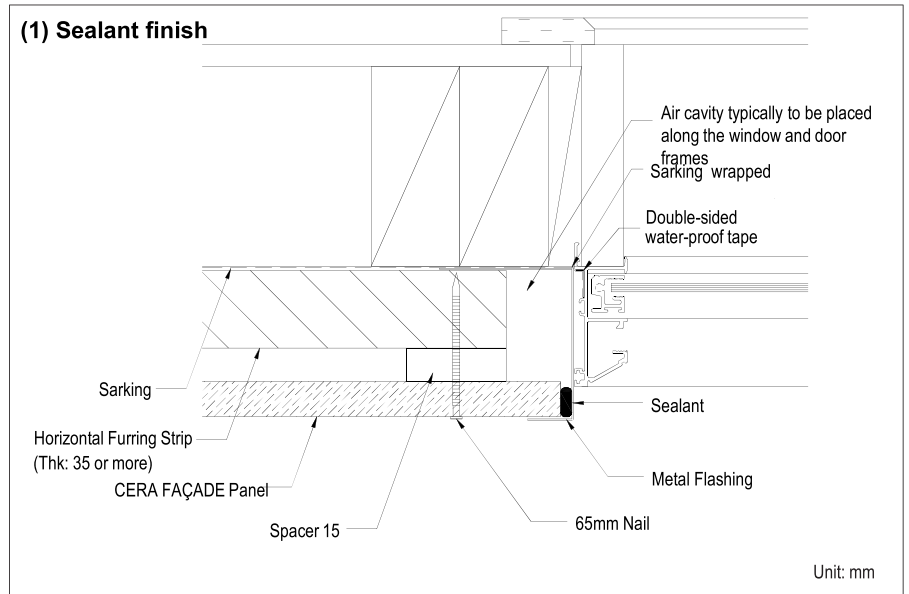

Vertical Application

11. Intersection with roof

- CERA FAÇADE Panel and roof flashing should be installed with a gap of about 10 to 15 mm. (To prevent capillary phenomenon, maintain air intake, drain condensation)
- Waterproof breathable building paper (Sarking) should be overlapped on the roof flashing as shown below.
- Attach the sarking to the roof flashing with a double-sided water-proof tape to prevent the paper from rattling by wind and from leaping up in the air cavity. However, the double-sided water proof tape is not required in case that the sarking is stuck with horizontal furring strips, or starter bars.
- Place a 30mm or more gap every 2000mm or less of horizontal furring strips for air circulation. Refer to page 40.
- For Vertical application, starter bars for vertical application must be used for both ridge and slope sides as shown on below.

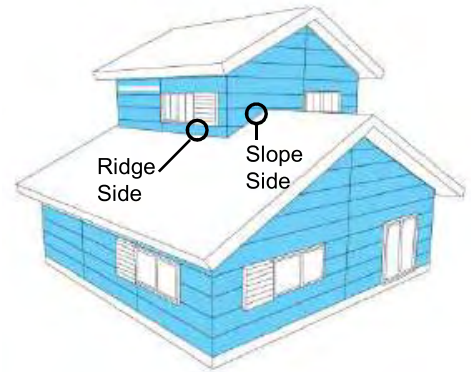

(1) Ridge Side

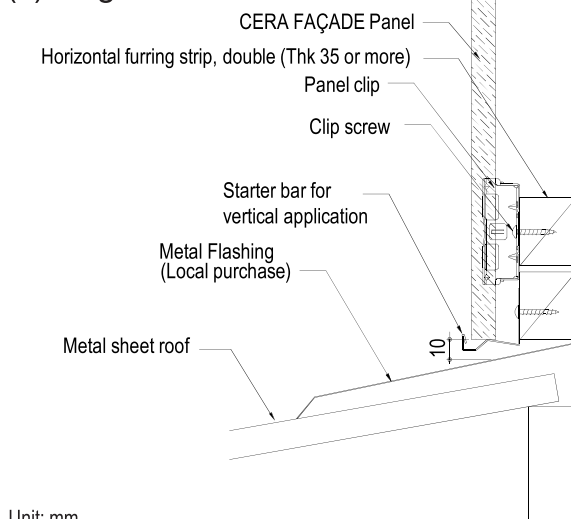

Unit: mm

Stud

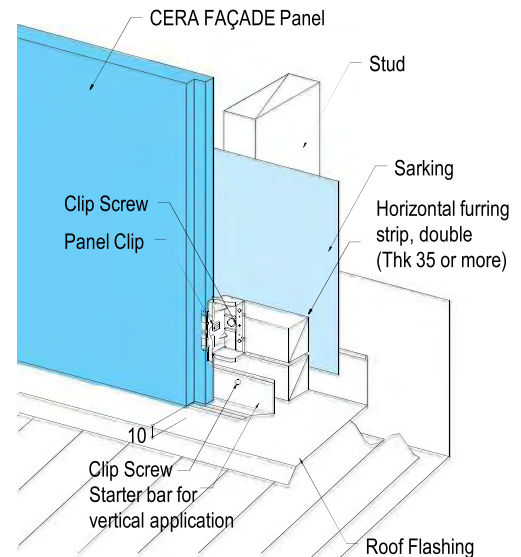

(2) Slope Side

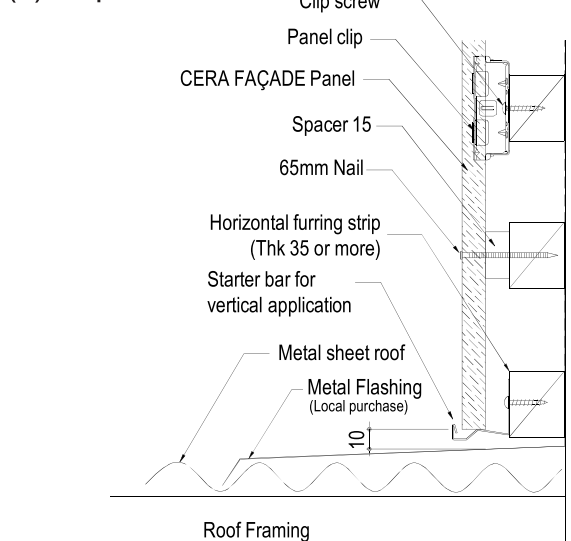

Unit: mm

Stud

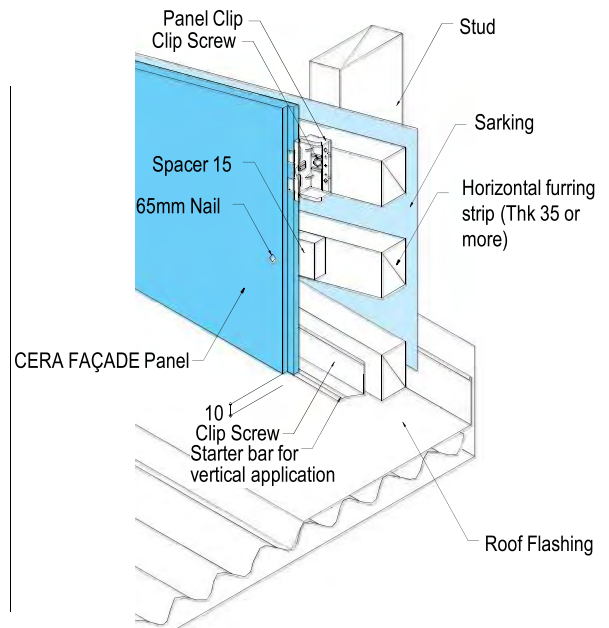

Other details

1. Overhang

(1) Horizontal application

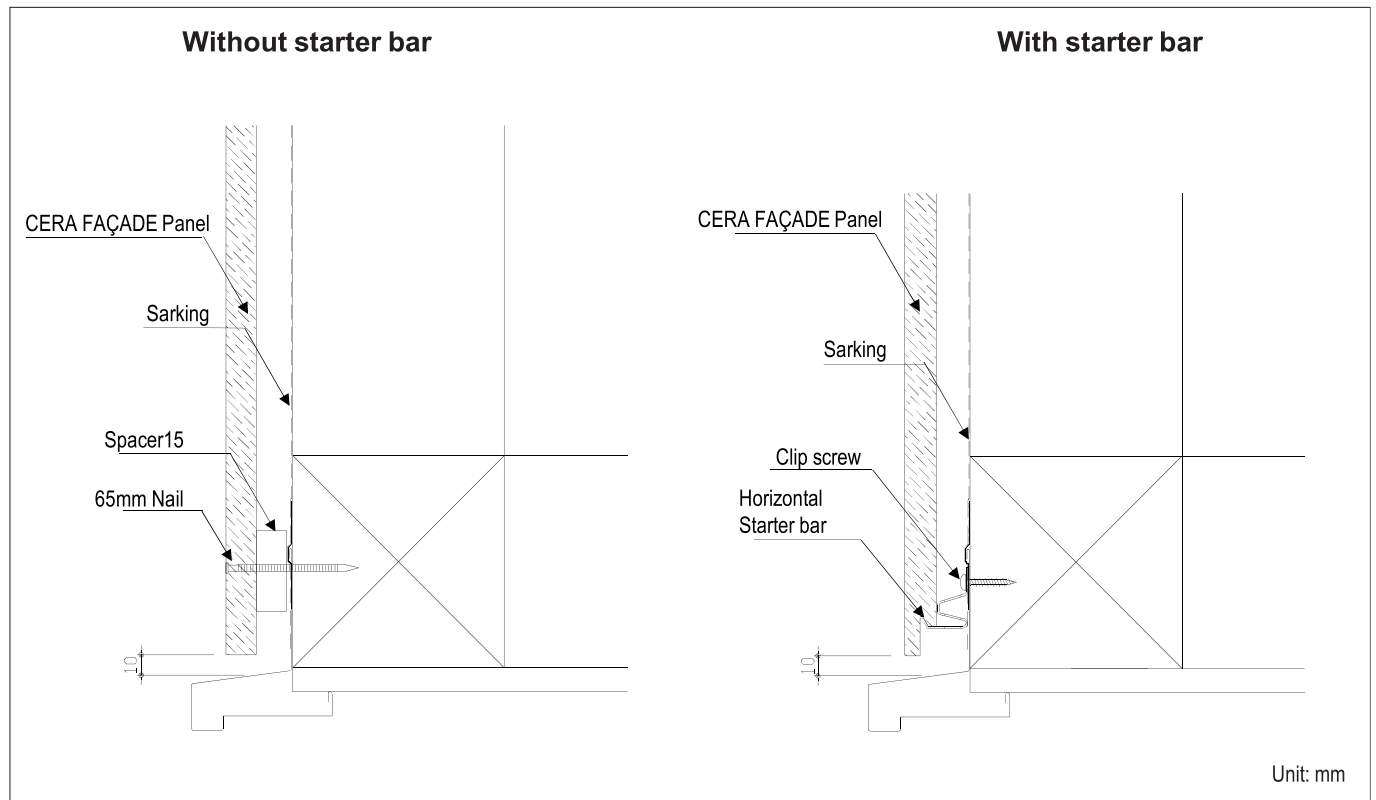

(2) Vertical application (with starter bars)

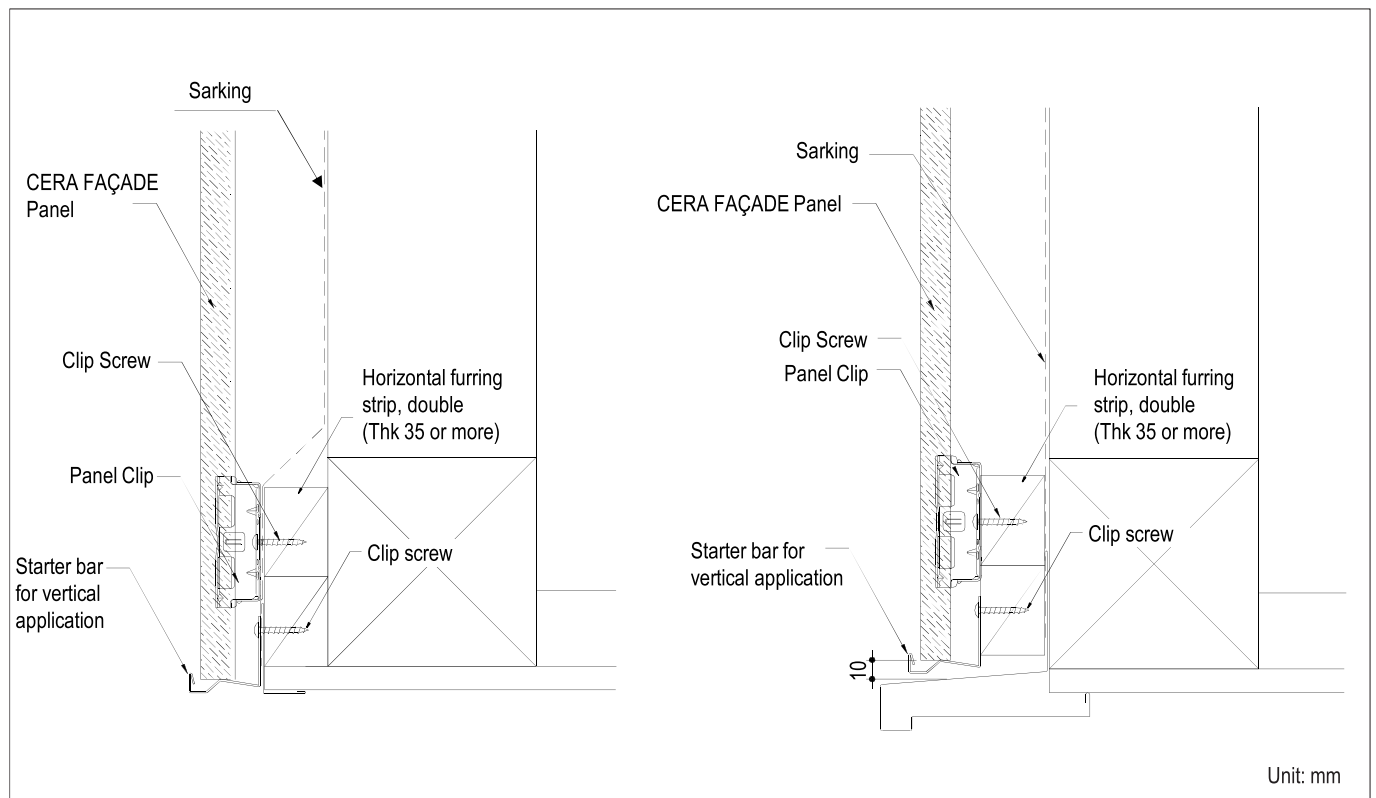

Other details

2. Coping

(1) Horizontal application

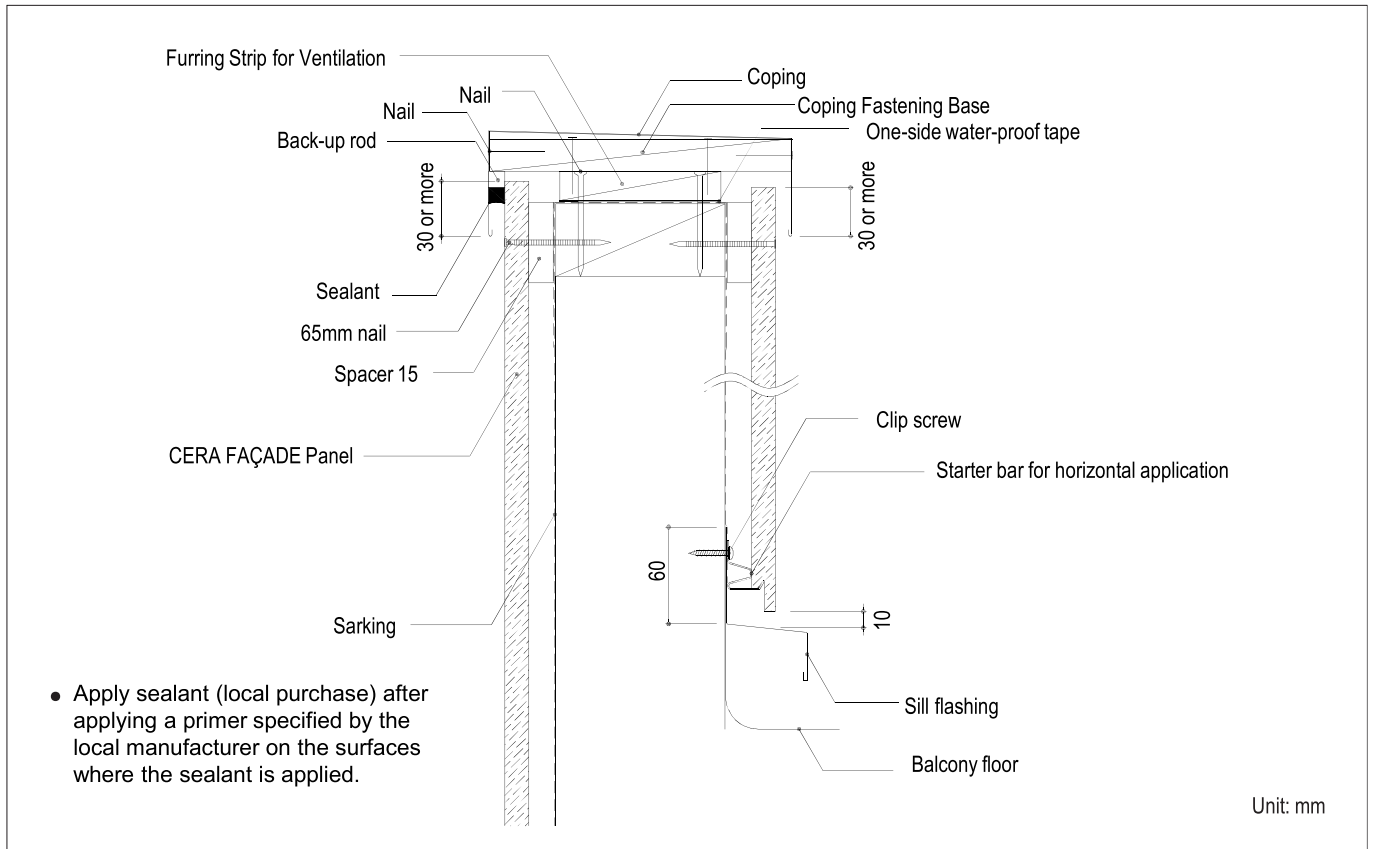

(2) Vertical application

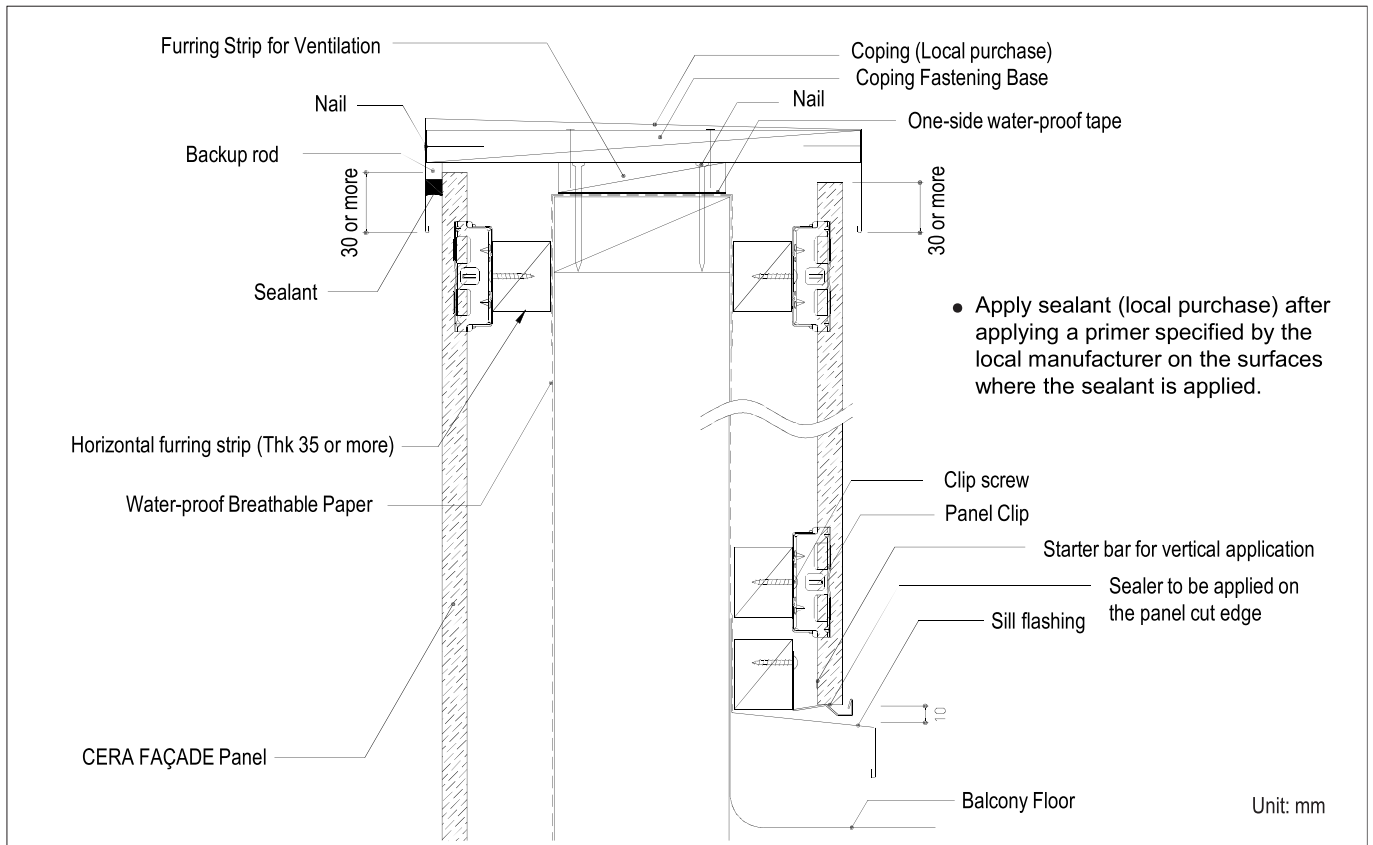

Other details

3a. Obtuse angle

(1) Horizontal application

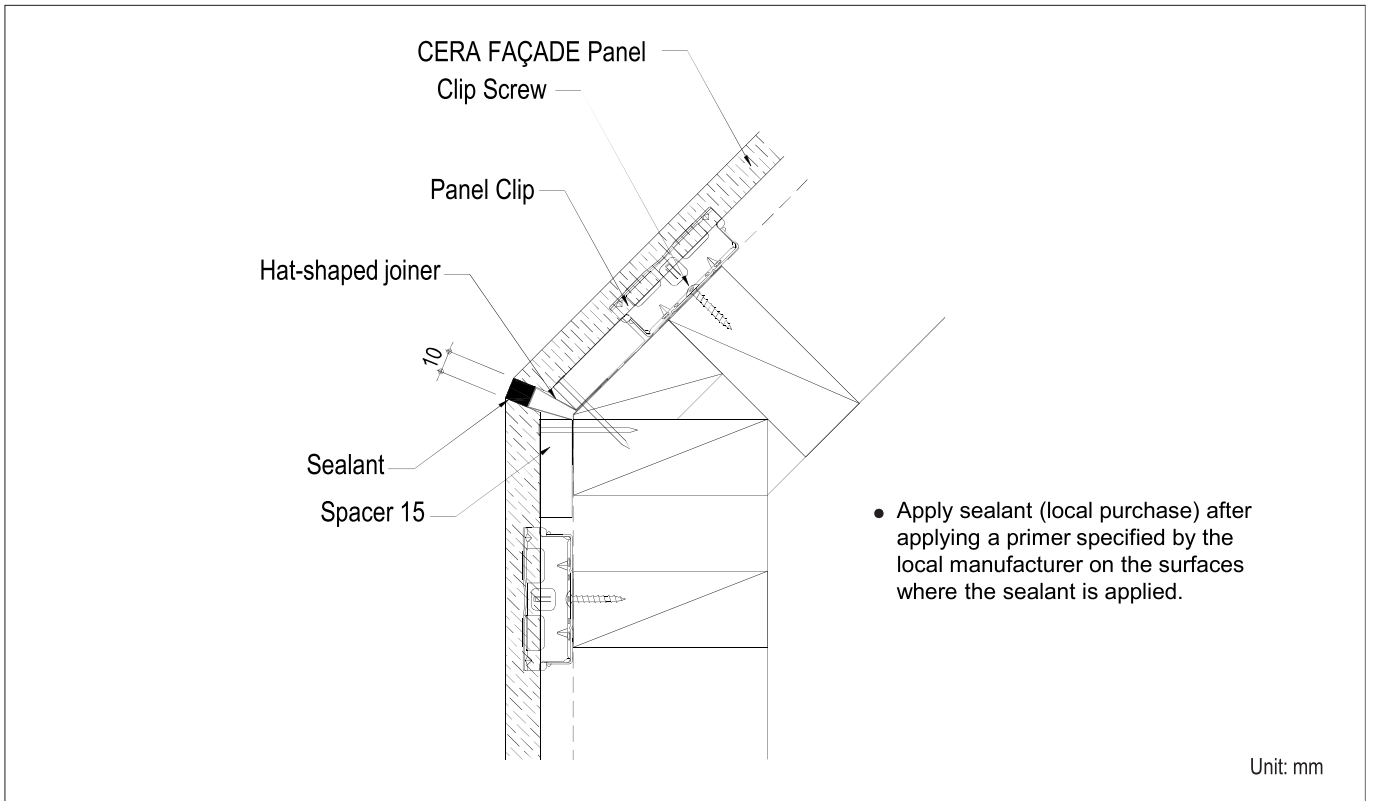

(2) Vertical application

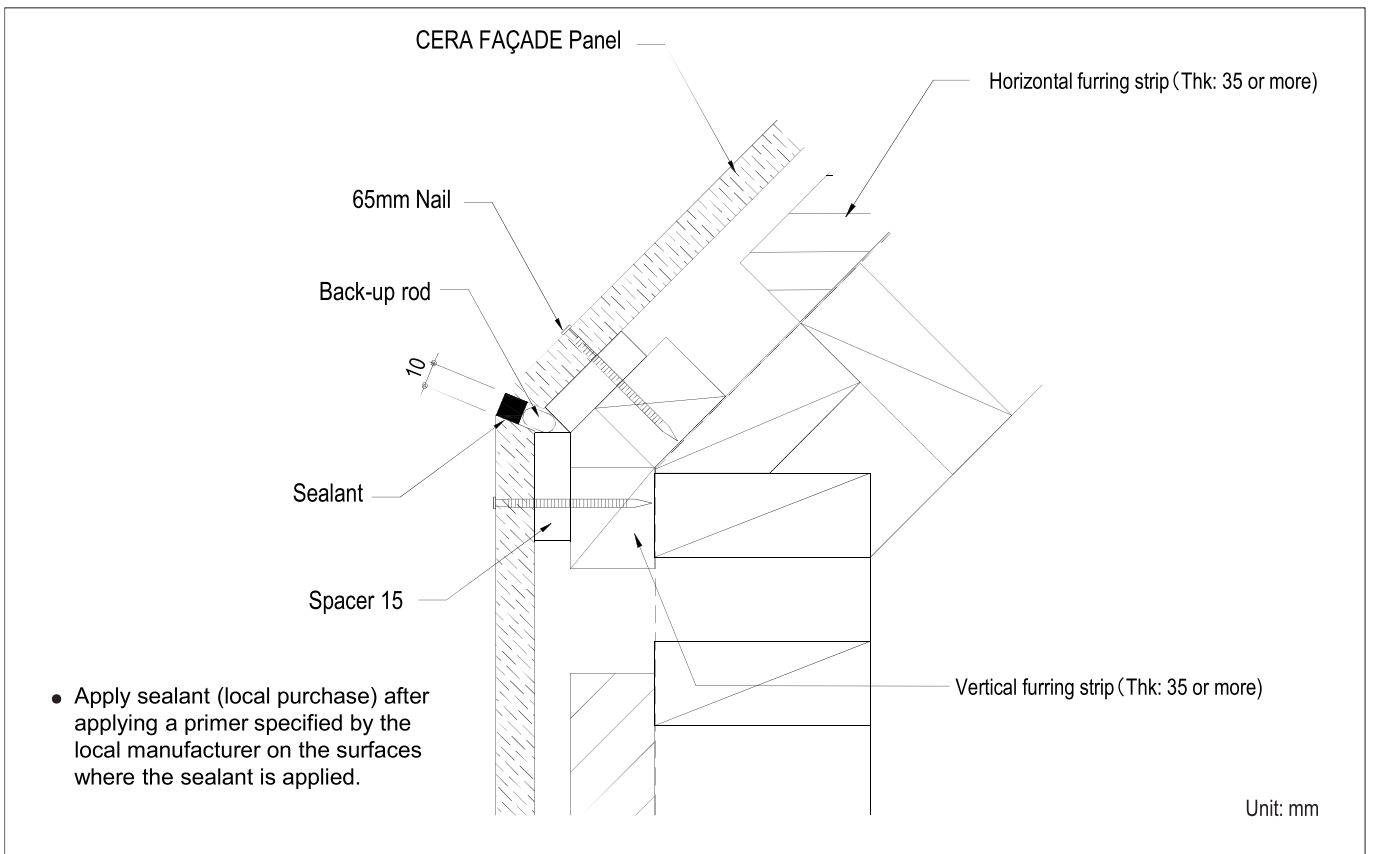

Other details

3b. Obtuse angle

(1) Horizontal application

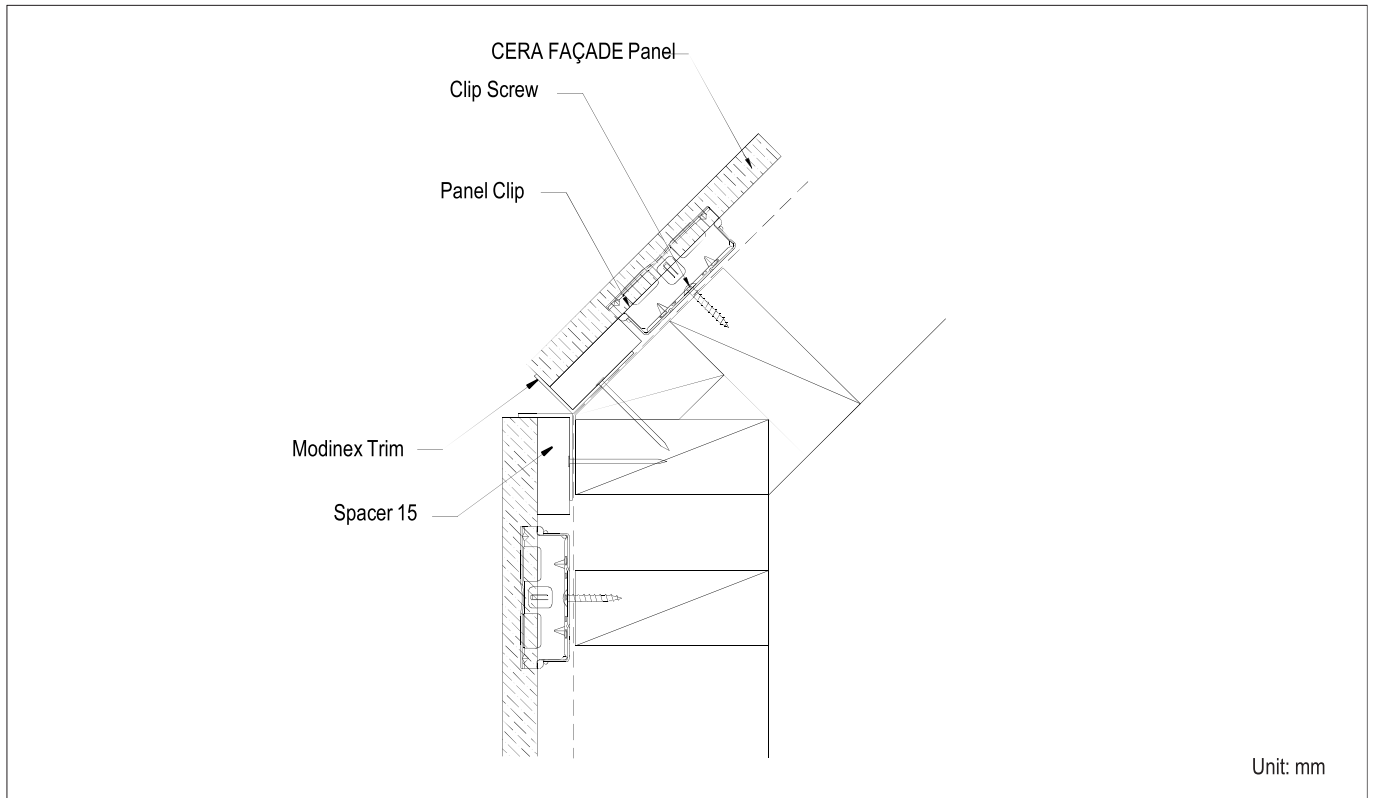

(2) Vertical application

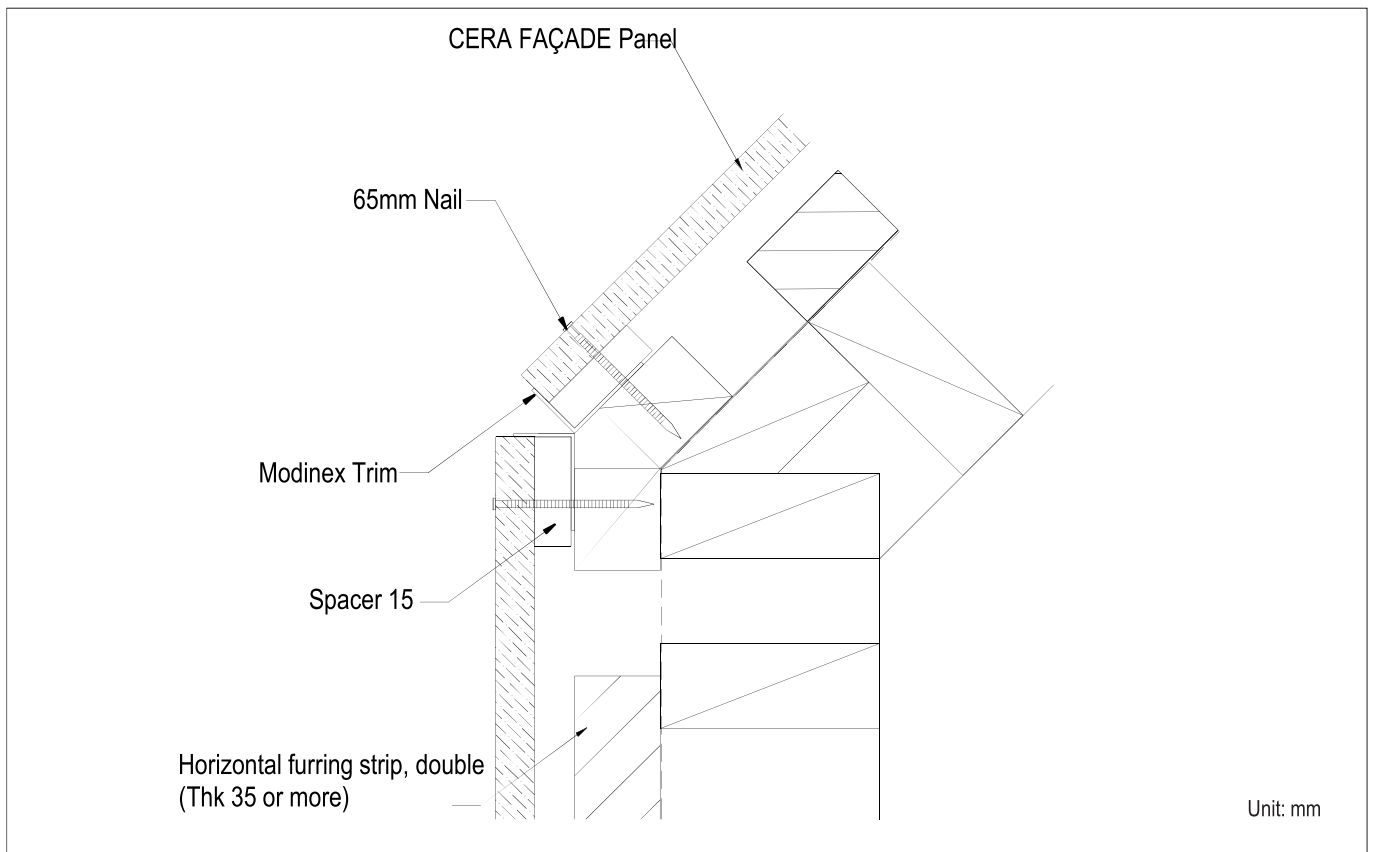

Other details

4. Installation Around Ventilation Ducts

- Keep 10mm of space between the hoods and the panels and apply Sealant.
- Separate the exhaust opening at least 30mm from the CERA FAÇADE Panel surface.



Securely apply Sealant on the connection of the pipe and hood to prevent humid air from entering the air cavity.

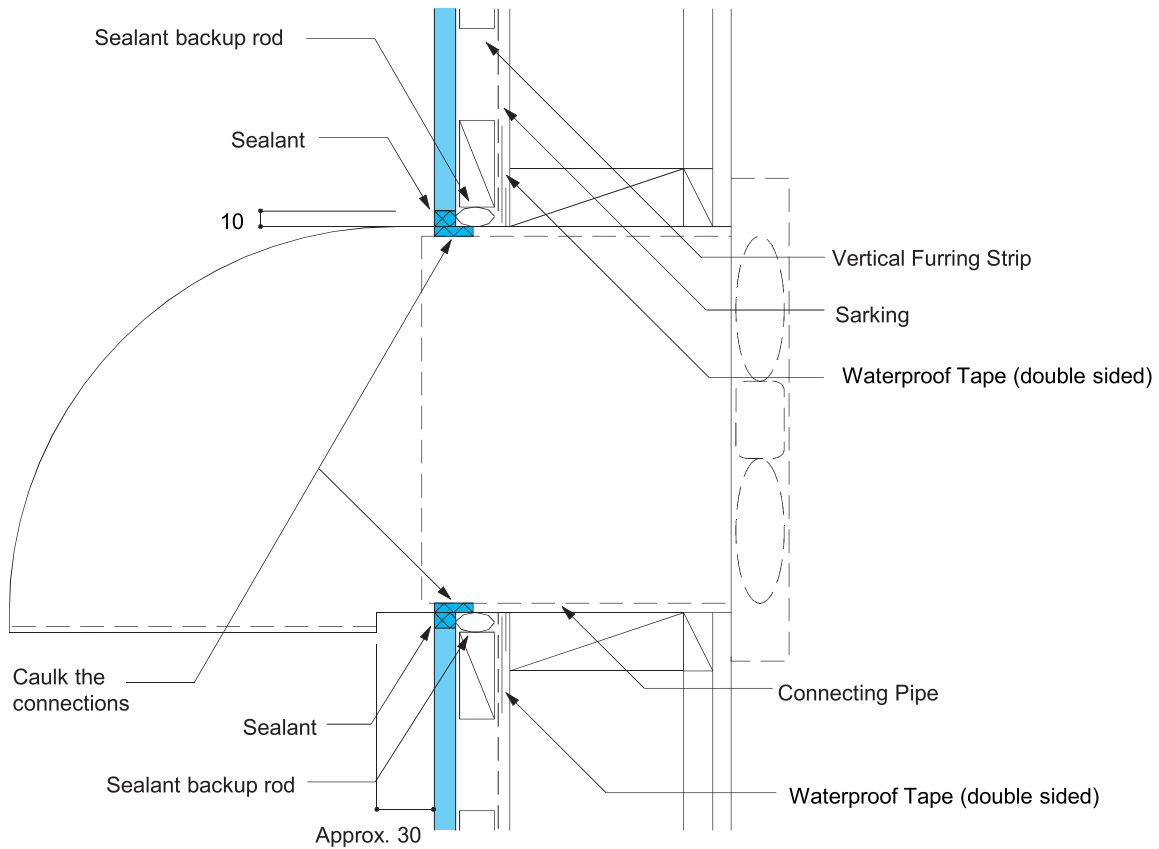

Unit: mm

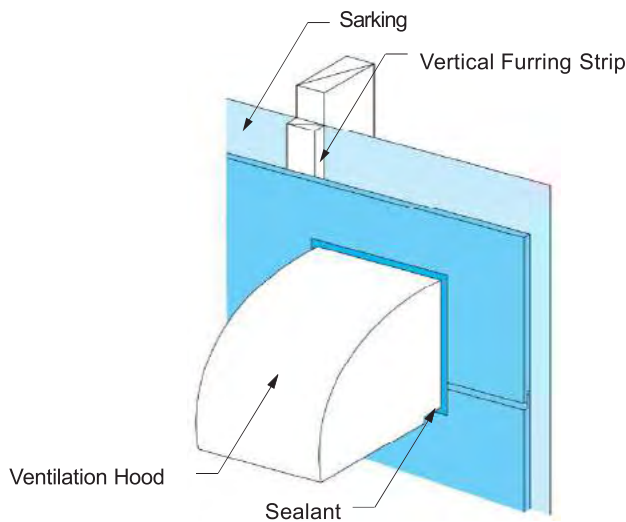

- Apply sealant (local purchase) after applying a primer specified by the local manufacturer on the surfaces where the sealant is applied.

Other details

5. Junctions with Other Materials

(1) Horizontal junction

Make sure to use flashing because the joints may fail if the CERA FAÇADE Panels are installed next to other materials without any separation.

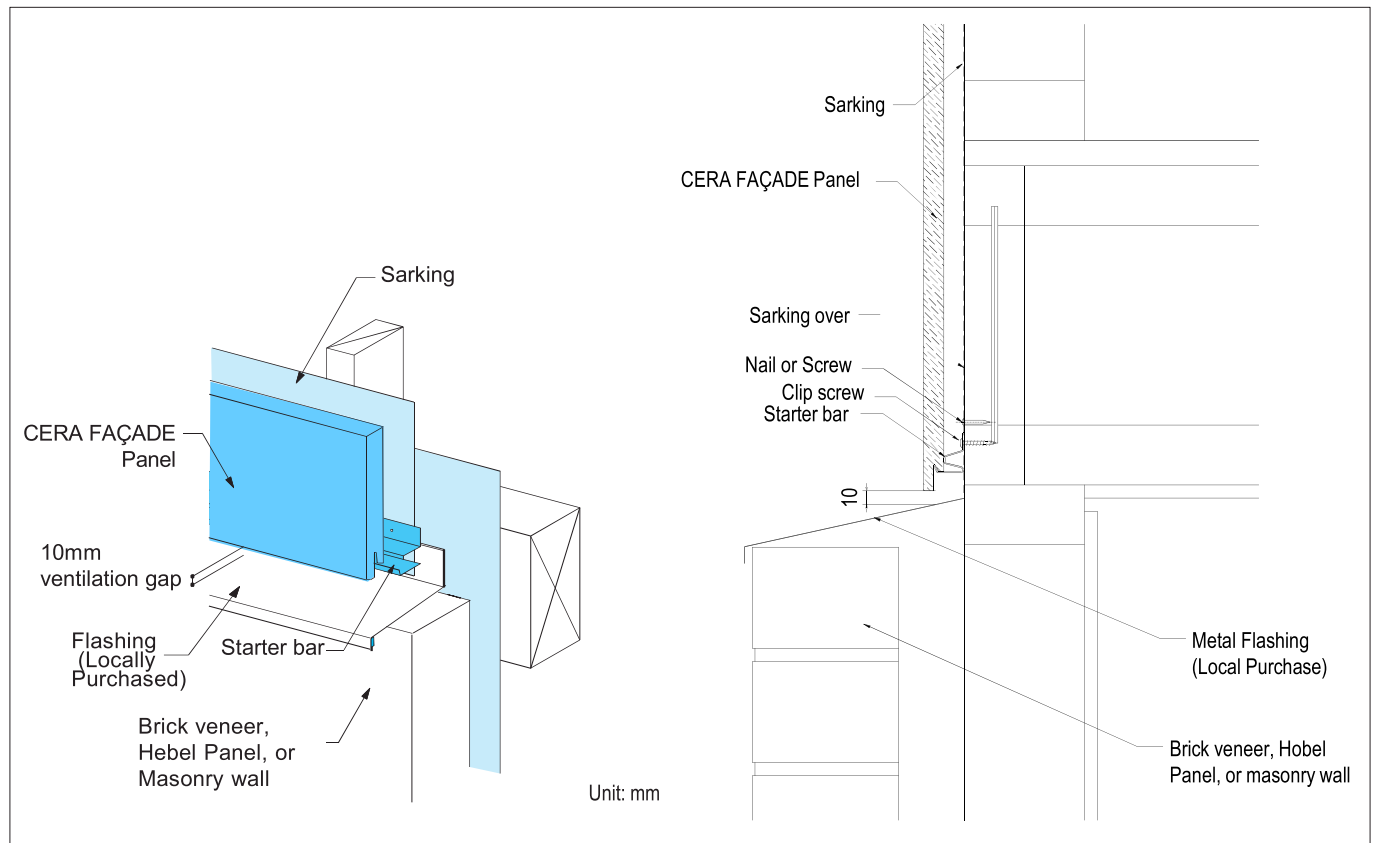

Other details

(2) Side by Side Vertical Junction

- Use a J-channel flashing to separate the CERA FAÇADE Panels and the other material.
- Create a sealant joint between the flashing and the other material.
- Apply sealant (local purchase) after applying a primer specified by the local manufacturer on the surfaces where the sealant is applied.

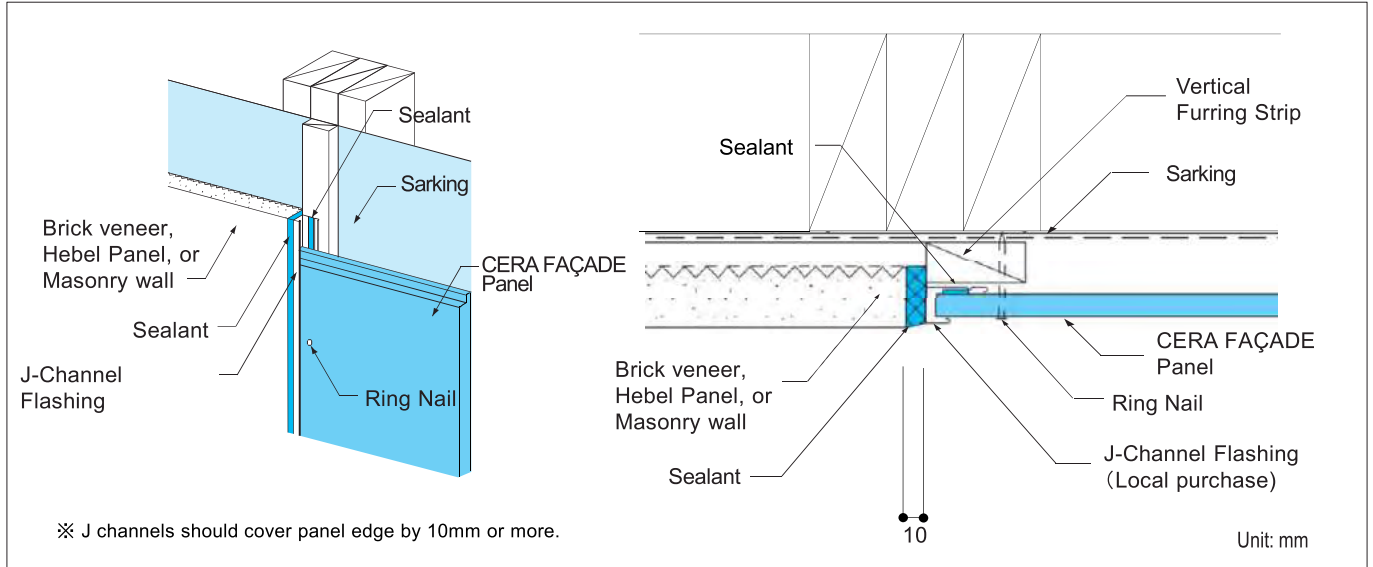

(2) Side by Side Vertical Junction (F product only)

- The Modinex trim may be used to separate the CERA FAÇADE Panels and the other material.
- For the solid core product (16mm, CERA FAÇADE F), Water-Sealing Materials (WSM) is not required to the trim. However, appropriate waterproofing methods should be applied to joints at trims to minimize water in to the cavity as a local common practice as necessary, for which KMEW is not responsible.

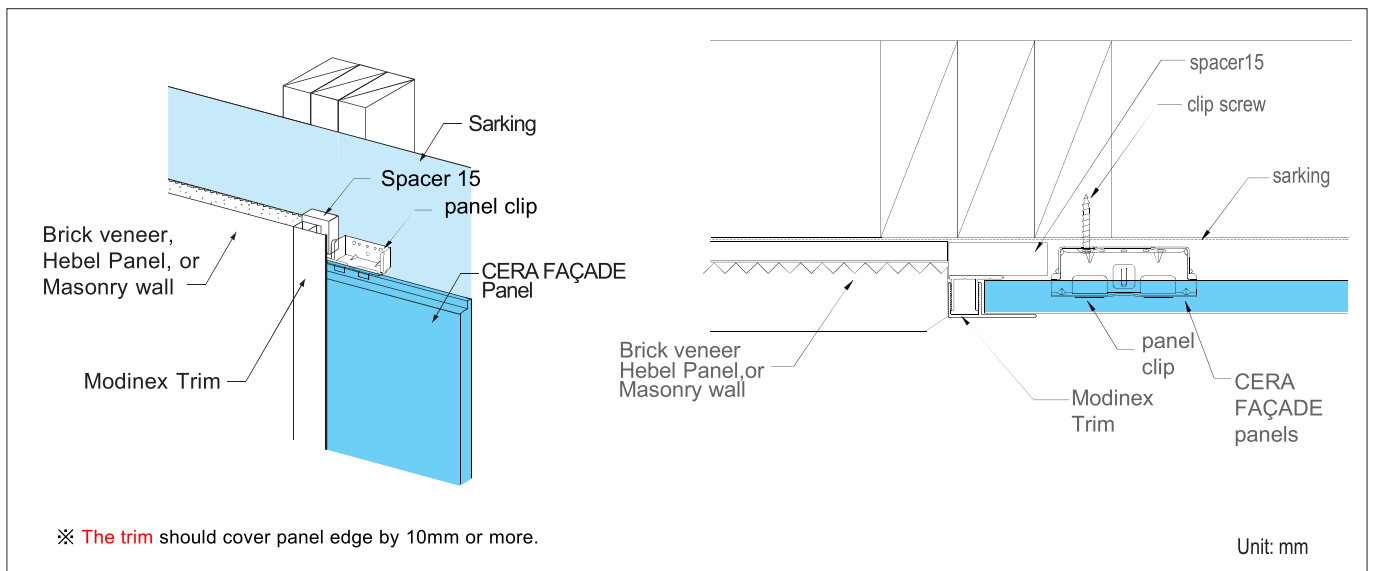

Applying Sealant

1. Standard procedures

- Secure an approx. 10 mm wide, 5 mm deep sealant space in the joints.

1. Check the weather in advance

- Apply sealant on a dry day. Ensure that the target joints are completely dry, especially if the previous day has been rainy or snowy, before starting applying sealant.



4. Attach masking tape

- Attach masking tape along both sides of the joint.



7. Skim the surface

- Skim the surface of the applied compound with a spatula or finger tip to smooth the surface.

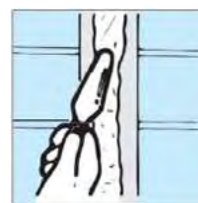

2. Clean the target joints

- Remove any dust, oil, or water from the target joints with a brush or cloth.



5. Apply the primer

- Evenly apply primer to both ends of the CERA FAÇADE panels. Then apply sealant after 30 minutes and before 6 hours since the primer is applied.



7. Remove the masking tape

- Remove the masking tape before the sealant compound gets dry.



If dust, oil, or water remain on the target joints, the sealant compound may fail to adhere and then peel off.

If primer is not applied, the sealant compound may fail to adhere and then peel off.

3. Fill the joints with a backup material

- When using a backup material around openings, provide adequate depth for the joints to be caulked.
- If metal joiners with bond breaker are used, no need to fill the joints with a backup material.



6. Fill the joints with sealants

- Use an appropriate sealant gun. Fill the joints with the sealant compound without gap by using a nozzle that matches the joint width. Take care to leave no air bubbles or gaps.



9. Clean

- Clean off any remaining masking tape, sealant compound and primer.
- This should be conducted after sealant compound gets dry.

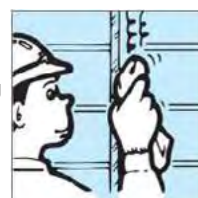

If they are not completely wiped off, discoloration or stains may result.

If dust, oil, or water remain on the target joints, the sealant compound may fail to adhere and then peel off.

If primer is not applied, the sealant compound may fail to adhere and then peel off.

10. Check the finish

- Visually check the sealant finish for uncompleted or uneven sections on the surface, and air bubbles.

If painting is required after applying sealant, carry out painting only after the sealant has completely gotten dry.

Waterproof sealer for uncaulked cut panel edges

- Make sure to apply the specified waterproof sealer to uncaulked cut panel edges to prevent damage due to water absorption and freezing.
- Apply the waterproof sealer to the cut panel edges at the following sections:
 - 1 Sill
 - 2 Intersection with roof
 - 3 Overhang
 - 4 Through wall flashing

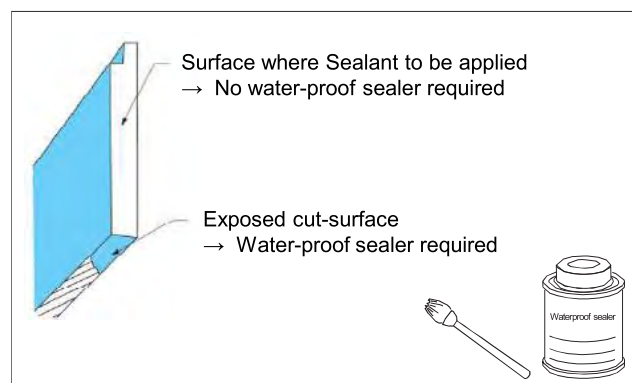
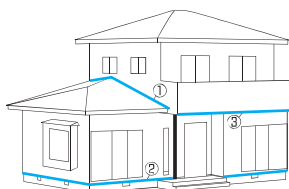

- Protect from fire.
- Seal the container and store it in a dark cold place.
- If the sealer comes into contact with your skin, immediately wash it off with detergent dissolved in water.

Health and safety



Please read before proceeding

- Paint should be finished within the same day of mixing the paint ingredients. If the application cannot be completed within the same day, be sure to finish painting within 24 hours of applying the primer.
- Failure to follow the procedures below can result in poor color matching and may cause repaired portions to discolor over time. Please note that we assume no responsibility for such a case.
- Use no Sealant materials in touch up repairing. Sealant used for touch-up will fade over time.
- Although the solid paint base may appear hard, it will work properly after vigorous mixing with the liquid hardener.
- Please refer to the material identification key to identify the ingredients.

Material Identification Key:



Blue label:
Paint Base











Red label:
Primer



Green label:
Hardener

Follow these directions when applying touch-up paint

<p>1. Preparation</p>	<ul style="list-style-type: none"> • Ensure that the siding surface is completely dry. Avoid painting when it is rainy and wet or the temperature is 5°C or less. • Clean dirty painting portions. <p> Caution: Be sure to finish application within a day, if possible, as both the primer and the paint have a working life.</p>	<p>Touch-up Paint Kit</p>  <p>Paint Base Primer Hardener</p> <p>Brushes</p>
<p>2. Mixing of touch-up paint</p>	<ul style="list-style-type: none"> • Pour the entire bottle of hardener into the base paint bottle. Shake the bottle well. • The mixed paint is susceptible to air humidity; be sure to close the lid tightly after mixing and agitation. • The mixed paint should be used after 30 minutes and within 8 hours of mixing. <p> Caution</p> <ul style="list-style-type: none"> • For best results, mix the entire quantities of the two bottles. Incremental mixing may result in poor performance. • Leave the mixed paint alone for 30 minutes after mixing to stabilize the color tone. • Apply the mixed paint within 24 hours after applying the primer. 	 <p>Paint Base Hardener</p> <p>Hardener</p> <p>Put all of the hardener into the paint base bottle.</p> <p>Paint Base</p> <p>Shake the bottle well until paint color becomes even.</p>
<p>3. Primer application</p> <p>4. Drying</p>	<ul style="list-style-type: none"> • Avoid dripping during application. In case of dripping, remove it immediately with a clean cloth. • The primer is susceptible to air humidity; be sure to close the lid tightly after use. <p> Caution: For best results, apply sparingly.</p> <ul style="list-style-type: none"> • Allow 30 minutes for the primer to dry. 	<p>Brush</p>  <p>Primer</p> <p>Apply the paint carefully to prevent dripping.</p>
<p>5. Application of touch-up paint</p>	<ul style="list-style-type: none"> • The mixed paint should be used after 30 minutes and within 8 hours of mixing. • Use the included brushes to apply the paint without dripping. • Apply the paint over portions applied with the primer. • Apply the paint within 24 hours after applying primer. <p> Caution</p> <ul style="list-style-type: none"> • For best results, use the paint sparingly and cover only the nail head. • Prime all locations before painting. 	 <p>Approx. (7mm)</p> <p>Nail head Paint Primer</p> <p>Application area</p>
<p>6. Inspection</p>	<ul style="list-style-type: none"> • Check for uncoated sections. Paint as needed. 	

Replacing a single panel



Replacement panels must be fastened with nails or screws, rather than clips.

Order	Content of Work	Images
<p>1. Remove</p>	<ul style="list-style-type: none"> Use a utility knife to remove the Sealant. Cut the center of the panel with a power saw and remove the panel. <p>Be careful not to damage the sheathing, waterproof building paper, and adjacent panels.</p>	
<p>2. Prepare the replacement panel</p>	<ul style="list-style-type: none"> Cut and remove the part A (figure, right) of the replacement panel. Without removing this portion of the shiplapped edge the replacement panel will not fit. 	
<p>3. Installation</p>	<ul style="list-style-type: none"> Apply Sealant to shiplapped edges to ensure a waterproof seal. Attach spacer blocks where the panel will be nailed or screwed. Insert the replacement panel. 	
<p>3. Installation</p>	<ul style="list-style-type: none"> Predrill pilot holes and nail or screw the panel into place. Apply touch-up paint to the nail or screw heads. Replace the Sealant where it had been removed. 	

*These repair instructions are only a general guide and additional steps may be required.

After Installation Completion

Wind Class: Installation Completion Checklist (Timber frame)

- N1 N2 For CERA FAÇADE system (KMEW 16mm thick Fiber-cement board with 15mm Clips)
 N3 This checklist should be filled in by the person in charge of installation and be sent to Sumitomo Forestry Australia Pty Ltd.

Building Name		Date	
Building Address			
Builder		Installation Completion Date	
Installation company		Person-in-charge of installation	
CELA CLAD Stock #		Type of application	<input type="checkbox"/> Horizontal <input type="checkbox"/> Vertical

Summary of Building			
Stories of the Building	<input type="checkbox"/> 1 Story <input type="checkbox"/> 2 Stories <input type="checkbox"/> 3 Stories	Height of the Building	() m
Interval of Studs	1F () mm	2F () mm	3F () mm

Installation Checklist		
General	Did you follow the design and installation manual?	<input type="checkbox"/> Yes <input type="checkbox"/> No
Structure (Frame)	Installation ensures the air flow?	<input type="checkbox"/> Yes <input type="checkbox"/> No
	Is the unevenness of the structure on which the sliding panels are installed, less than 2mm?	<input type="checkbox"/> Yes <input type="checkbox"/> No
	Are the widths of the studs for vertical joints sufficient (more than 80mm)?	<input type="checkbox"/> Yes <input type="checkbox"/> No
Installation of CERA FAÇADE Panels	Were specified or recommended accessories (nails, screws, clips, and so on) used?	<input type="checkbox"/> Yes <input type="checkbox"/> No
	For nail direct fastening, were minimum distances from the siding edge maintained and pre-drilled?	<input type="checkbox"/> Yes <input type="checkbox"/> No
	For nail direct fastening, were spacers used?	<input type="checkbox"/> Yes <input type="checkbox"/> No
	Pre-drilled before nailing timber corner cap?	<input type="checkbox"/> Yes <input type="checkbox"/> No
	Was sealer applied on the CERA FAÇADE Panels' cut surfaces to which no sealant is applied?	<input type="checkbox"/> Yes <input type="checkbox"/> No
	Are there scratches, cracks, warping, scum, or swell on the CERA FAÇADE Panels?	<input type="checkbox"/> Yes <input type="checkbox"/> No <input type="checkbox"/> Not Applicable
	Were the panel surfaces wiped in chemicals and solvents (thinner, etc.)?	<input type="checkbox"/> Yes <input type="checkbox"/> No
	Was touch-up paint applied on large areas?	<input type="checkbox"/> Yes <input type="checkbox"/> No
	Were sealant compound used instead of touch-up paints for repair?	<input type="checkbox"/> Yes <input type="checkbox"/> No
	Had the CERA FAÇADE Panels been stored in wet conditions for a long time?	<input type="checkbox"/> Yes <input type="checkbox"/> No
Are there any significant dirt or abrasions on the Panel surfaces?	<input type="checkbox"/> Yes <input type="checkbox"/> No	
Have you checked the Regions of Application in the case of Solid Core?	<input type="checkbox"/> Yes <input type="checkbox"/> No	

Blank for Sumitomo Forestry Australia (SFA) Pty Ltd.	Date of Receipt:	
	Person-in-charge	

