

- Timber
- Aluminium
- Concrete

AUG 2025

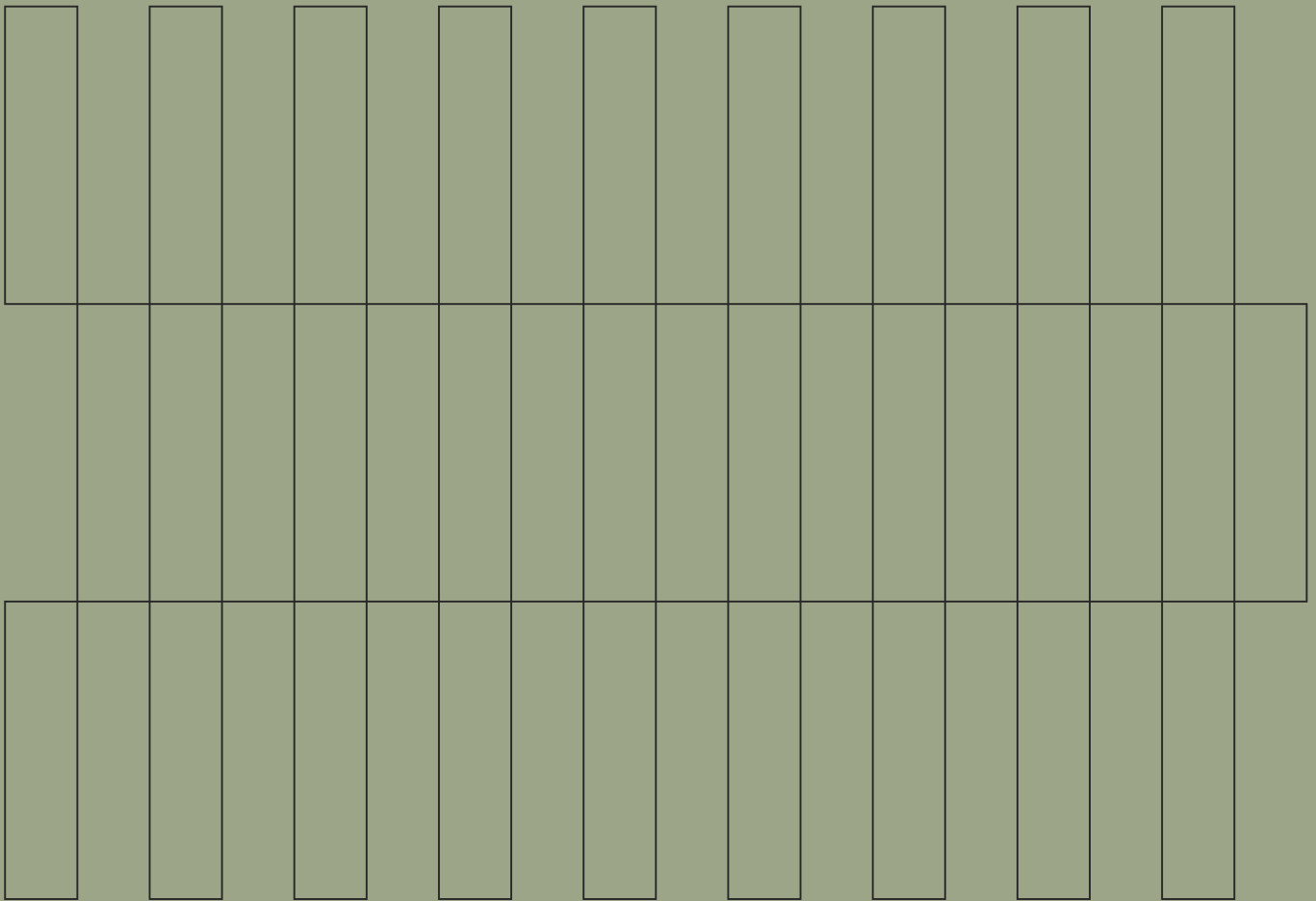

Viroc

Installation Guide

External Cladding Applications

Viroc must be installed using a ventilated cavity system to ensure optimal performance. The installation should include both primary and secondary weather-resistant measures to prevent water ingress. This is achieved by mounting the cladding as a continuous surface over a nominally ventilated and drained wall cavity, with adequate battening and sarking as necessary.

For projects requiring compliance with FP1.4, please contact our team for guidance.

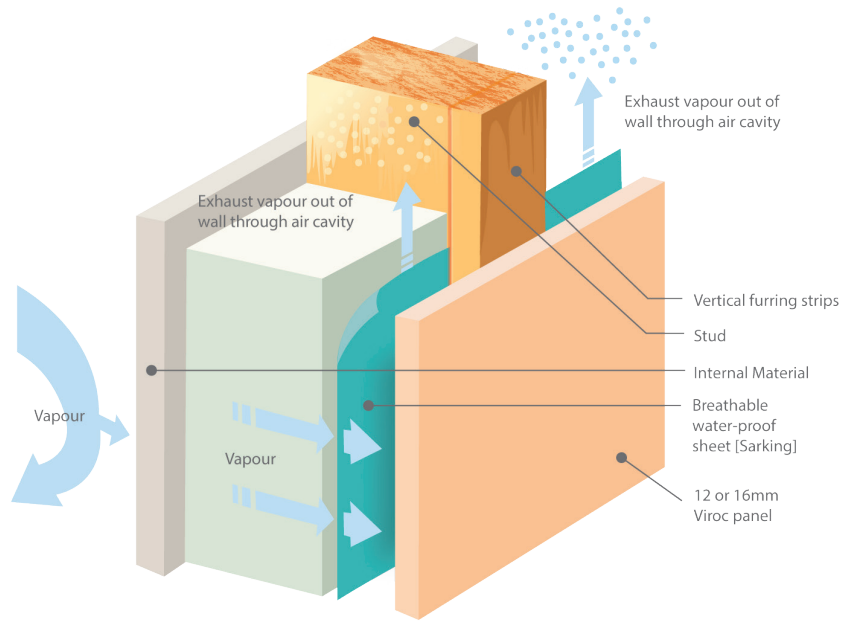

Key points of the rain screen system

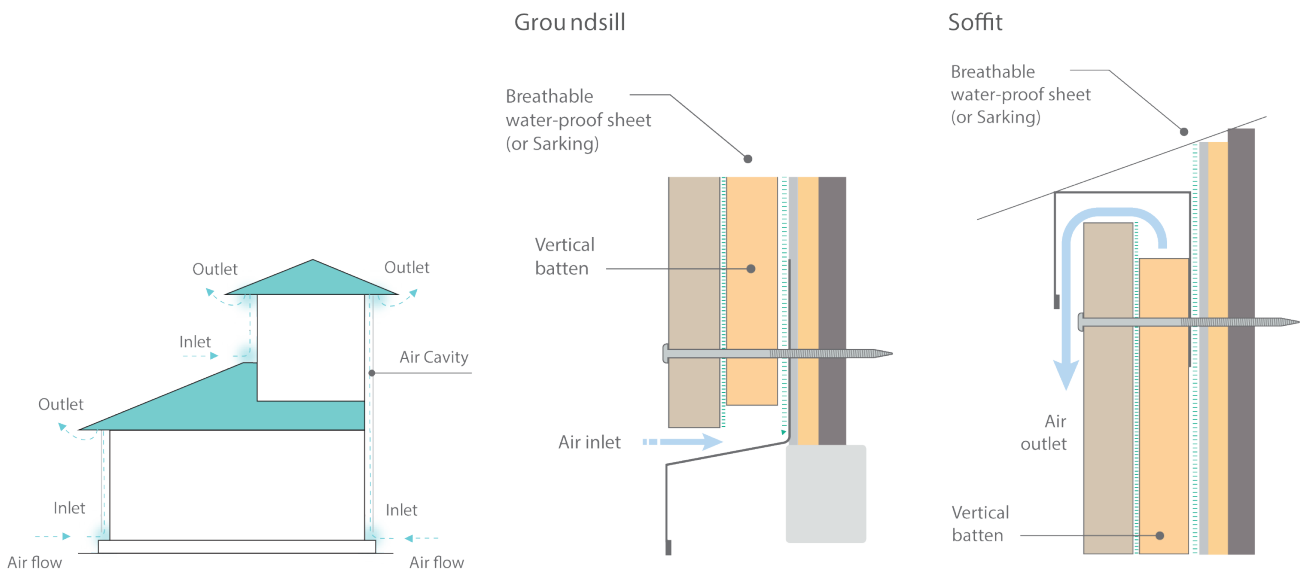

Very Important!



Viroc panels do not contain silica, unlike other alternatives in the market. Using Viroc ensures safe working conditions by eliminating the possibility of inhaling silica dust when drilling, cutting and abrading panels during installation or handling. Harmful effects from inhaling silica can lead to potentially disabling lung diseases like Silicosis.

1. Work outdoors where feasible or use mechanical ventilation.
2. Wear an approved respirator.
3. Warn others in the area.

Handling the Viroc panels

Transporting Viroc panels

- When transporting the panels by vehicle, stack them flat.
- Tie the panels down and cover with plates to avoid damage or shifting when braking.
- Take extra care to avoid damaging panels when loading/unloading.
- When hoisting panels, always put spacers between the panels and ropes or straps to avoid damaging them.
- Do not stack pallets with more panels on top of the pallet than underneath, as this could cause panels to collapse.

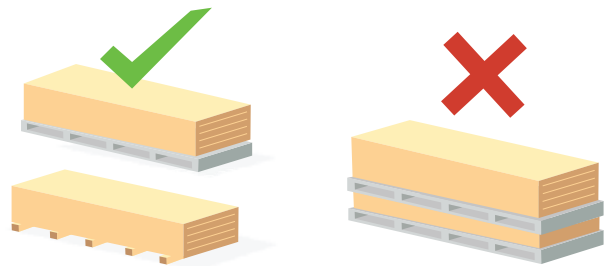

Storage of Viroc panels

- Store panels flat and under cover. Keep the panels dry and off the ground prior to installation to avoid moisture conditions that could affect the quality of the work.
- Panels should not be stacked more than two pallets high and should be loaded with a fork-lift or sling, taking care not to drop the pallet.
- Keep the panels clean when handling on site and take care not to damage the edges.
- If necessary to stand panels on edge prior to installation, take care to avoid rough or abrasive surfaces that could damage the factory-applied coating or sealer.
- Panels should be carried mid-span and on edge for ease of handling and to avoid breakage.

Very Important!

- Carry the panels by holding their lengthwise edges under your arm.
- Take extra care to avoid hitting anything with the panels. Dropping the panels may damage the edges.
- Don't touch the panels with dirty hands.



Surface preparation: Since there are difference in tone between panels from the same batch, before starting a job, the panels should be laid out side by side, arranging them in such a way as to minimize these differences between adjoining panels. Any finish requires prior surface preparation. This preparation consists of polishing/cleaning the surfaces and tops with a cleaning disc or, alternatively, a fine sanding disc with 120 grit or higher.

After polishing/cleaning the surfaces, all residues must be removed with a dry cloth, air blower, or preferably, vacuum cleaner to ensure that they are free of any dust that could compromise the finish.

Necessary Tools

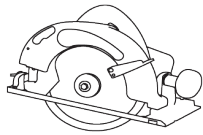

Dust-proof circular saw

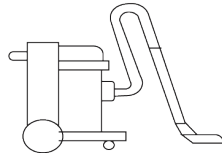

Dust collector

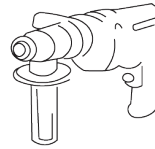

Electric drill/screw driver

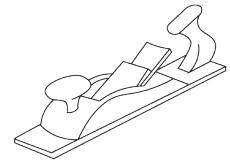

Melamine planer

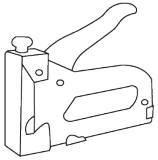

Tacker



Hammer

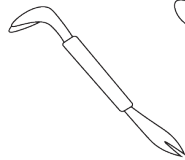

Nail Claw

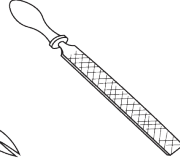

Hand file

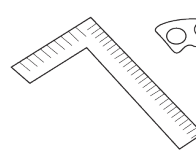

Framing square

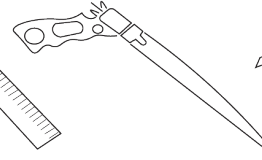

Slate saw

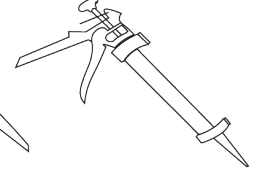

Sealant cartridge gun
Cartridge gun

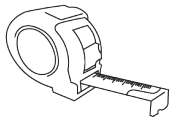

Tape measure

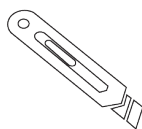

Cutter knife

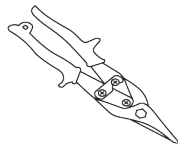

Tin shears



Plumb bob

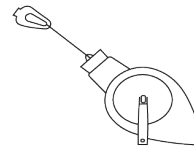

Chalking line

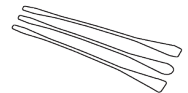

Sealant spatulas

Installation Order

Timber frame/steel frame with clips (15mm)

1. Check the frame

2. Install sill flashing

3. Install waterproof breathable sheet

4. Marking

5. Install accessories (outside & inside corners, vertical joints, etc.)

6. Measurement

7. Cut

8. Fasten sliding panels

9. Touch up & paint inspection

10. Sealant

Panel set-out

- When laying out the panels, take into consideration the appearance of the building, the length of provided accessories and how to minimize material waste.
- Layout express joint in advance to create an aesthetically pleasing finish.
- Include the inside dimension of the pre-formed outside corners in consideration of panel arrangement.
- Vertical joints should be aligned with studs.
- Include the sealant joint width (10mm) for each vertical joint.
- Pay attention to window locations and eave soffit height to provide more than 150mm max for the panels above and below window frames (B, C, figure below right) and panels below the soffit (A).
- Avoid installing less wide panels in these locations.

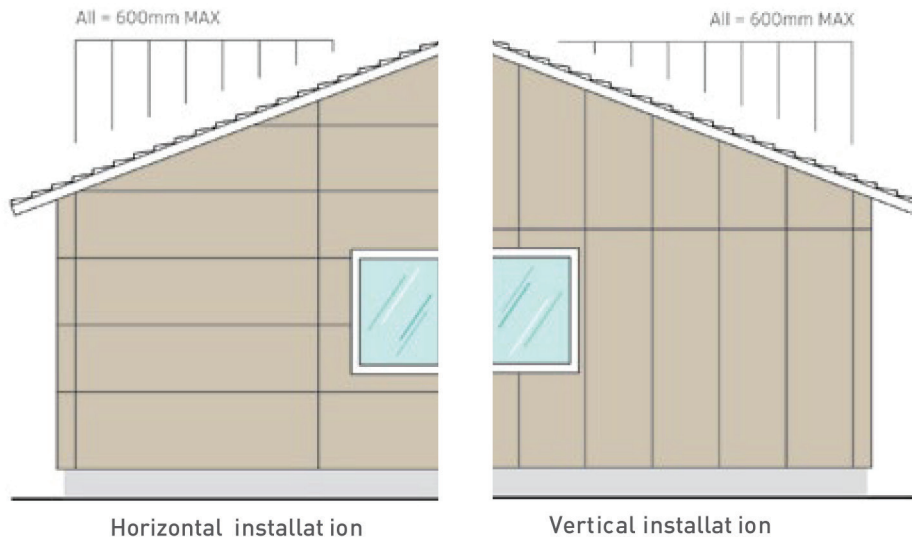

Sheets are 1250x3000mm in 12mm thickness. Refer to fixing diagram 60 mm max.

Panel set-out

Viroc panels have been tested and results reported by Summermore Pty Ltd. to the requirements of:

- AS/NZS 1170.0
- AS/NZS 1170.1
- AS/NZS 1720.1
- AS 1684

Wind Loading	Speed	Equivalent from Test Data
Low	→ 32m/s	N1, N2
Medium	37m/s	C1, N3
High	44m/s	C2, N4
Very High	50m/s	C2, N4
Extra High	55m/s	C2, N4
Specific Design	→ 55m/s	Engineer designed

As wind zones in NZS 3604 are a simplified method of calculating wind action based on AS/NZ 1170.2, it is recommended that fixing testing data is made readily available to suitably qualified engineers for Specific Design.

Testing data shows suitable fixing details for wind speeds up to 60m/s (C3), which is outside the scope of NZS 3604.

Viroc has been certified by Summermore Pty Ltd. to meet and generally exceed the requirements of NZS 1170.5 (Earthquake Actions in New Zealand).

Check the frame

Timber frame

Check that the frame is set out to accommodate wind loading, services and openings. Allow for 35mm battening and flashing plus.

- Carefully place spacers so as not to block the ventilation holes behind the eave flashing.
- Check flashing is horizontal with a level.
- Fix the flashing with nails or screws at intervals of 600mm or less.

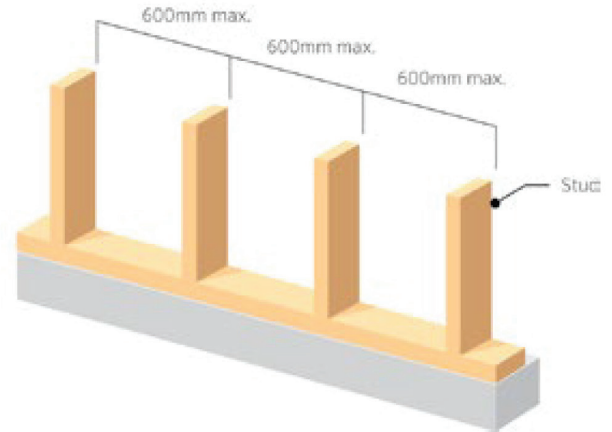
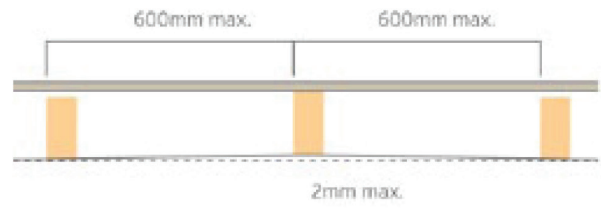

- A:**
Should meet National Construction Code (NCC) 2016 Volume Two, 3.1.2.3 Surface water drainage [b] slab-on-ground - finished slab heights:
1. 50mm or more
 2. 100mm or more
 3. 150mm or more.

- B:**
1. 30mm or more
 2. 80mm or more
 3. 130mm or more.

- C:**
1. Paved concrete areas
 2. Low rainfall intensity, sandy, or well-drained areas
 3. Any other areas.

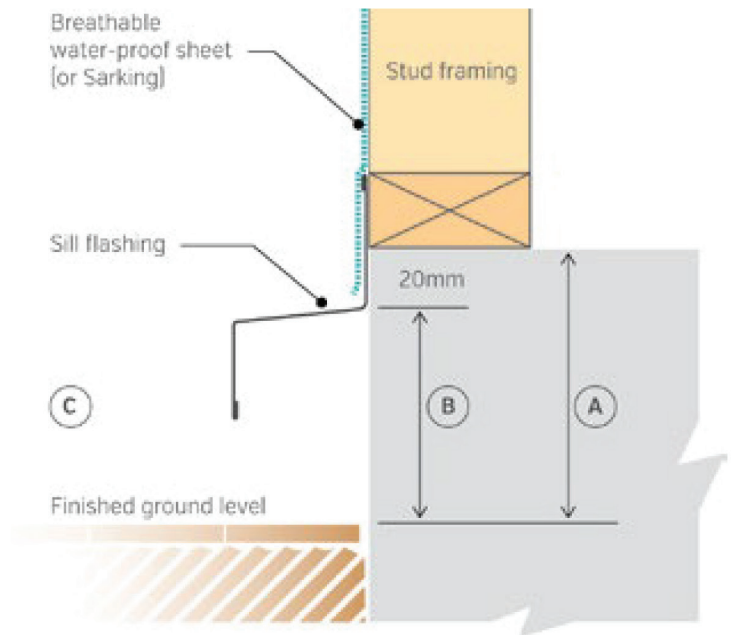

Check the frame

Timber frame

Vertical panel installation shown below. Allow for batten ventilation for horizontal batten runs.

- Carefully place spacers so as not to block the ventilation holes behind the eave flashing.
- Check flashing is horizontal with a level.
- Fix the flashing with nails or screws at intervals of 600mm or less.

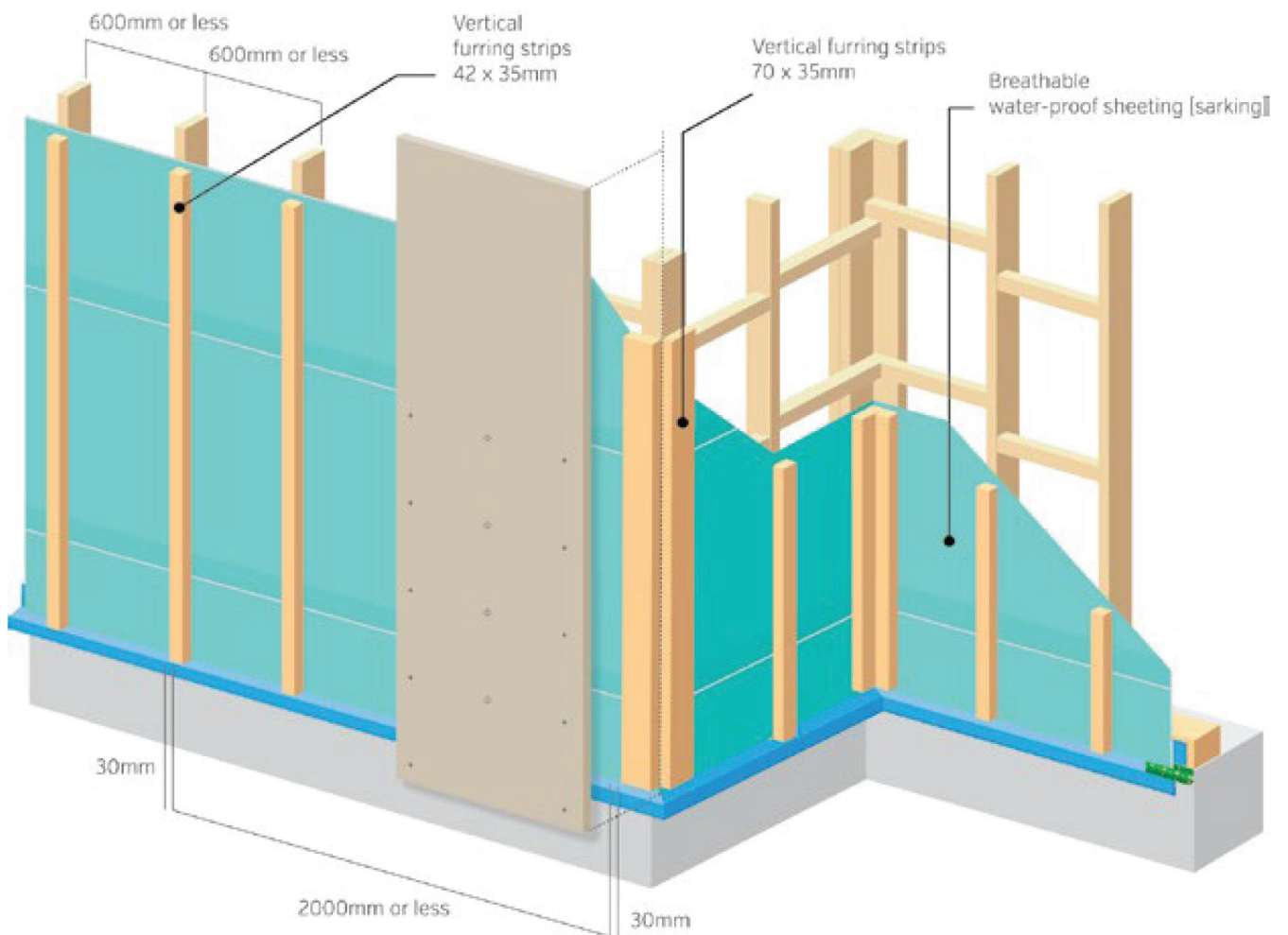

Check the frame (continued)

Steel frame

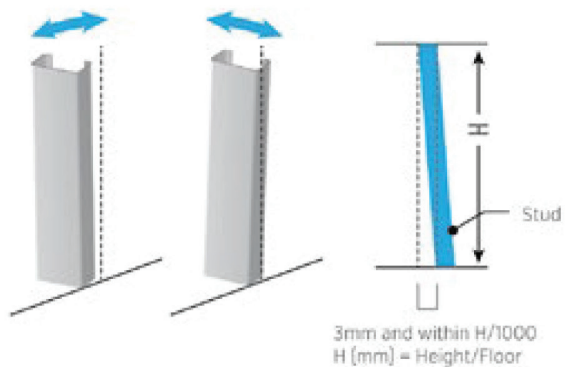

A. Frame vertical unevenness

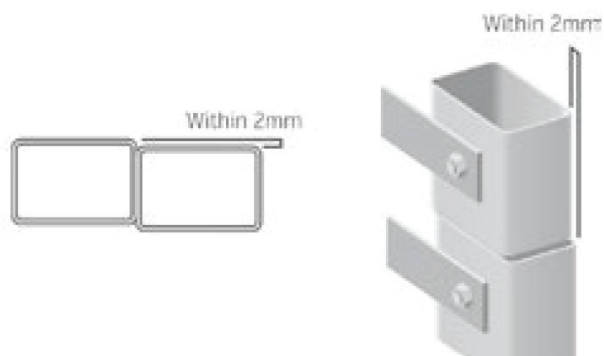

C. Stud unevenness

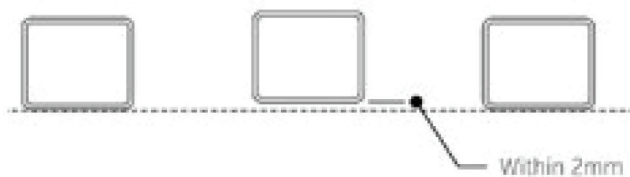

B. Eye height unevenness



D. Screw heads & sash frame fringe

Check the frame (continued)

Timber frame

Note that fixing are required as per generic certification and wind loads.

The maximum dimension of the Viroc panel, when applied on a metallic structure is 1500 x 1250mm

#10 Viroc 12mm

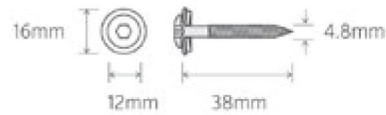

#12 Viroc 12 and 16mm

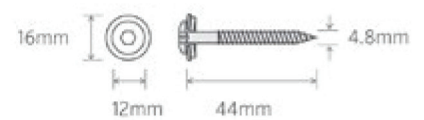

Horizontal Isolation

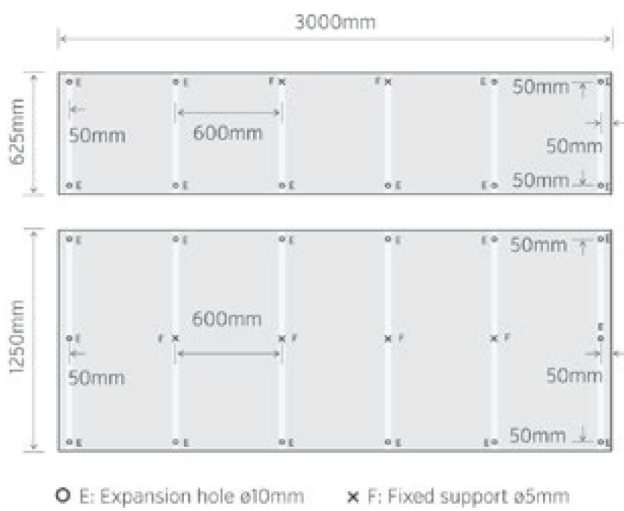

Vertical Installation

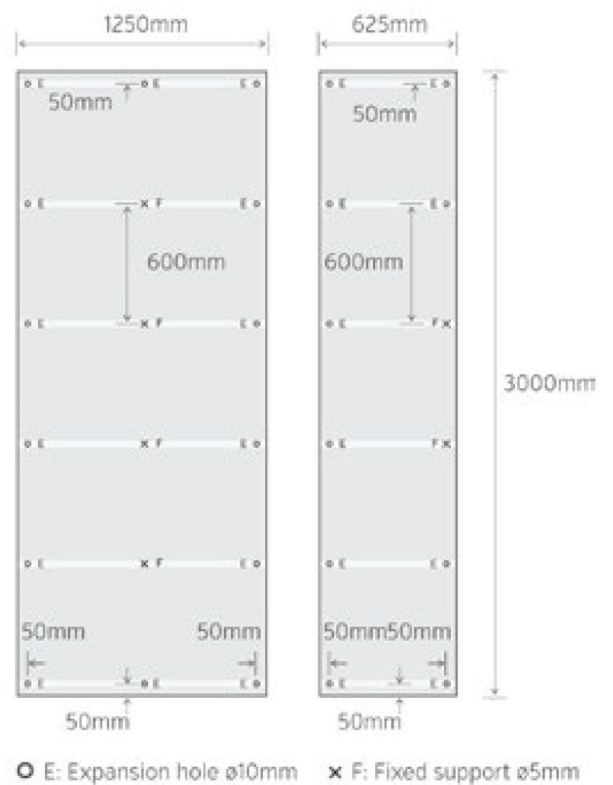

Fixing details

Timber Frame

Facade

- The screws for fastening Viroc to a timber structure shall be made of stainless steel of class A2 minimum with a body diameter of 4.8 mm and a 16 mm head. A neoprene washer should be fitted to control the clamping force. Screws with lower head diameter may be used provided they are fitted with a 16 mm diameter metal washer with neoprene. The length of the screw must be sufficient to match the thickness of the board, plus approx timber penetration depth of 22 mm
- 12G x 38mm Zinc Plated Countersunk Head Wood Screws/ or longer to suit

Flooring

- When the support structure is made of timber, the screws should have a minimum anchoring length (depth embedded in the timber) of 30mm.
- 12G x 38mm Zinc Plated Countersunk Head Wood Screws/ or longer to suit

Ceiling

- 10 mm in dry indoor areas; 12 mm in exterior areas or humid indoor areas, such as bathrooms and kitchens.

Wall

- The screws for fastening Viroc to a timber structure shall be made of stainless steel of class A2 minimum with a body diameter of 4.8 mm and a 16 mm head. A neoprene washer should be fitted to control the clamping force. Screws with lower head diameter may be used provided they are fitted with a 16 mm diameter metal washer with neoprene. The length of the screw must be sufficient to match the thickness of the board, plus approx timber penetration depth of 22 mm
- 12G x 38mm Zinc Plated Countersunk Head Wood Screws/ or longer to suit

Ceiling Fixing Recommendations				
Thickness	Maximum dimension of panels	Hole Dimension		Screw
		Fixed Point	Sliding Point	
12	3000 x 1250	5mm	10mm	TW-S-D16-4.8x38 + Washer Torx Panel Bolts TB16 4.8x38 A16 TW-S-D12-S16-4.8x38 Torx Panel Bolts TB12 4.8x38 A16
16	3000 x 1250	5mm	10mm	TW-S-D12-S16-4.8X44 TW-S-D12-S16-4.8X60 Torx Panel Bolts TB12 4.8x60 A16

Fixing details

Steel Frame

Facade

- Bimetal screws should be used, with stainless steel body and carbon steel drill tip. The diameter of the head shall be 16 mm and the body at least 5.5 mm. Smaller head diameter screws may be used provided they are fitted with a 16 mm diameter metal neoprene washer. The length of the screw must be sufficient to match the thickness of the board with that of the metal profile
- 10g x 35mm wing tip galvanised screws/ or longer to suit

Flooring

- 10G x 35mm Wing Tip Galvanised Screws/ or longer to suit

Ceiling

- 10 mm in dry indoor areas; 12 mm in exterior areas or humid indoor areas, such as bathrooms and kitchens.

Wall

- Bimetal screws should be used, with stainless steel body and carbon steel drill tip. The diameter of the head shall be 16 mm and the body at least 5.5 mm. Smaller head diameter screws may be used provided they are fitted with a 16 mm diameter metal neoprene washer. The length of the screw must be sufficient to match the thickness of the board with that of the metal profile
- 10g x 35mm wing tip galvanised screws/ or longer to suit

Ceiling Fixing Recommendations				
Thickness	Maximum dimension of panels	Hole Dimension		Screw/Rivet
		Fixed Point	Sliding Point	
12	3000 x 1250	5mm	10mm	SW3-12-L12-S18-5.5x32 STARCOLOR/Za 5.5x38 A16 DRILLMOX STAR 5.5x38 A16 AP15-5.0x21 RIVET N.E CEL Alu/nox-4.8x22
16	3000 x 1250	5mm	10mm	SW3-12-L12-S18-5.5x42 STARCOLOR/Za 5.5x38 A16 DRILLMOX STAR 5.5x50 A16 AP15-5.0x21 RIVET N.E CEL Alu/nox-4.8x22

Fixing details

Aluminium Frame

Facade

- Due to the high coefficient of expansion, aluminium structures cannot be used.

Flooring

- Due to the high coefficient of expansion, aluminium structures cannot be used.

Wall

- Due to the high coefficient of expansion, aluminium structures cannot be used.

Standard Flashings and Trims

The section of the profiles is generally T/L/Y- shaped with a minimum thickness of 2 mm. Other section shapes may be used, provided they have equal performance and durability. T-shaped profiles are used at the intersection of 2 boards. L-profiles are used as intermediate supports and edge trims, and Y Profiles are used to make singular points of the façade, as in the case of an external (convex corner)

Edge Trims

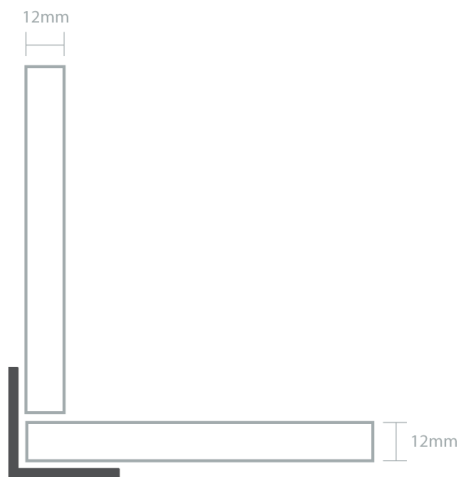

Y Angle

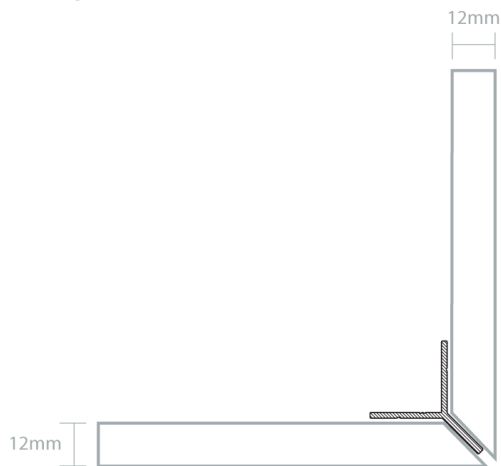

Express Joints

- Ensure front, back and all edges/cut edges of the board are sealed prior to installation. This will limit the effects of any water that does manage to get behind the boards
- Ensure a bead of sealant is run in the corner of the trim, where the boards overlap the trim. This will create a permanent waterseal along the top/ bottom edges
- Ensure all joins in the express trim are properly sealed and secured.

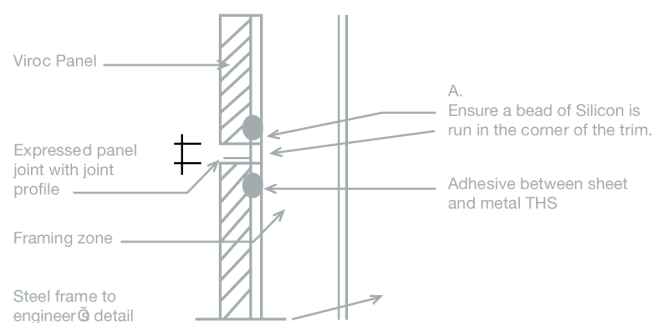

Board fastening

Wall runs vertical and horizontal

1. Framework.
2. Sarking.
3. Timber batten.
4. Join profile.
5. #10 Specified screw.
6. 12mm Viroc panel.
7. Weather-proof strip.

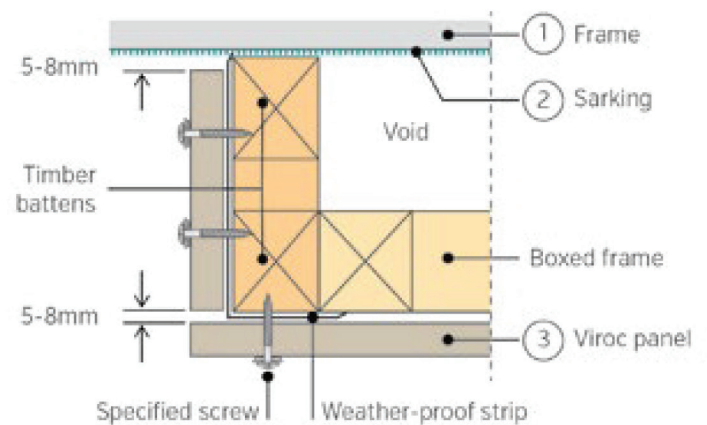
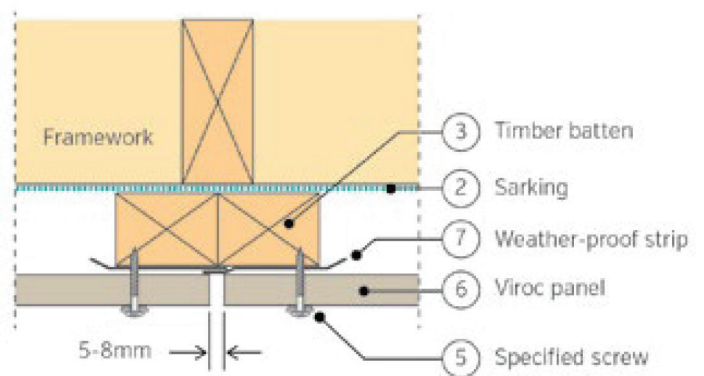
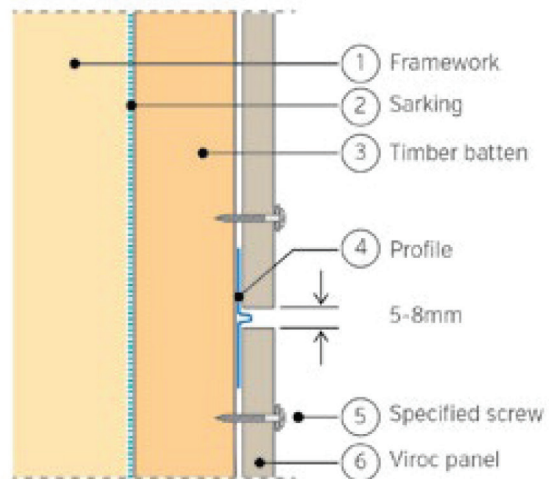

Returns

1. Framework.
2. Sarking.
3. 12mm Viroc panel

Board fastening (continued)

Internal corners

1. Weather-proof strip.
2. Internal corner profile.
3. #10 specified screw.
4. 12mm Viroc panel.
5. Sarking.

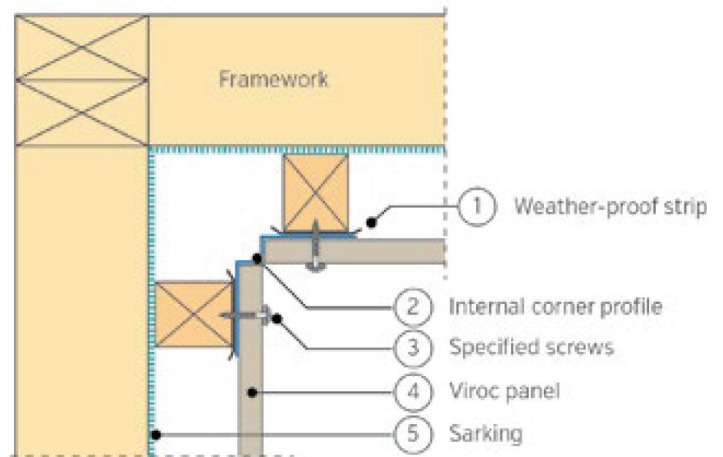

External corners

1. 12mm Viroc panel.
2. Weather-proof strip.
3. Timber batten.
4. #10 specified screw.
5. Angled flashing.

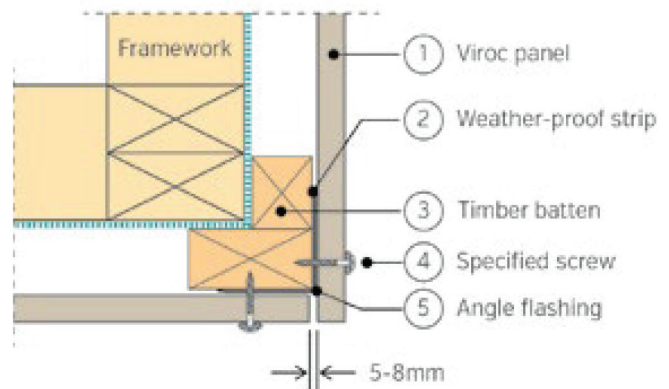

Option 1

1. 12mm Viroc panel.
2. Weather-proof strip.
3. Timber batten.
4. Angled flashing.
5. #10 specified screw.
6. External corner profile.

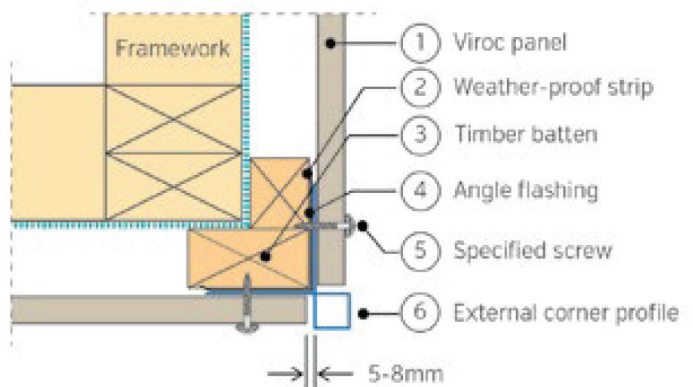

Option 2

Board fastening (continued)

Window Jamb board detail

1. Window frame.
2. 2-piece end profile.
3. Double-sided waterproof tape.
4. Timber batten.
5. Waterproof sarking.

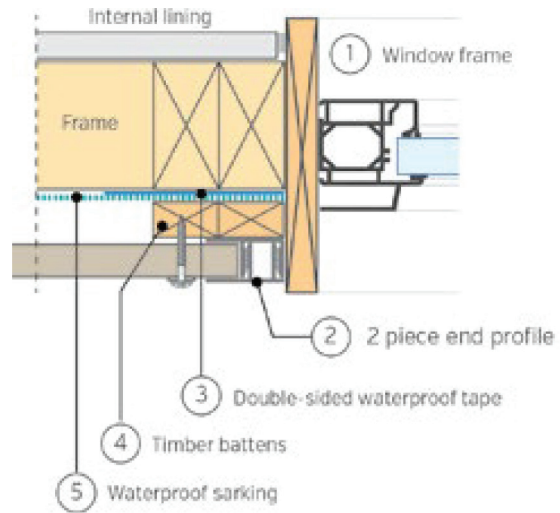

Horizontal break between storeys

1. 12mm Viroc panel.
2. Weather-proof strip.
3. #10 specified screw.
4. Flashing.
5. Timber battens.
6. #12mm floor.
7. Joist(250-300mm)

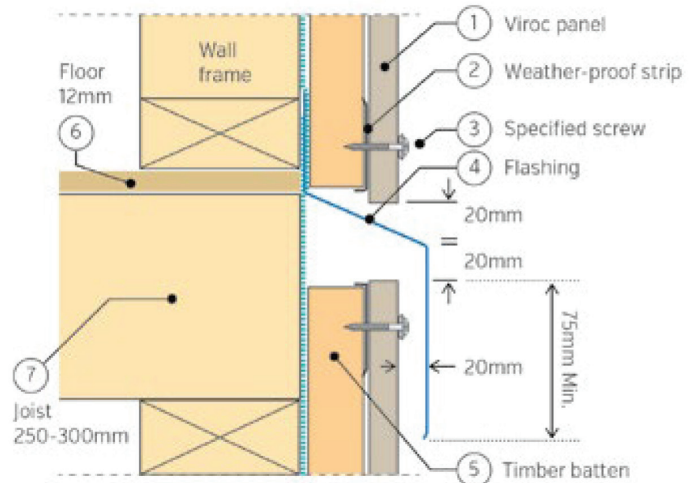

Parapets

1. Cover flashing.
2. Packing strips.
3. #10 specified screw.
4. Weather proof strip.
5. Sarking.
6. Timber battens.
7. 12mm Viroc panel.

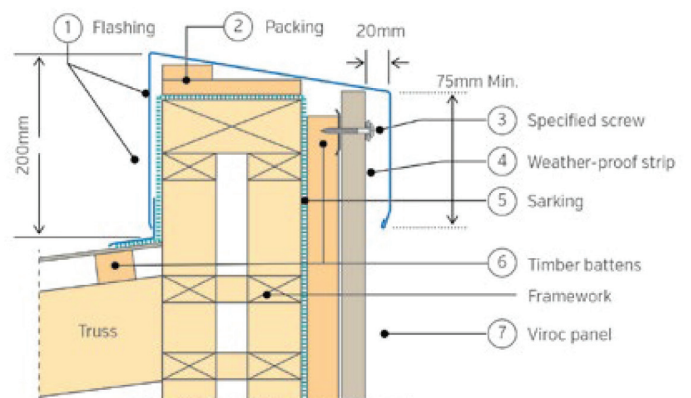

Board fastening (continued)

Ground detail

1. 12mm Viroc panel.
2. Timber batten.
3. Sarking.
4. #10 specified screw.
5. Copy to be provided.
6. Copy to be provided.

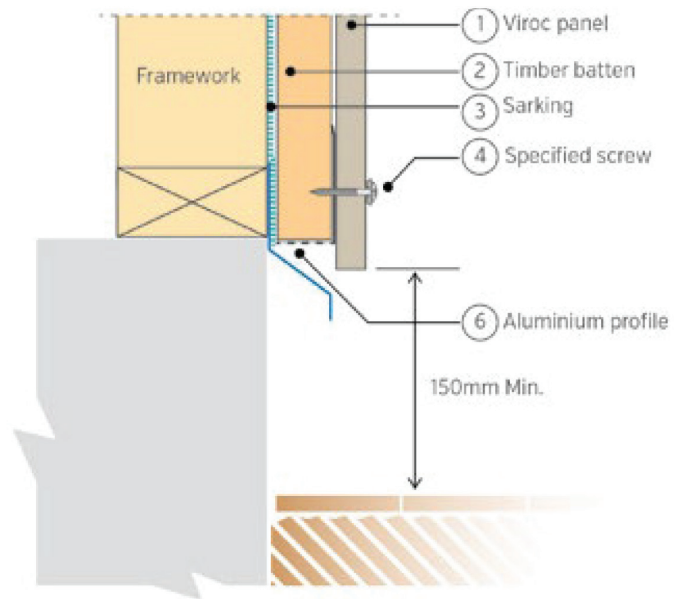

Lintel Section

Ground detail

1. 12mm Viroc panel.
2. Timber batten.
3. Z flashing.
4. #10 specified screw.
5. Sarking.
6. Sill flashing.

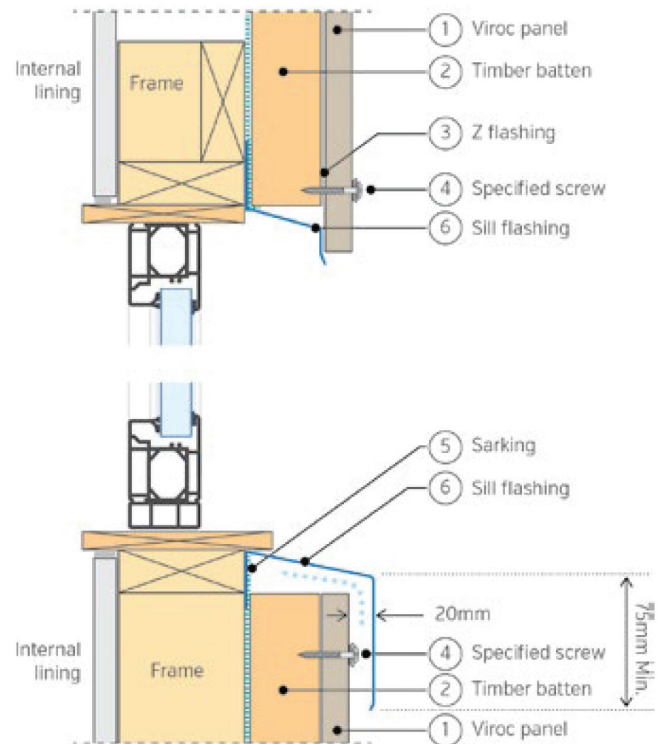

Board fastening (continued)

Termination detail

1. Right angle flashing.
2. Specified screw.
3. Weather-proof strip.
4. Timber batten.
5. Sarking.
6. Framework.

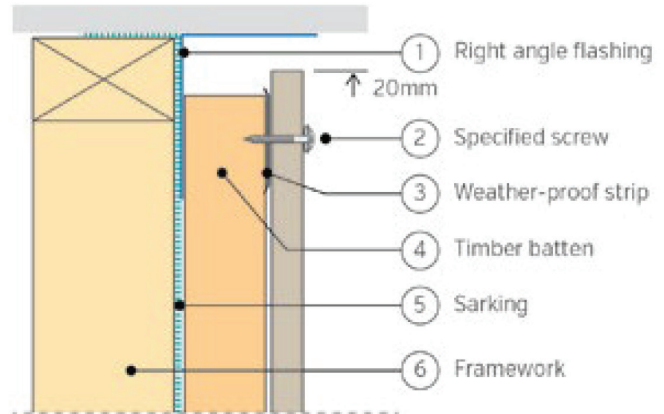

Material change or alternative storey break

1. 12mm Viroc panel.
2. Weather-proof strip.
3. #10 specified screw.
4. Aluminum profile.
5. Timber battens.

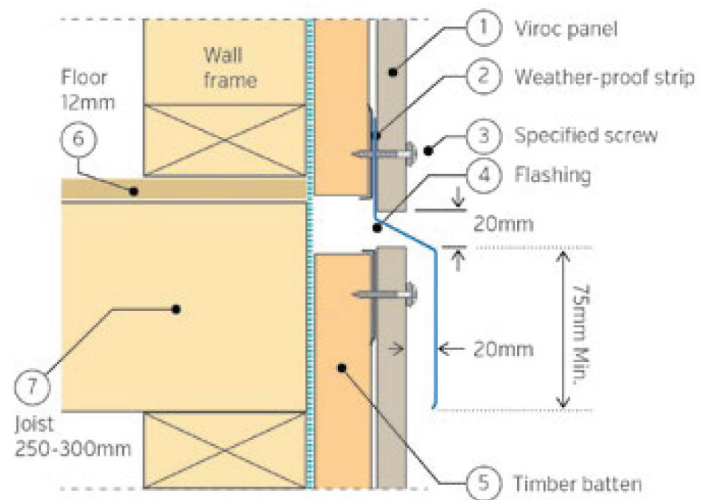

Applying Sealant

Please note:

For External Use

1. Seal front and back before installation.
2. Once in place, seal front face with the sealant.

For Internal Use in wet areas

1. Seal front and back before installation.
2. Once in place, seal front face with the sealant.

For Internal Use in wet areas

1. Seal front and back before installation.
2. Once in place, seal front face with the sealant.

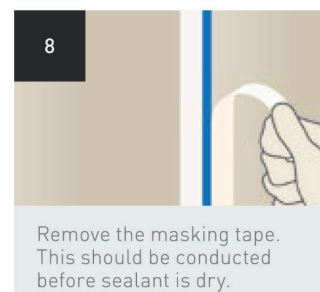
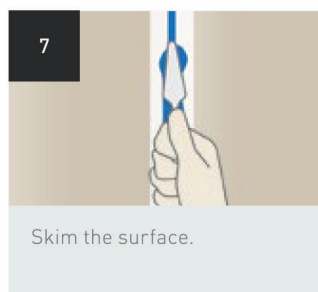
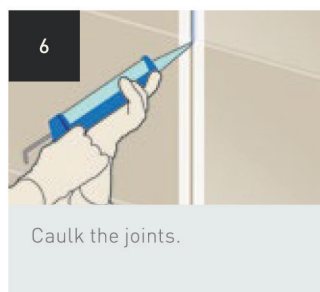
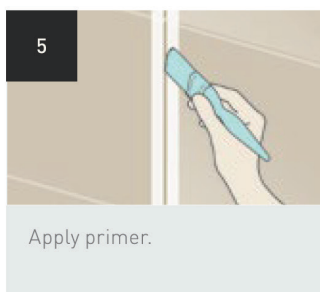
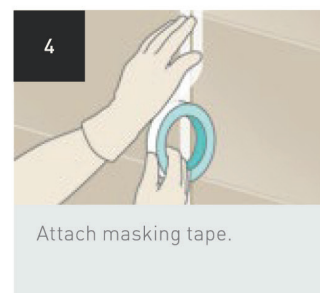
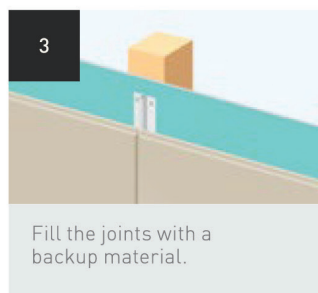
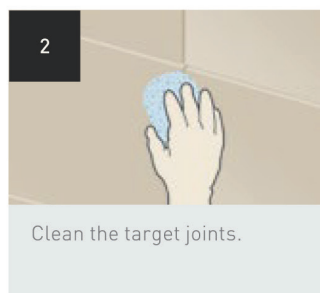
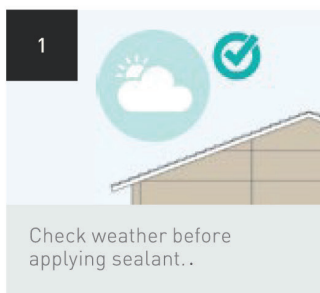

Note:

No need to fill the joints with a backup material if metal joiners with bond breaker are used.

Fastening

Board fastening

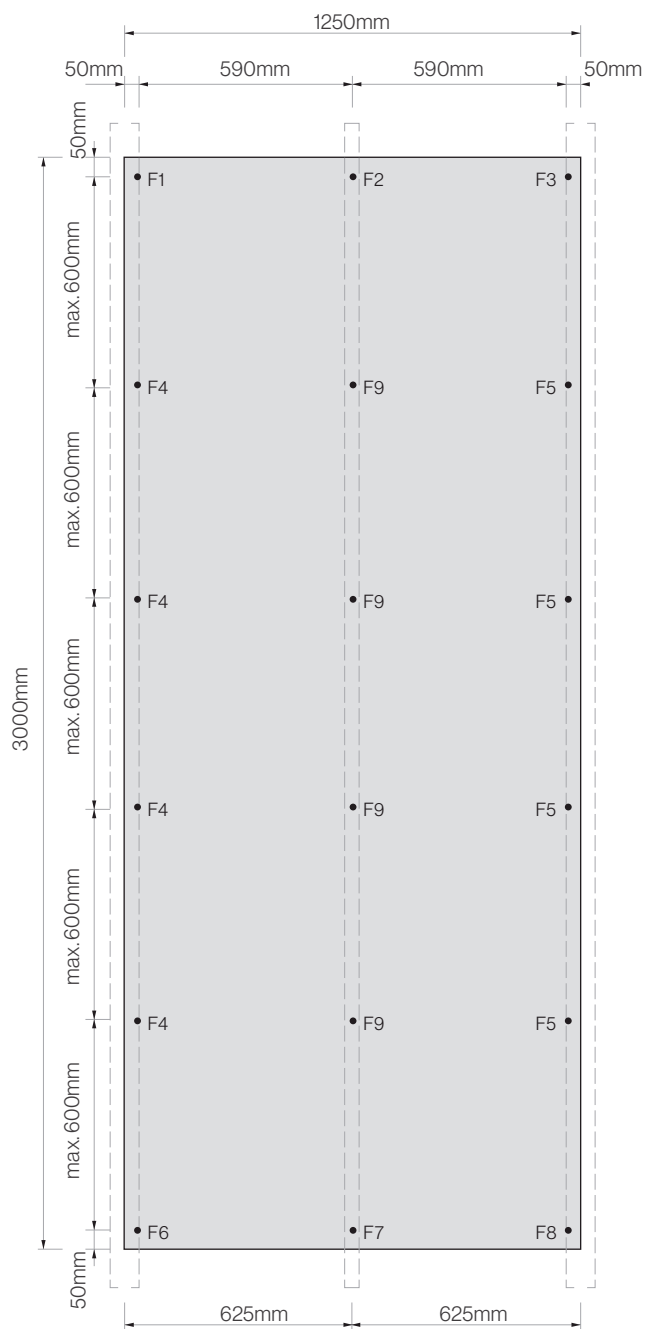

Distances to edges

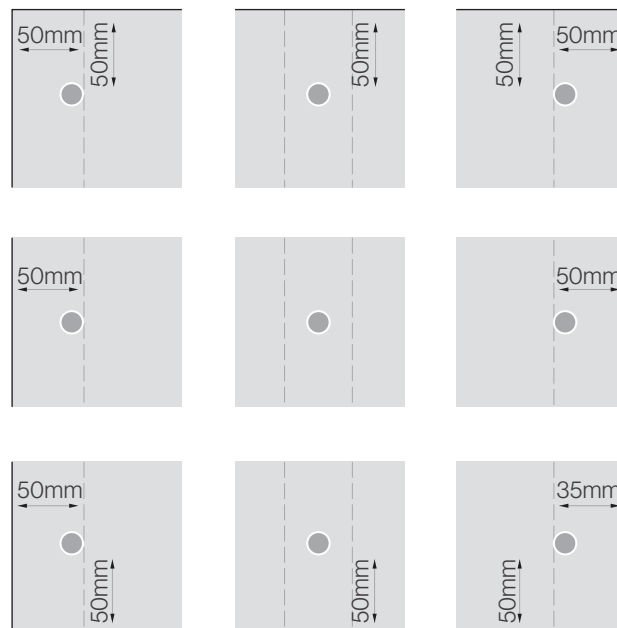

Fastening to steel structures

IMET C8-4.2x32

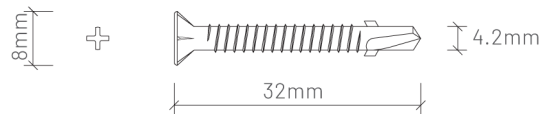

Rivet C16-5x21

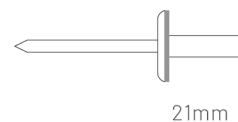

Alternative screws for metallic structures

EMET V12-A16-5.5x32

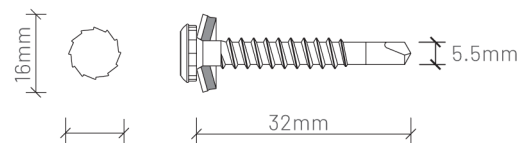

EMET C14-A16-5.5x50

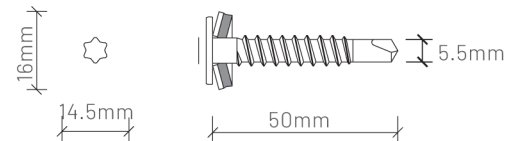

Internal Wall Cladding (continued)

Fastening to timber structures

IMAD C12-5.5x38

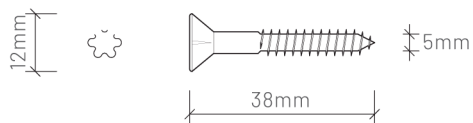

NAIL 1x35



Alternative screw for wood structure

EMAD C12-A16-4.8x38

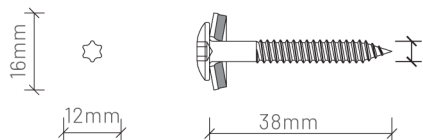

Profiles

Steel

Prole thickness should be 1mm minimum, galvanized according to Standard EN10326 Class Z 275 minimum.

Prole U90 - 42x90x42

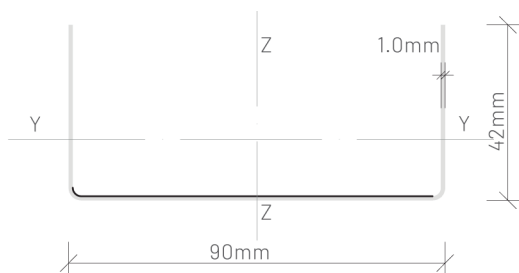

Prole U45 - 42x45x42

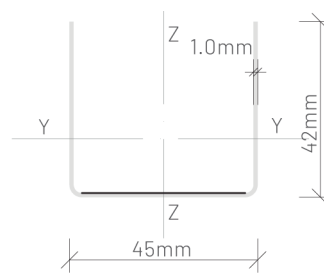

Prole Omega45 - 25x40x45x40x25

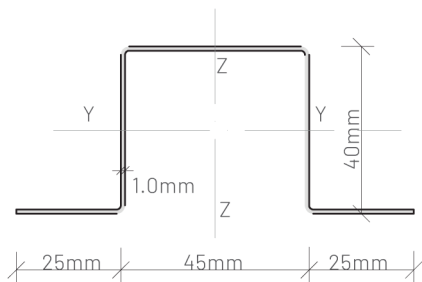

Wood

Class resistance C18 according to Standard EN338.

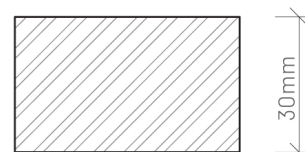
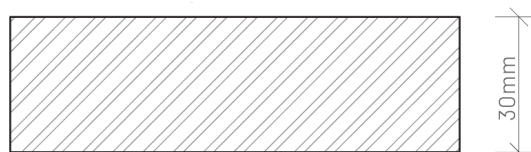

Internal Wall Cladding (continued)

Support structure

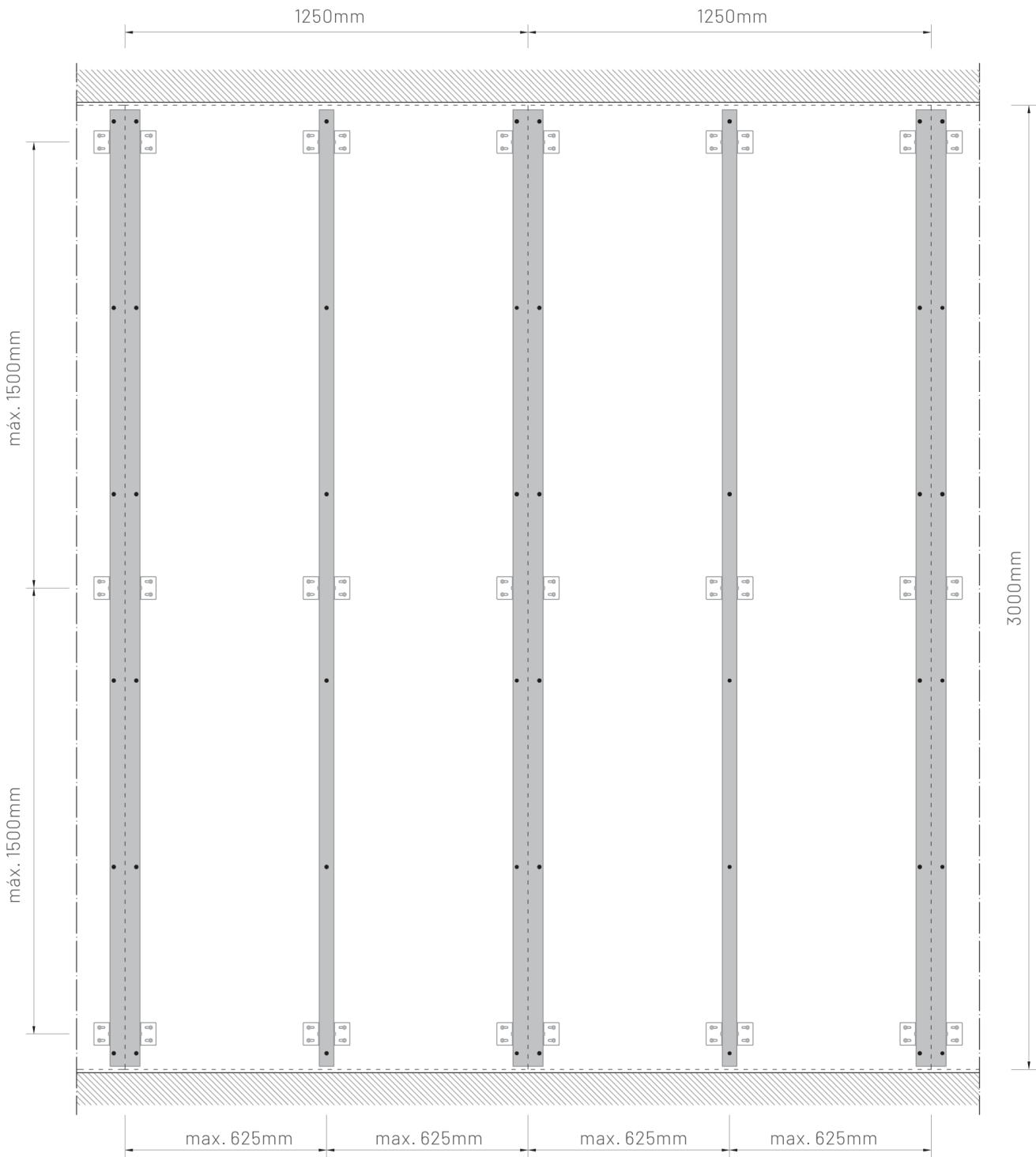

Internal Wall Cladding (continued)

Horizontal sections

Steel structure

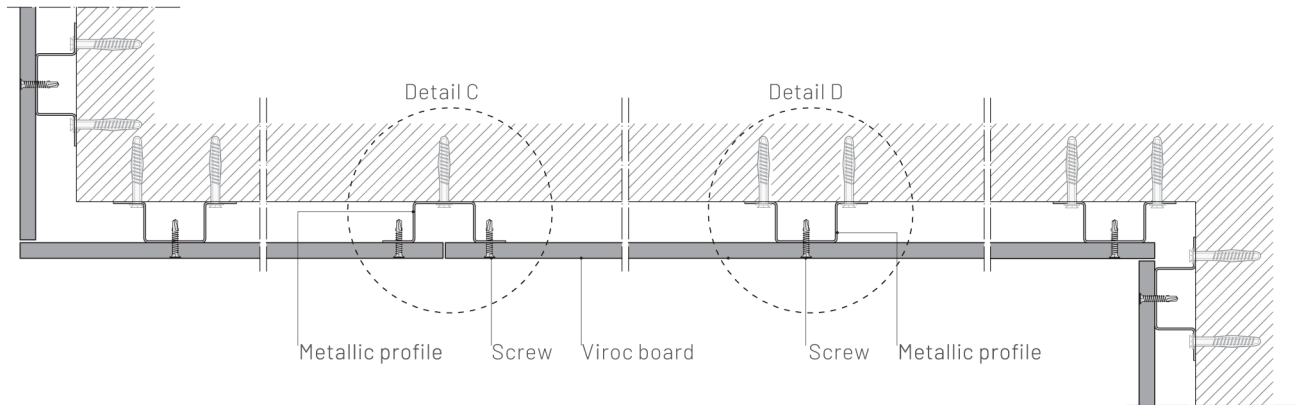

Steel structure (alternative)

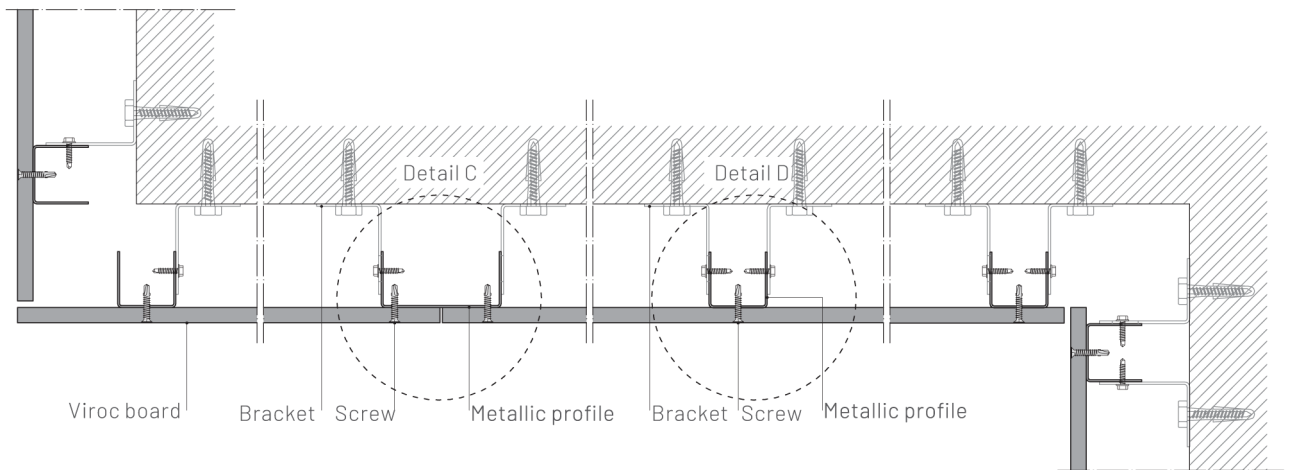

Wood structure

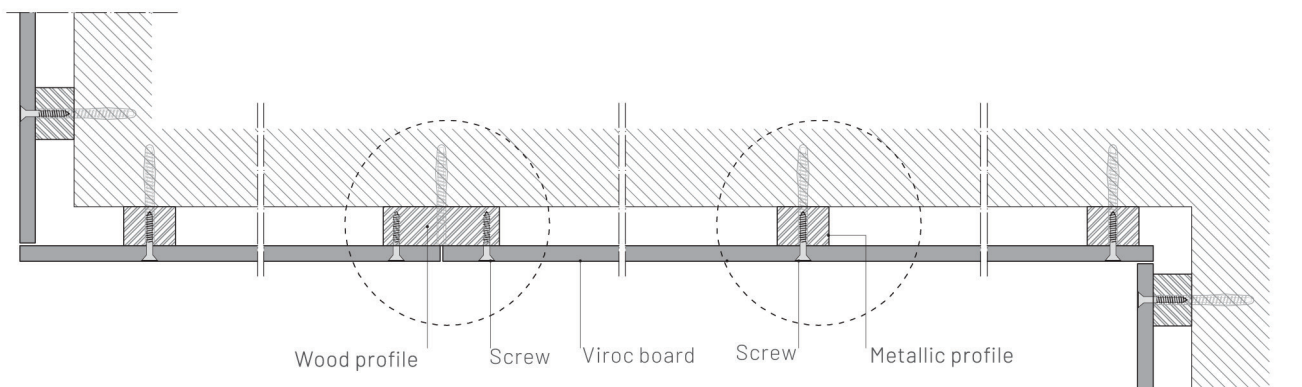

Internal Wall Cladding (continued)

Detail A (steel structure)
Joints between boards

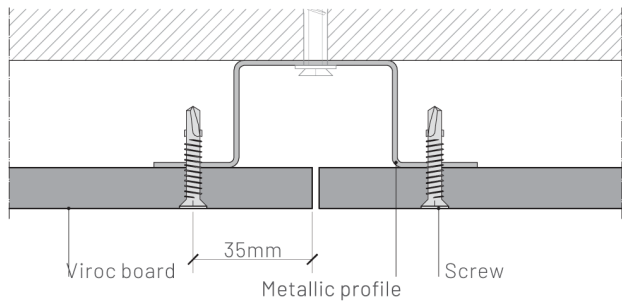

Detail B (steel structure)
Board central zone

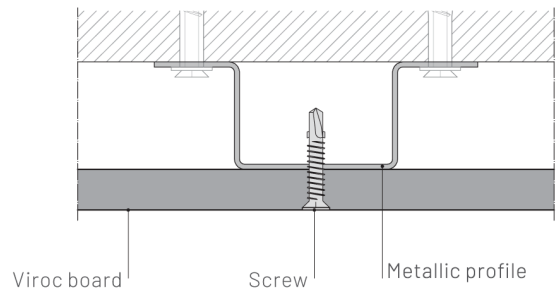

Detail C (steel structure, alternative)
Joints between boards

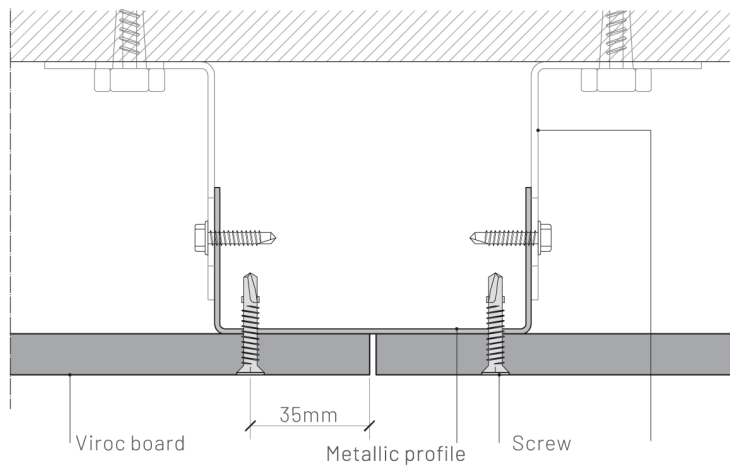

Detail D (steel structure, alternative)
Board central zone

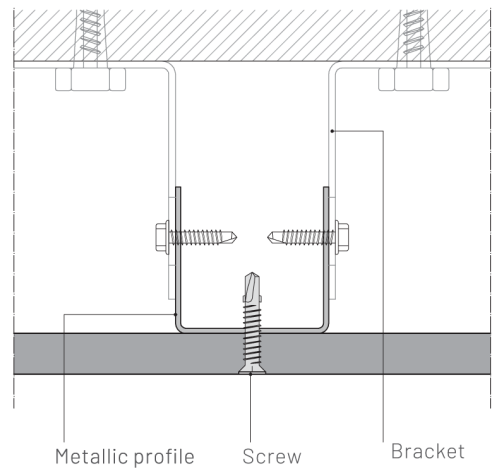

Detail E (wood structure)
Joints between boards

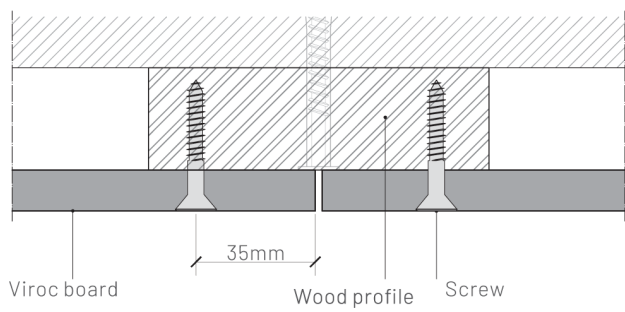

Detail F (wood structure)
Board central zone

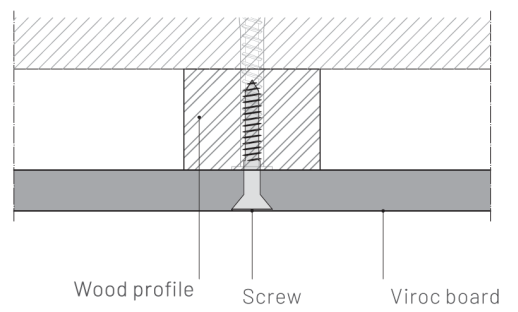

Internal Wall Cladding (continued)

Detail of the joint

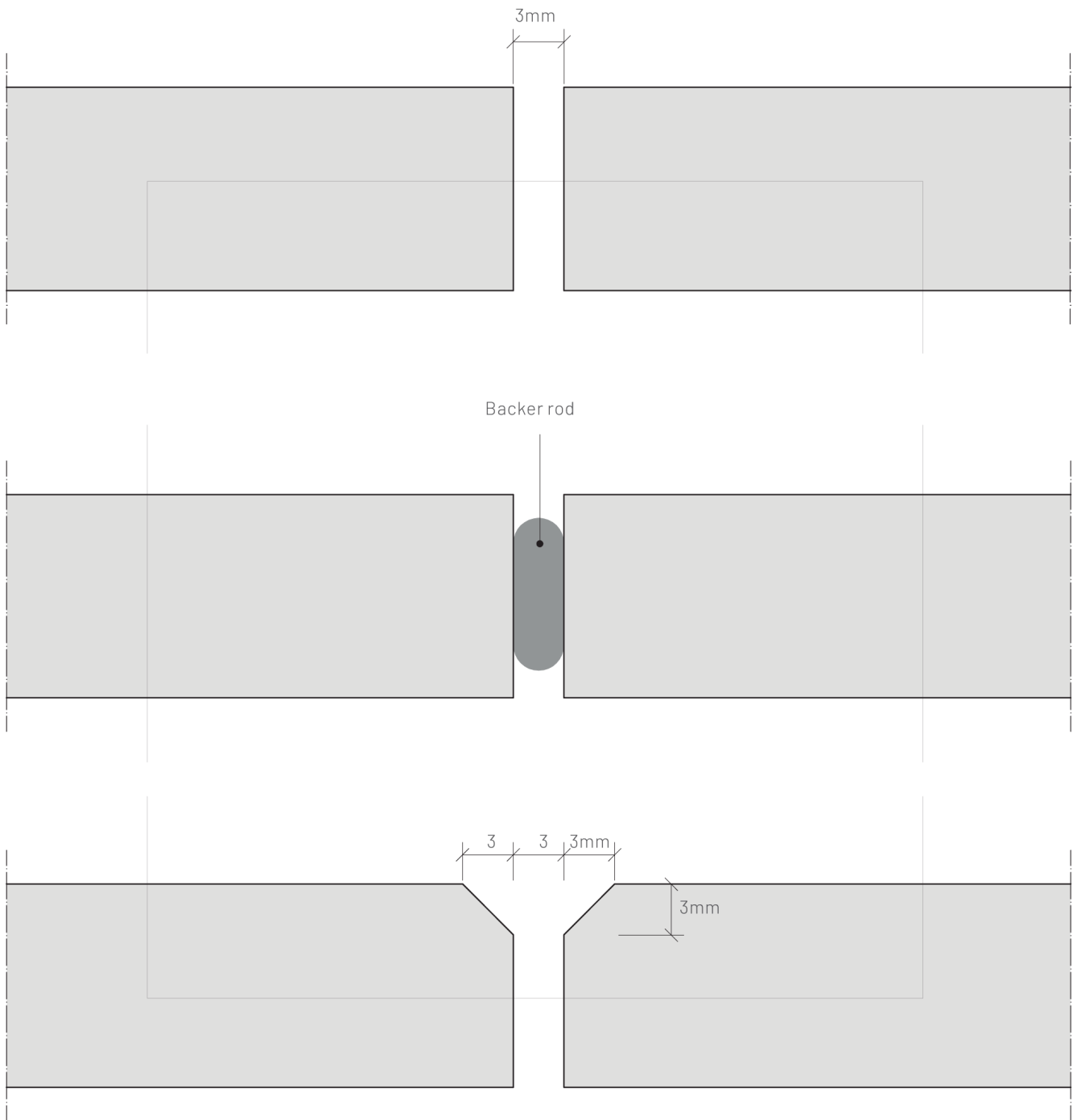

Internal Wall Cladding (continued)

Vertical sections

Steel structure

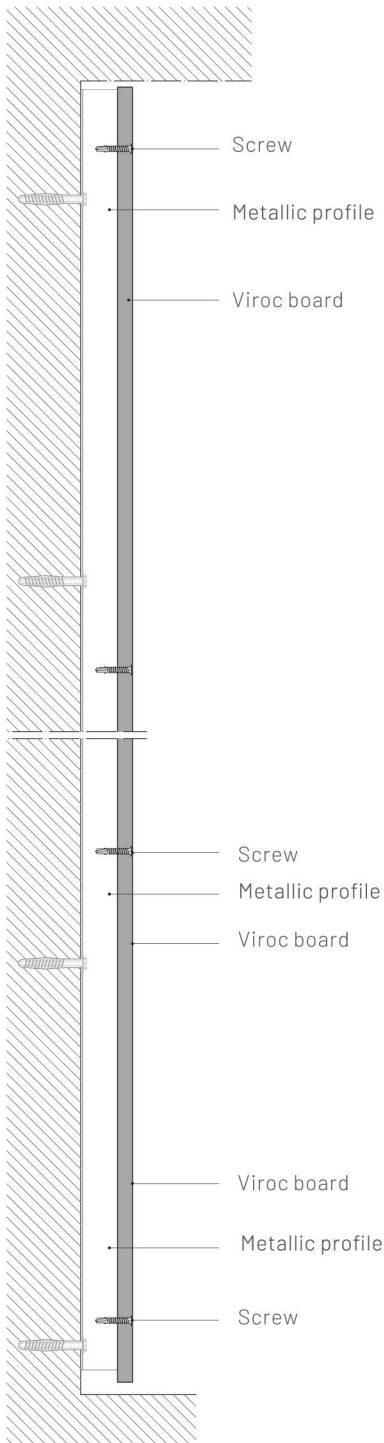

Steel structure (alternative)

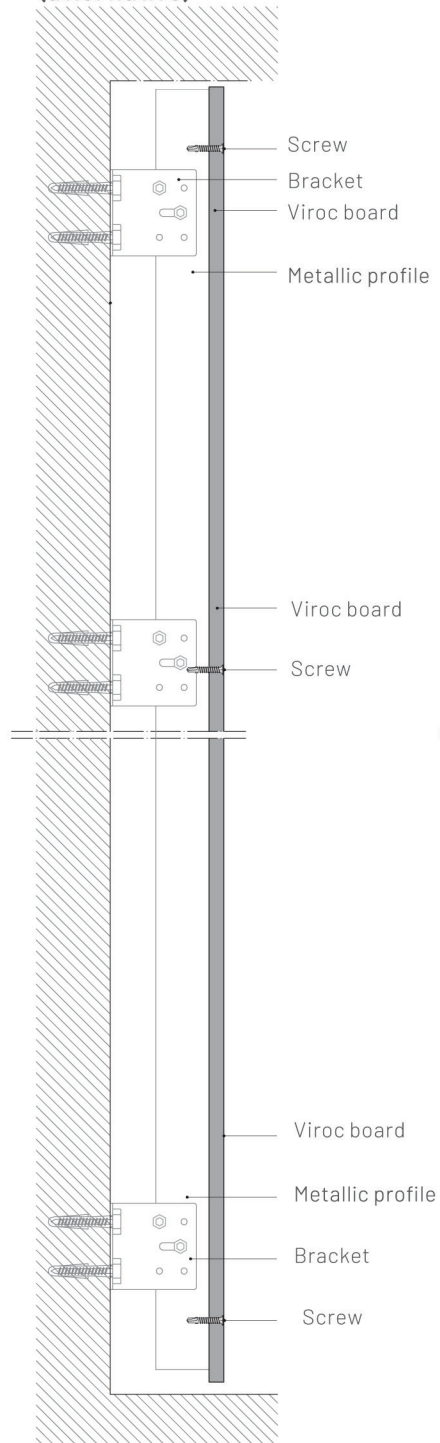

Wood structure

