



Product Showcase

French Oak Flooring



The luxurious
signature in premium
architectural spaces

Modinex's passion is to turn your creative vision into reality. Through collaboration with architects & designers, we thrive by creating spaces that not only enrich your lives but positively impact the world around us.

Our range of bespoke timbers and architectural timbers is the provision required for all you need to enhance & elevate your space – let us be your design innovation partners.



How to specify

Download REVIT files, installation instructions, product care and technical information at modinex.com.au



Plank

Thickness: 15mm & 21mm

Width: 220mm

Length: 2200mm

- In 15mm thickness, the colour Fossil Grey is a 240mm x 1900mm plank and Mink is a 220mm x 1900mm plank
- Other widths and lengths are available on request

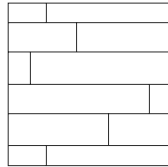

Wear Layer

Our 15mm profiles have a 4mm wear layer, and 21mm thick profiles have a 6mm thick wear layer.

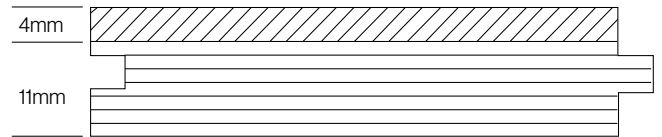

Herringbone

Thickness: 15mm

Width: 120mm

Length: 600mm

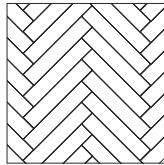

Coating

Manufactured with 8 coats of Treffert Sapphire matt for heavy duty use. Treffert Sapphire is the best performing scratch resistant coating system for flooring in the market today. This special coating system is ideally suited for surfaces in demanding environments or needing long-time guarantees.

- Non-toxic
- Two-component water based poly top coat
- Excellent wear resistance

Chevron

Thickness: 15mm

Special order

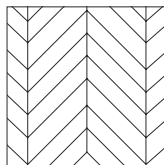

Grading

All finishes are standard in classic grade. If a clearer grade timber with less knots or feature is required, Signature grade is available with a 12-week lead time.

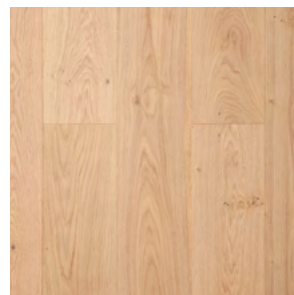

Signature

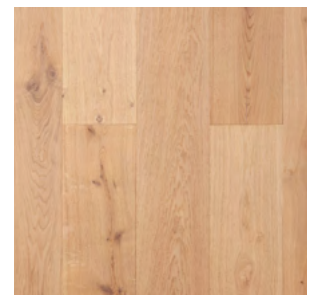

Classic



Stair Nosing

Stair Nosing 01

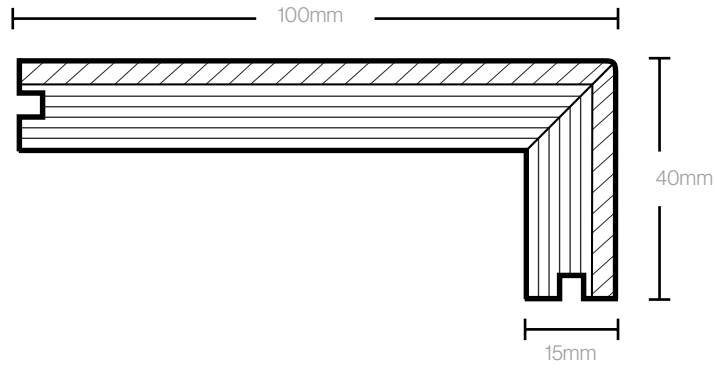

Stair Nosing 03

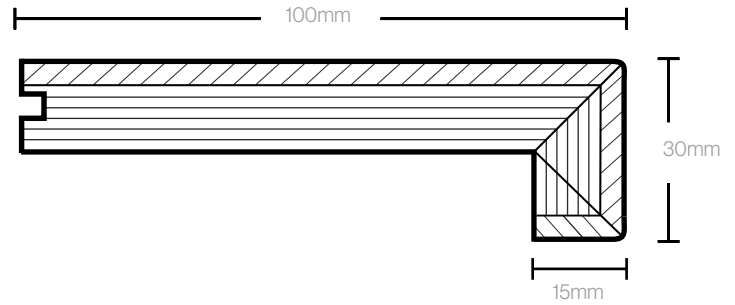

Colours



French Oak Raw



Sand Oak



Almond



Dusk



Moonshine

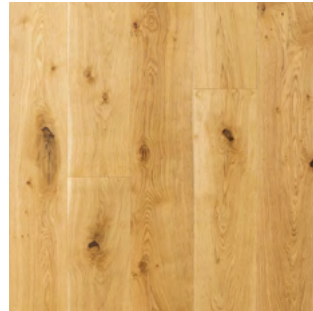

Golden Haze

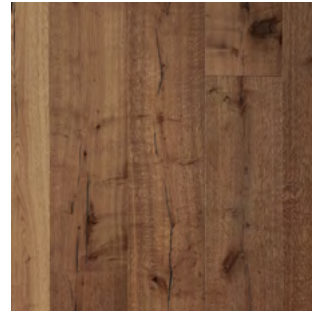

Desert Sand

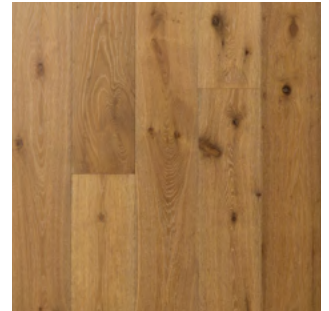

Frosted Oak

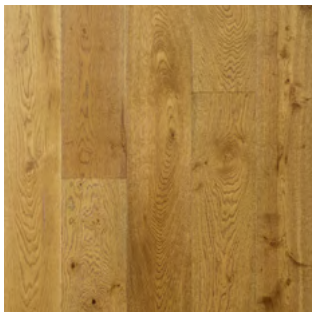

Woodland

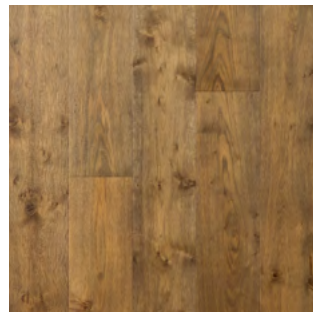

Burnished Ash

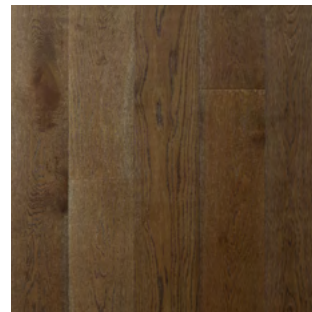

Dark Moonstone



Mocha

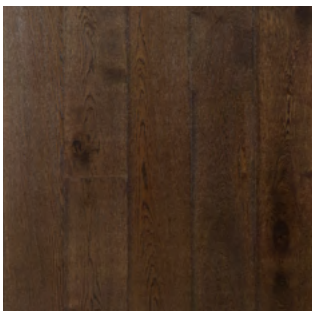

Burnt Umber

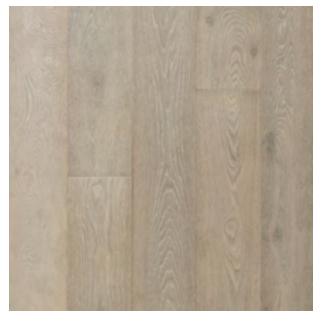

Wharf Grey

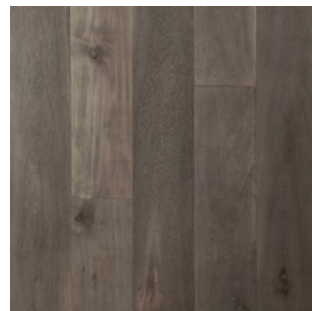

Fossil Grey



Mink

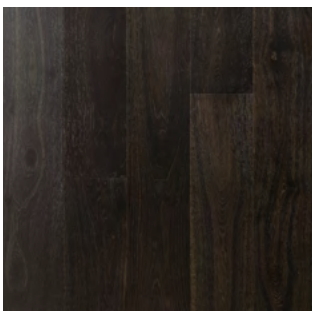

Midnight



Create stunning wow factor
with flexibility of style, texture,
colour, shape and species.

Talk with our design team today about how to maximise the grandeur of your space. Our extensive product range puts a wealth of inspiration at your fingertips. We can even collaborate with you to innovate custom solutions, specifically designed to bring your vision to life and elevate your space with exclusive designer appeal.

 **Modinex**

Let us help you specify your next project

Contact P—1800 156 455 E—hello@modinex.com.au

Learn more

Inspiration and product downloads
available at [modinex.com.au](https://www.modinex.com.au)

